



THE FORMWORK

NOE[®]stairs

Dated: 09.2014

Operating instructions

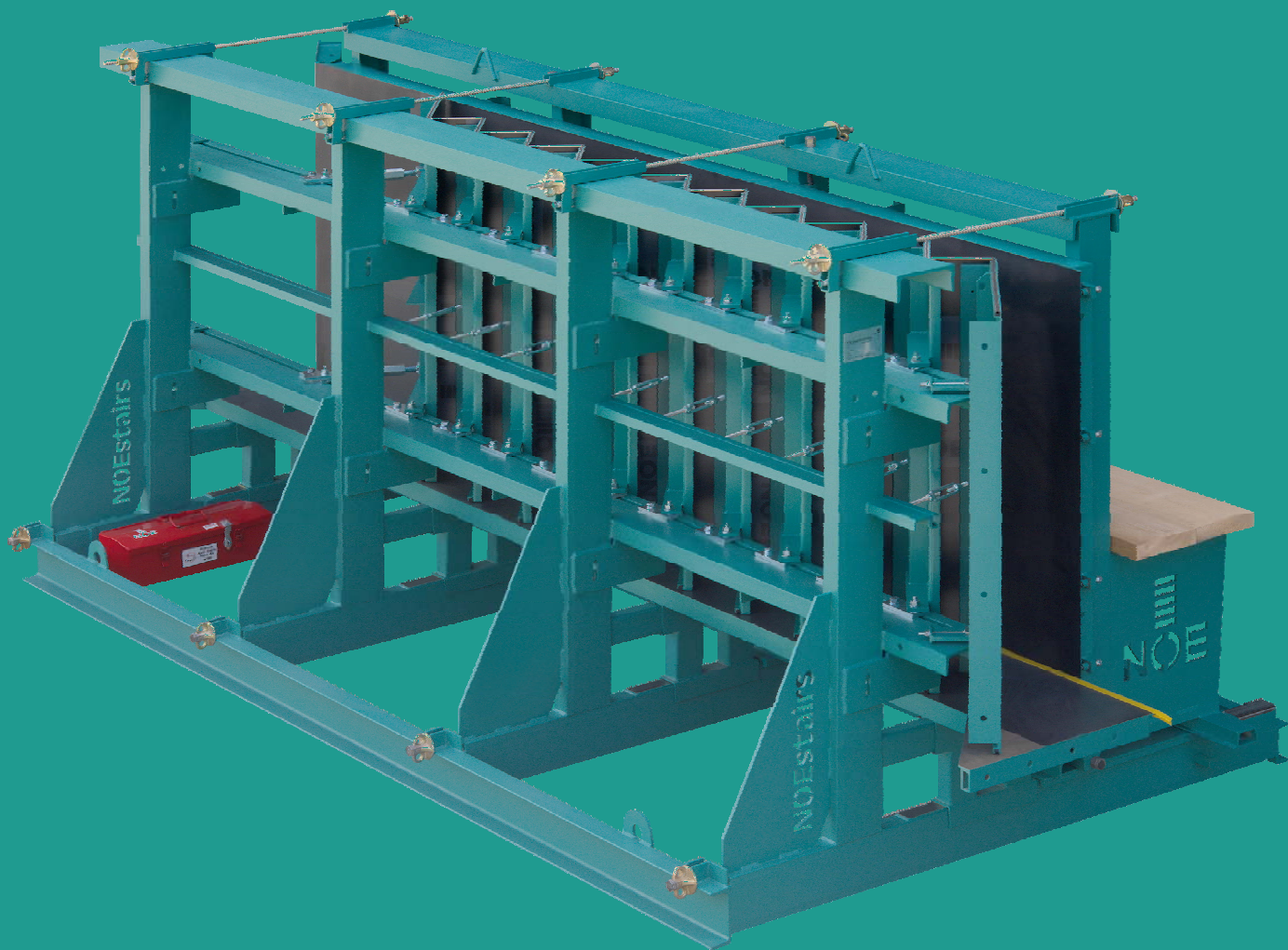

1.	Operating instructions	3
1.1	Product features	3
1.2	Technical data	6
1.3	Safety advice	7
1.4	Proper use	7
1.5	Component assemblies	8
1.6	Use of stair formwork	9
1.7	Maintenance and care	18
1.8	Transport	18
2.	Attaching platforms	20
3.	Setting dimension for stair formwork	22



Read and observe the operating instructions



Keep the operating instructions for future use on site in an easily accessible place so that they can be viewed at any time.

Key:



Attention!



Note



Visual inspection

1. Operating instructions



1.1 Product features

Description	
Part No.	
Serial No.	
Self-weight	kg
Year of manufacture	

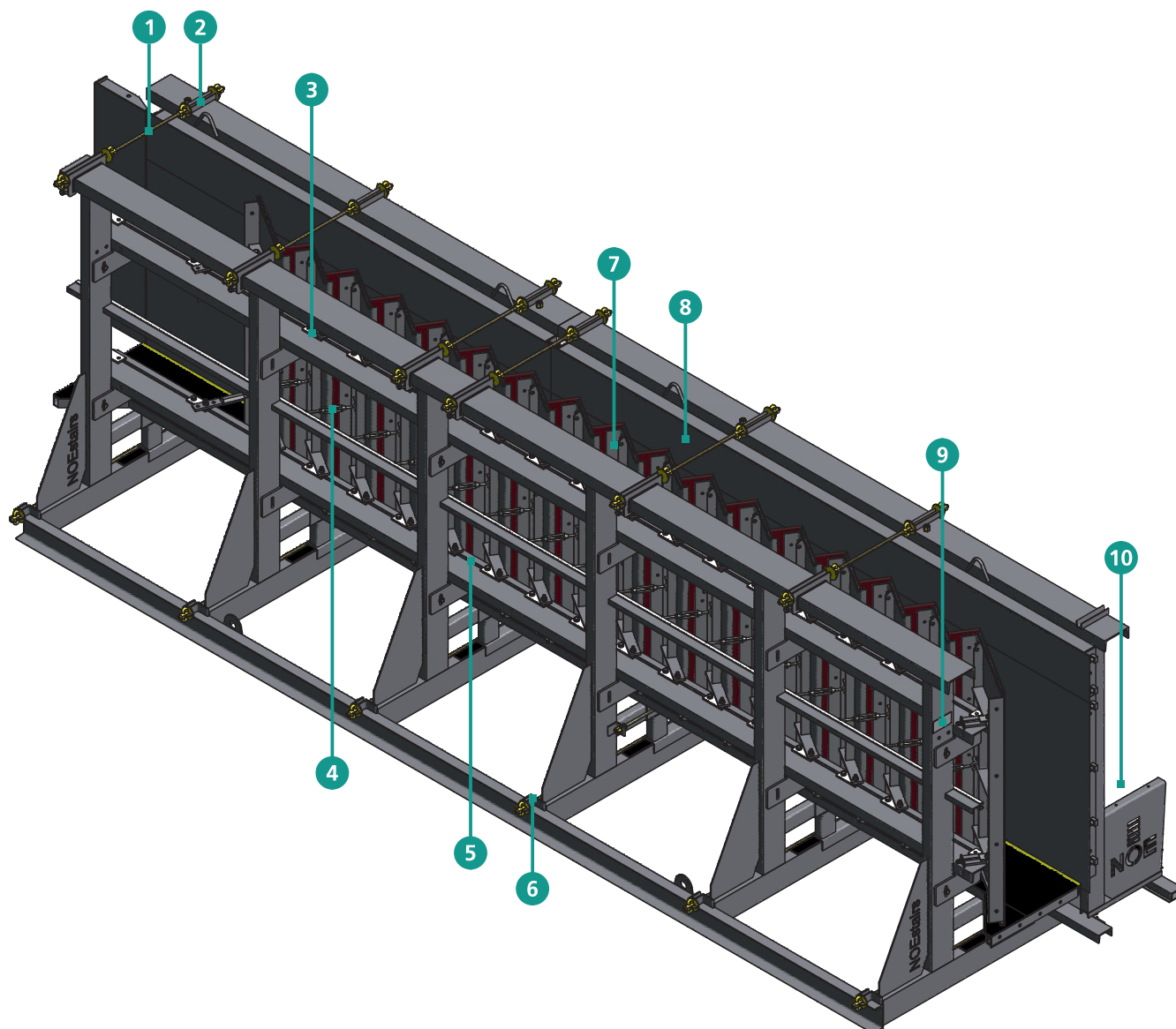

Figure 1.1

1. Tie rod
2. Sliding tie rod fixing
3. Adjustment plate with bolt
4. Turnbuckle for step plate
5. Adjuster assembly
6. Back wall tie
7. Stair plates
8. Attachment piece, 300 mm high (special option)
9. Type plate
10. Boards provided by customer on site
11. Back wall height adjustment
12. Gear drive for moving the back wall
13. Clamping wedge only for longitudinal movement or for lifting the back wall
14. Bottom adjustment D
15. Adjustment screw for bottom

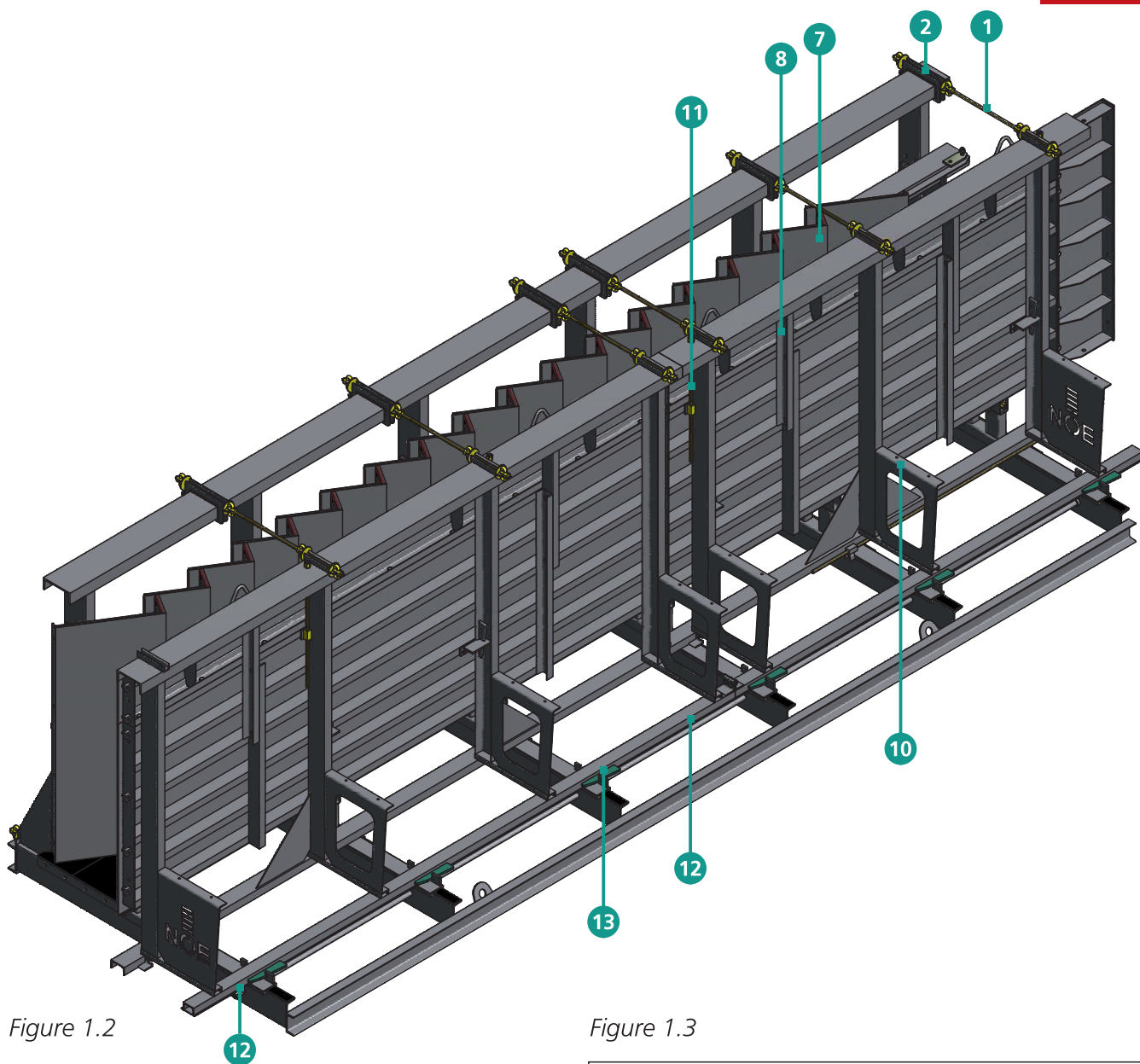
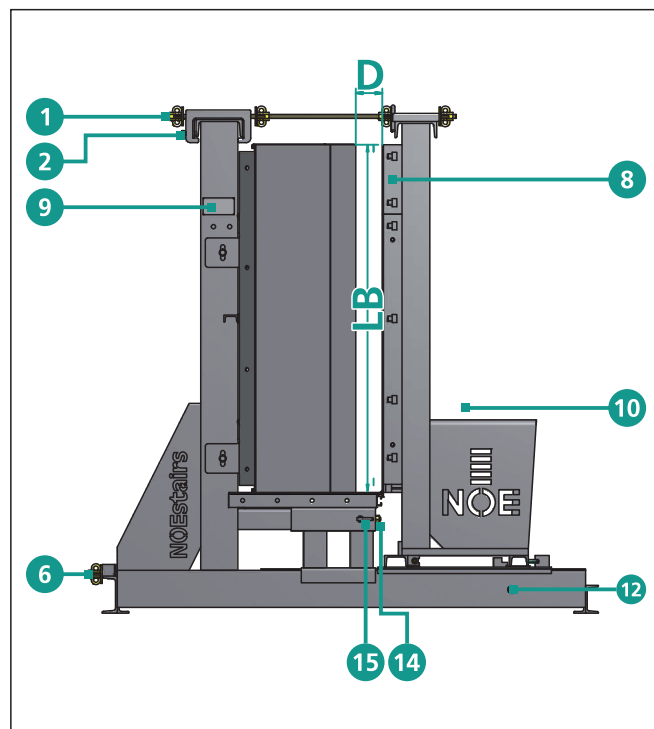

Figure 1.2

- A = Going
- D = Stair slab thickness
- LB = Stair width
- S = Rise
- Z = Setting dimension from tables on pages 22 and 23

Figure 1.3



1.2 Technical data

Stair width	LB	950–1250 mm or 1200–1500 mm (900–1500 mm with 300 mm high attachment piece)
Stair slab thickness	D	100–200 mm
Rise	S	150–200 mm
Going	A	220–320 mm

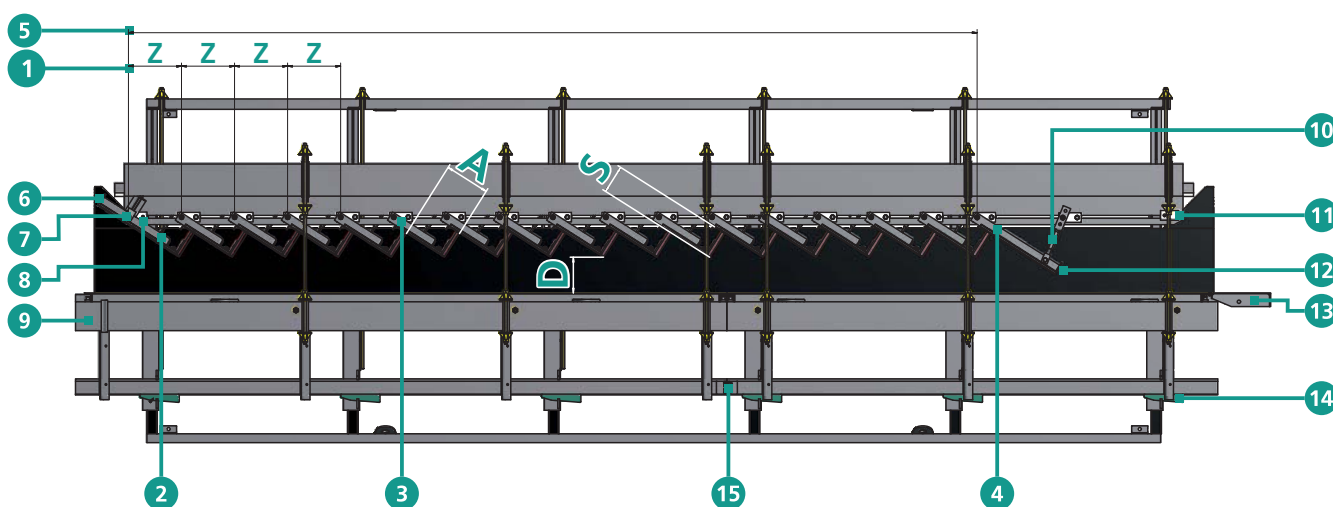

Figure 2

If the bottom step rise is greater, the start step can be infinitely adjusted to be max. 100 mm higher than the normal rise.

The formwork panel can be used for anticlockwise or clockwise stairs by mirroring the stair plates.

1. Z x number of stairs
 2. Start step
 3. Standard steps
 4. End step
 5. Check dimension
 6. Landing connection
 7. Adjustment of start stair with deviating rise
 8. Fixed point clockwise stairs
 9. Longitudinally movable back wall
 10. Positioner for end stair
 11. Fixed point anticlockwise stairs
 12. Landing connection
 13. Connection hinge
 14. Wedge for back frame
 15. Separation point of back wall (special option)
- A = Going
D = Stair slab thickness
LB = Stair width
S = Rise
Z = Setting dimension from tables
on pages 22 and 23

1.3 Safety advice

The requirements of BG Bau must be noted and complied with.

1. The operating instructions must be observed when using NOEstairs stair formwork.
2. The accident prevention rules and regulations applicable for the place of use must be observed.
3. The contractor must ensure that the operating instructions supplied by NOE are kept readily accessible at the place of use.
4. If the contractor's own employees are responsible for the use of NOEstairs formwork, they must all be familiar with the tasks involved.
5. Trained personnel only shall work with NOEstairs stair formwork.
6. The responsibilities of the personnel for installation, bringing into use, operation, setting up, servicing and repair must be clearly defined.
7. NOEstairs stair formwork must be used in such a way that no-one is placed in any danger.
8. Personnel must never stand under suspended loads.
9. During the concreting process, no person must be allowed to stand between the back wall and stair plates.
10. All safety measures and devices must be properly attached and capable of functioning before each use of NOEstairs stair formwork.
11. All safety and hazard information on the equipment must be kept in legible condition.
12. The equipment must be checked for visible external damage and the safety devices checked for proper functioning at least once per shift.

1.4 Proper use

These operating instructions contain information about the handling and use in accordance with the regulations of NOEstairs stair formwork.

NOEstairs stair formwork is used for the production of straight precast concrete stair units.



Attention:
Any other use, or use beyond this purpose, shall be considered improper use. Proper use also includes the observation of all advice in the operating instructions and the performance of the necessary inspections and maintenance work.

Furthermore, the latest version of the relevant national safety regulations must be complied with (e.g. in Germany, the accident prevention regulation).



All replacement parts must be NOE original parts.

To ensure the formwork functions perfectly, it must be set level longitudinally and transversely. The use of dowels or concrete anchors is recommended to prevent lifting.

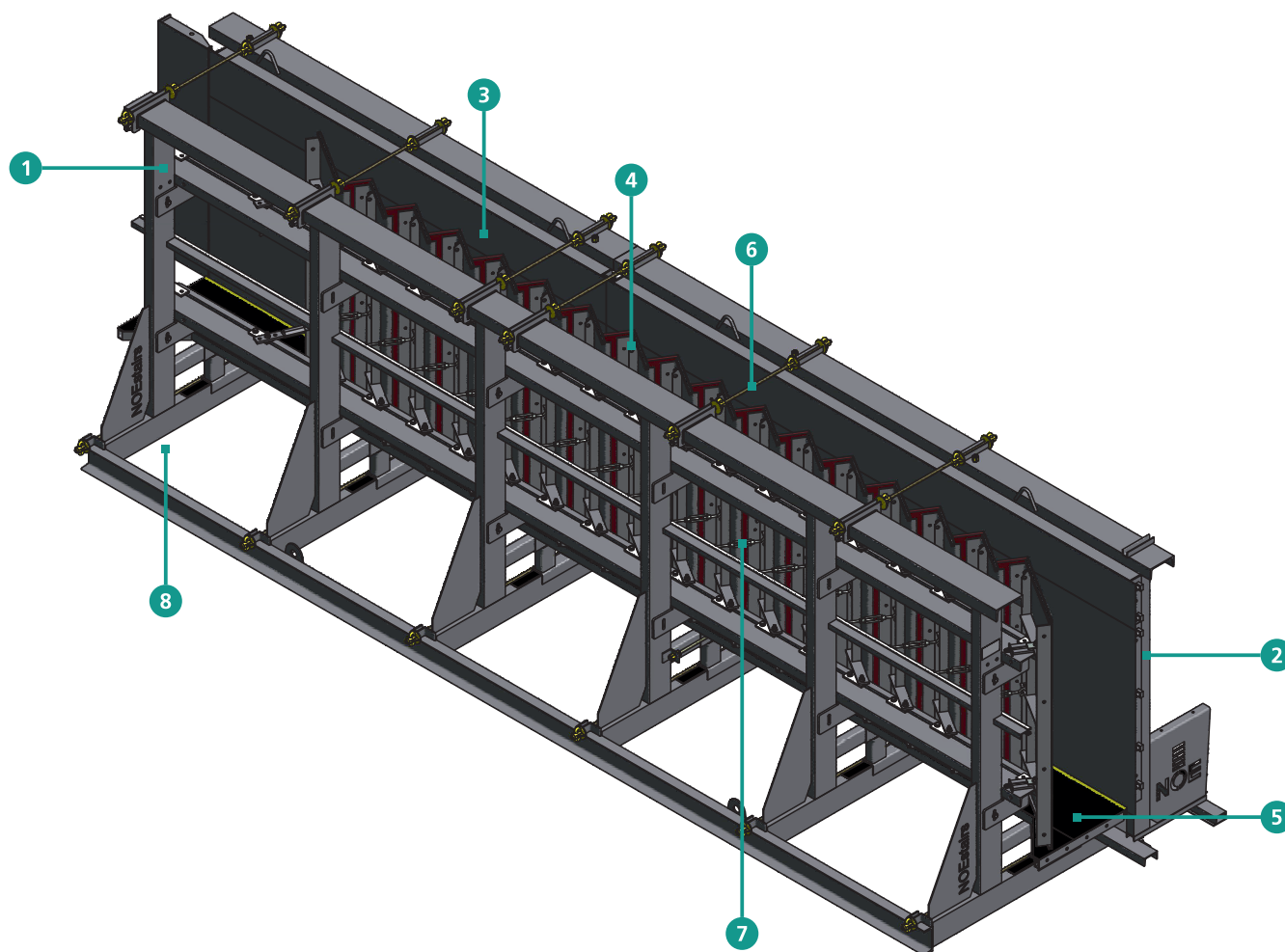

Figure 3

1.5 Component assemblies

NOEstairs stair formwork can be divided into the following component assemblies (Figure 3):

1. Basic frame
2. Back wall frame
3. Back wall
4. Stair plates
5. Bottom
6. Top tie bar
7. Turnbuckle for stair plates
8. Toolkit

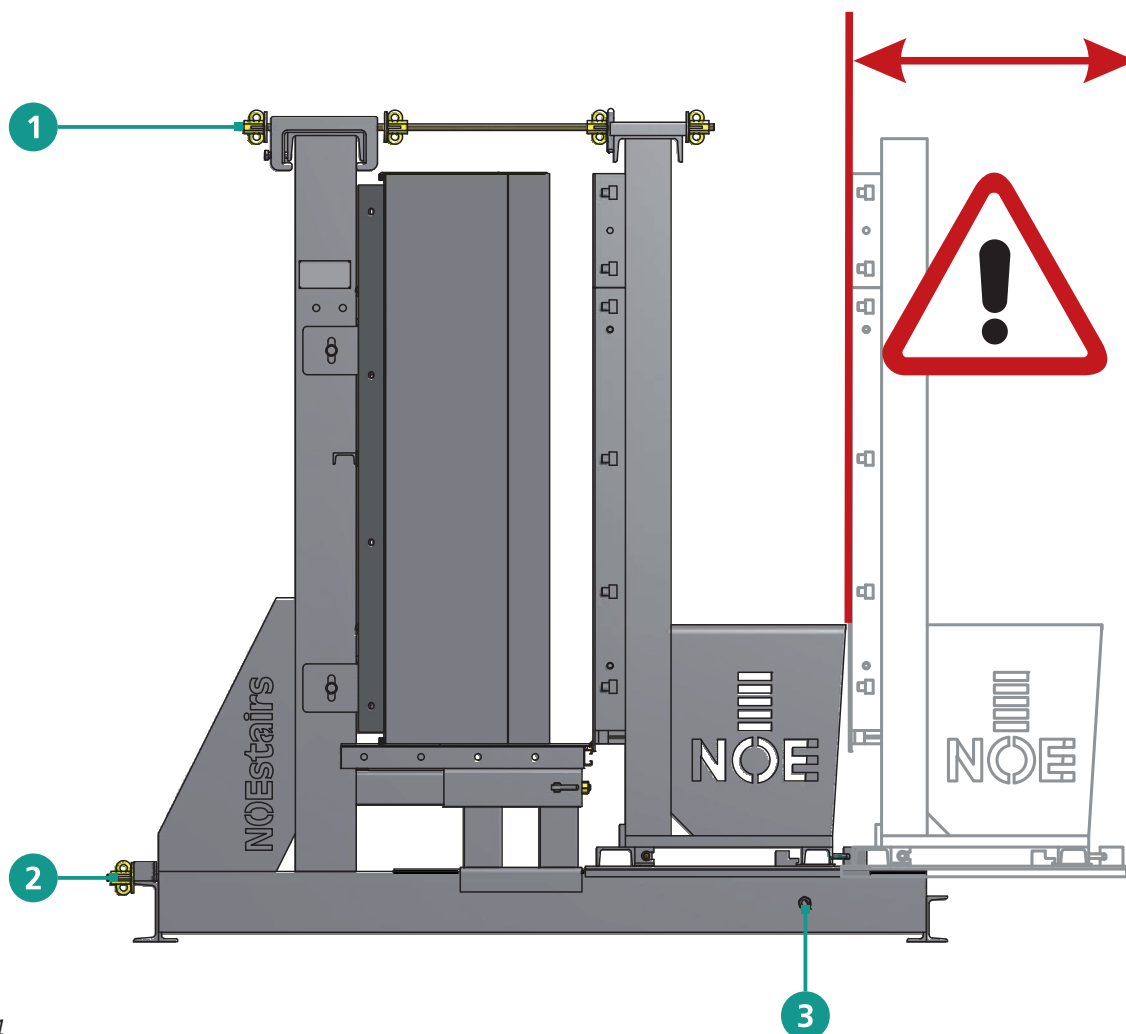

Figure 4

1.6 Using the stair formwork

1.6.1 Moving the back wall

Release and disengage the top ❶ and bottom ❷ tie rods.

Move the back wall backwards as far as it will go with the gear drive ❸ using a ratchet wrench (size = 30).



Attention:
The movement path must be clear.

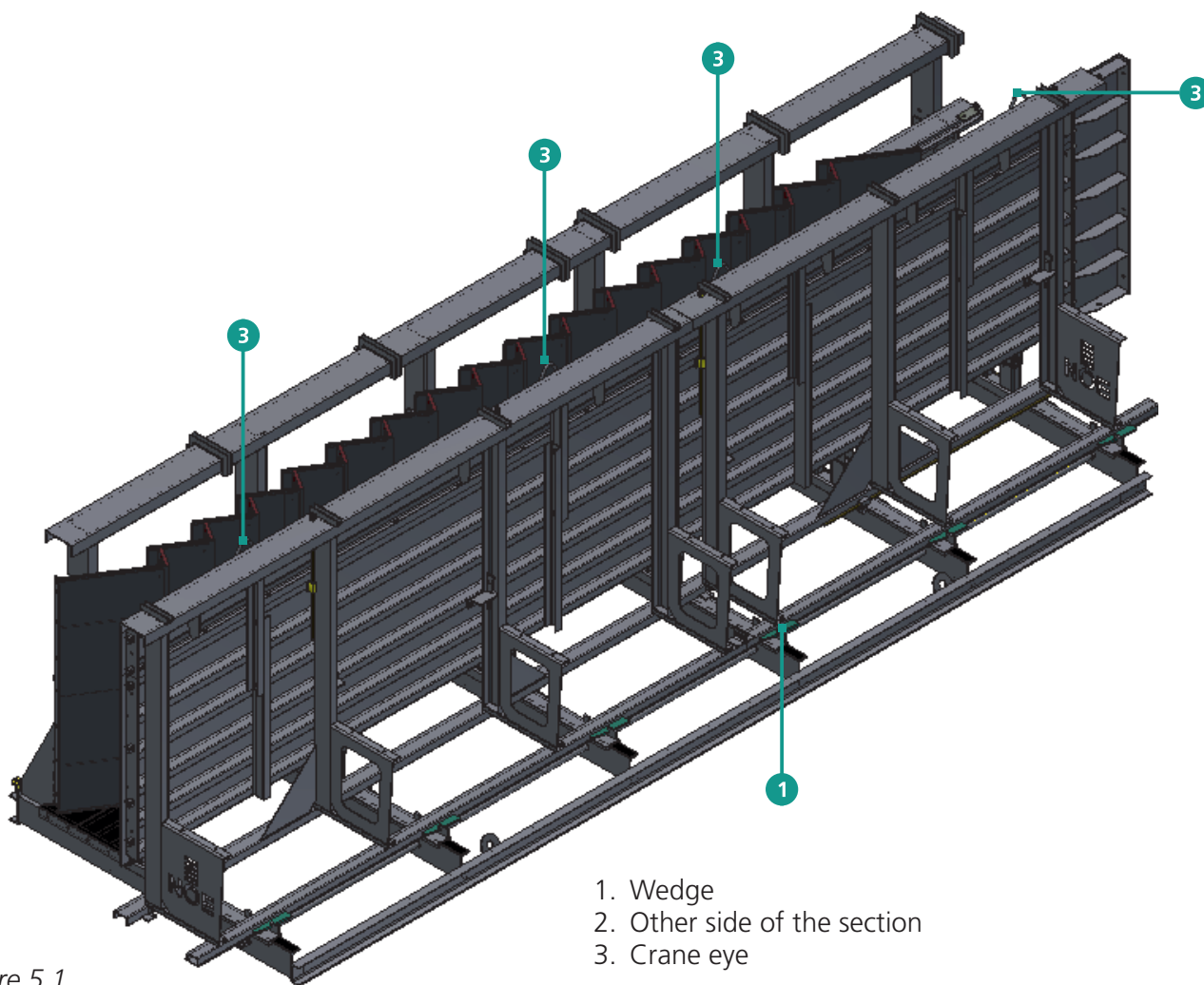

1. Wedge
2. Other side of the section
3. Crane eye

Figure 5.1

1.6.2 Lifting the back wall

Secure the back wall by suspending it from the crane eyes ③ provided.

Release the wedges ① on the fixings and by driving them in on the other side of the section ② push the back wall out of the overturning restraint (see Figure 5.2).

Suspend the back wall from the crane eyes provided and lift it off.



Attention:
Secure the back wall against overturning when placing it down!
Crushing hazard!

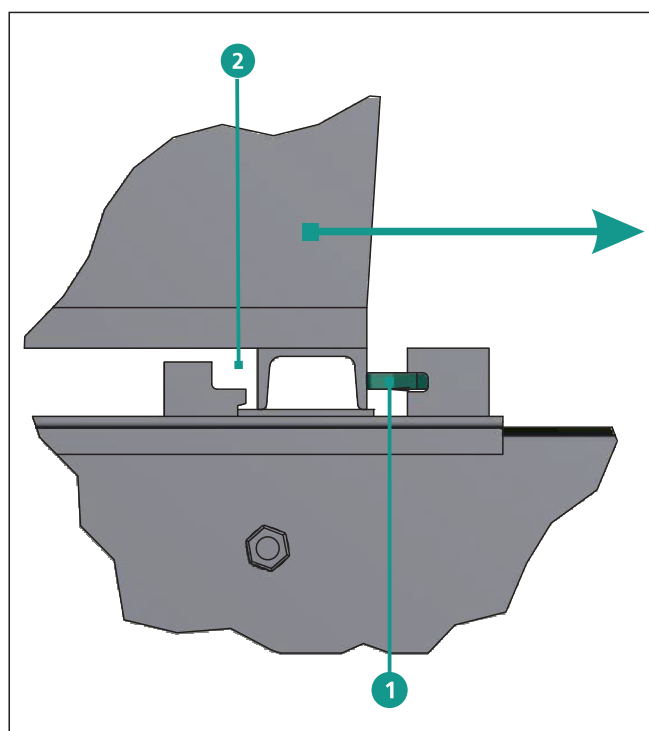

Figure 5.2

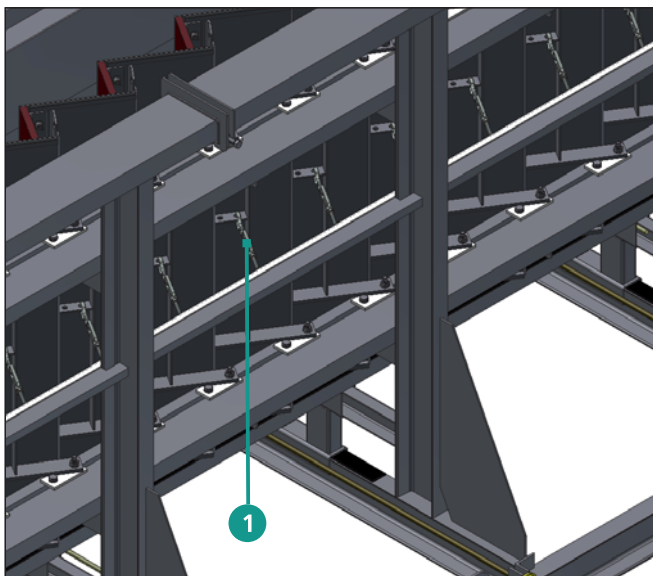

Figure 6.1

1.6.3 Stair setting (dimension Z)

The setting dimension (distance between the bearing bolts of the stair plates) depends on the ratio of the going to the rise. This can be taken from the tables on pages 22 and 23 Setting dimensions NOEstairs stair formwork.

First slacken the turnbuckles of the stair plates and unhook them from the halfen rails (see Figures 6.1 and 6.2).



Figure 6.2

1. Turnbuckle
2. Perforated rail
3. Halfen rail

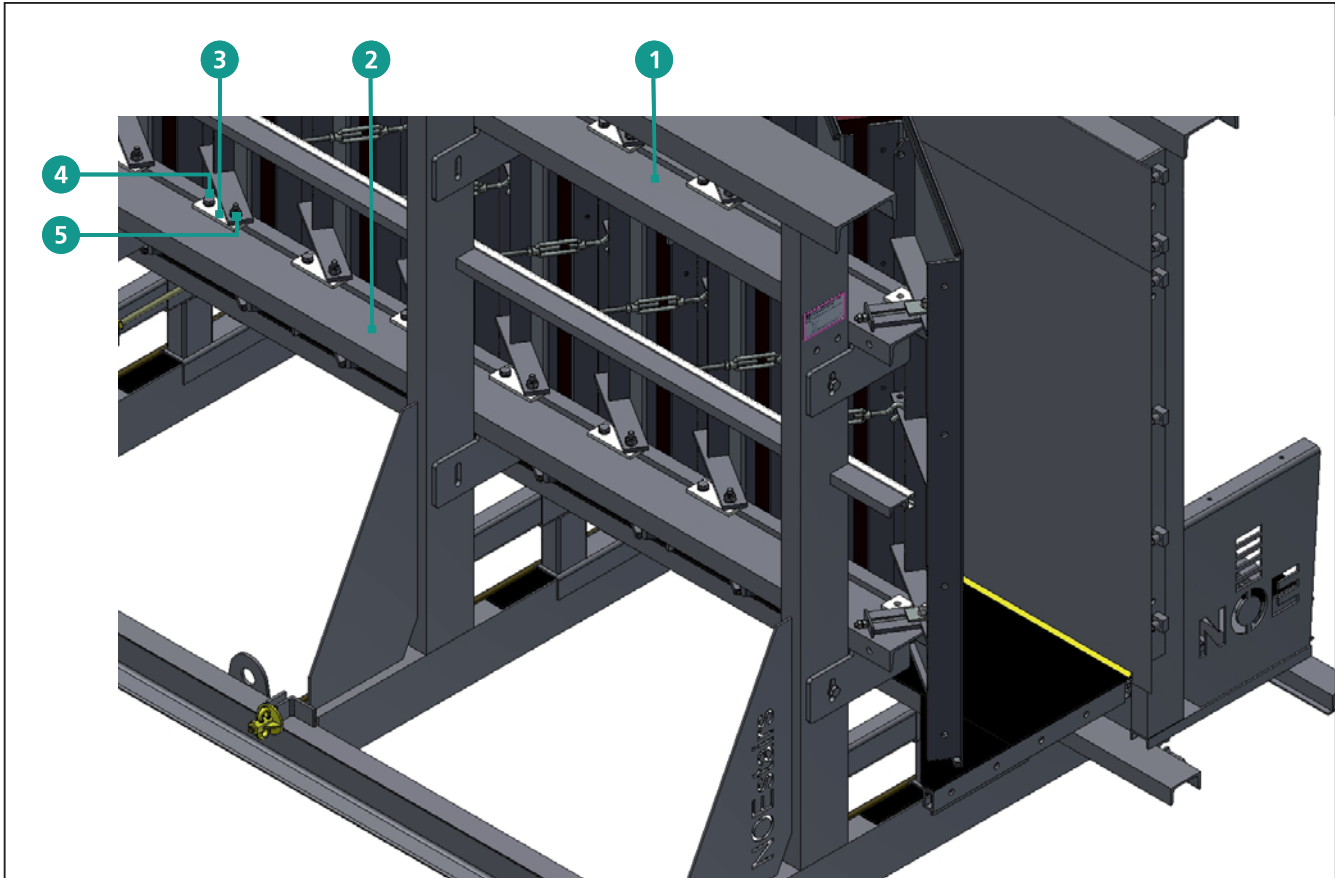

Figure 7.1

- | | |
|--------------------------|---------------------------|
| 1. Top adjuster assembly | 3. Bolt plate |
| 2. Bottom adjuster | 4. Clamping bolt assembly |
| | 5. Bearing bolt |

Then release the hexagonal nuts on the bearing bolts and the clamping bolts on the bolt plates for the bottom and top adjuster assembly (see Figures 7.1 and 7.2).

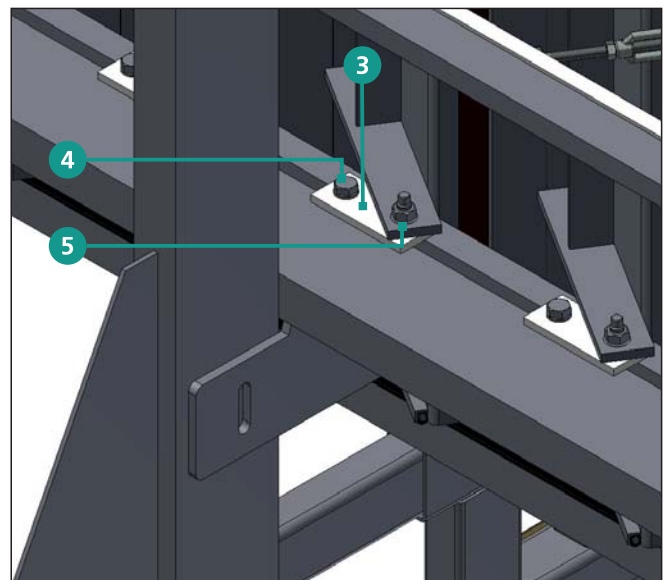

Figure 7.2

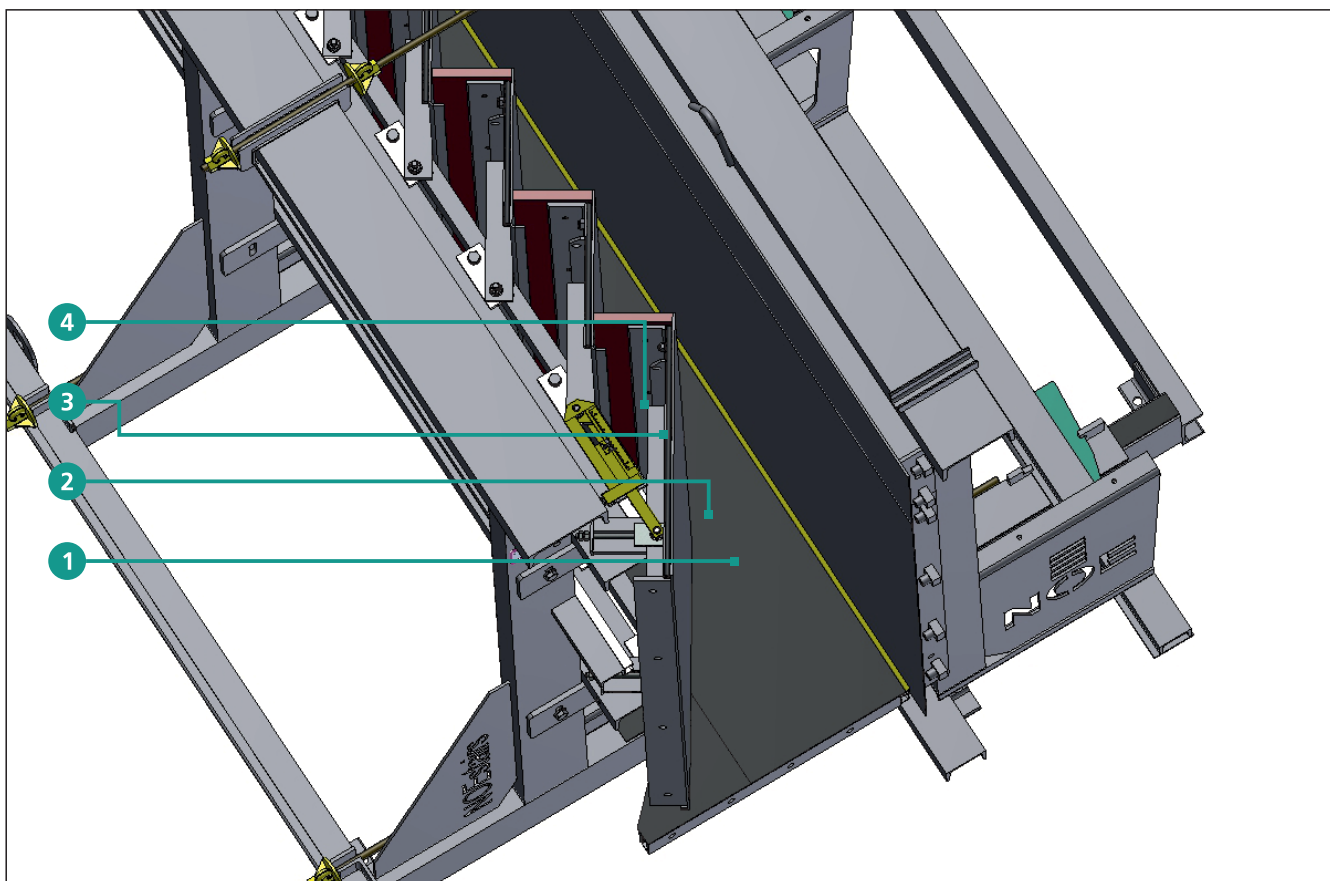

Figure 8.1

- 1. Fixed point clockwise or anticlockwise stairs
- 2. Setting gauge
- 3. Bearing bolts
- 4. Clamping bolt

After this, with the setting gauge and the setting dimension (Z) derived earlier from the tables on pages 22 and 23, bring the bolt plates one after the other into the correct position and tighten the clamping bolt. To do this, the setting gauge is placed on the ends of the bearing bolts (Figures 8.1 and 8.2).

Start at the start stair, the bolt plates of which were aligned and fixed in place on each of the adjuster assemblies at the factory.

When all the stair plates are correctly set and the riser boards inserted, the end stair must be set using the turnbuckles in such a way that its going and those of the following stairs run exactly parallel to one another (Figure 9.2). The riser board of the next stair must rest on the end step.

The setting from the setting dimension from table (Z) and rise (S) automatically gives the going (A).

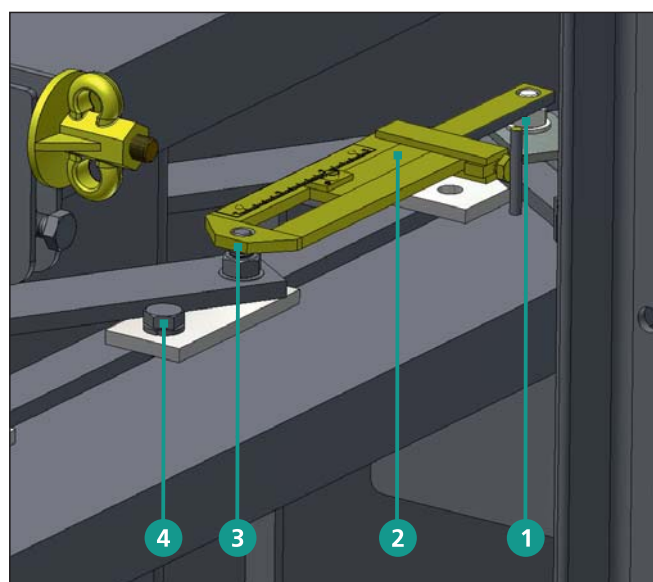

Figure 8.2

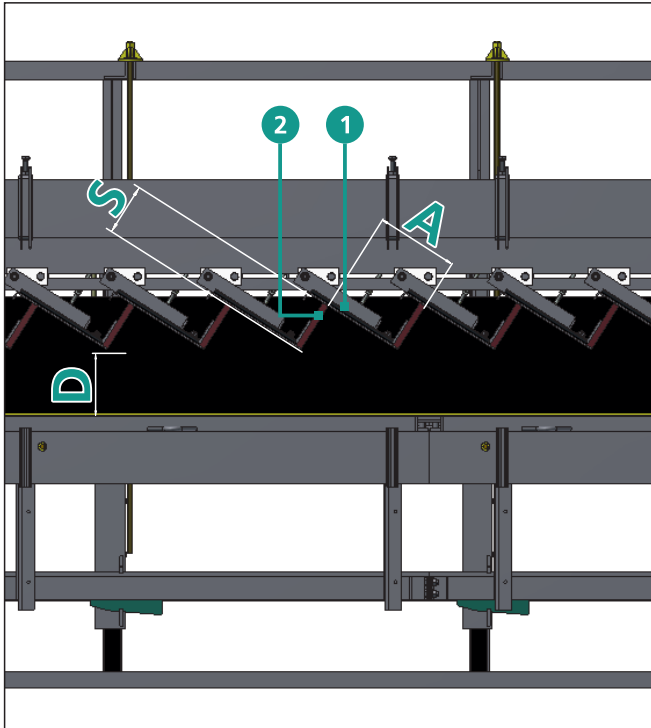

Figure 9.1

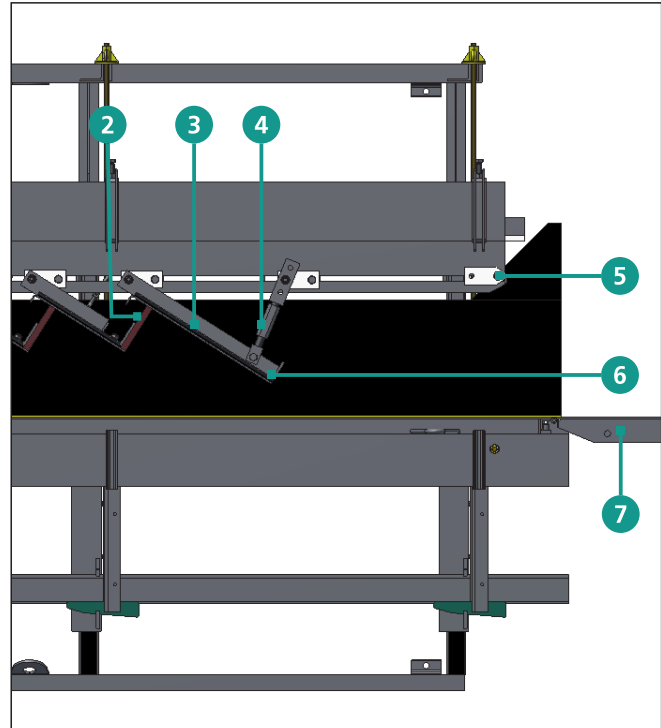

Figure 9.2

1.6.4 Setting the rise (S)

Assuming 21 mm thick riser boards, rise less 5 mm stair plate thickness.

Example

Rise (S)	178 mm
Less stair plate thickness	5 mm
Height of going board	173 mm

Fasten the riser board to the step angle section with wood screws (Figure 9.1).

The stair plates are then clamped against the previous stair plate one after the other by hand (no tool) with the turnbuckle (Figure 9.3).

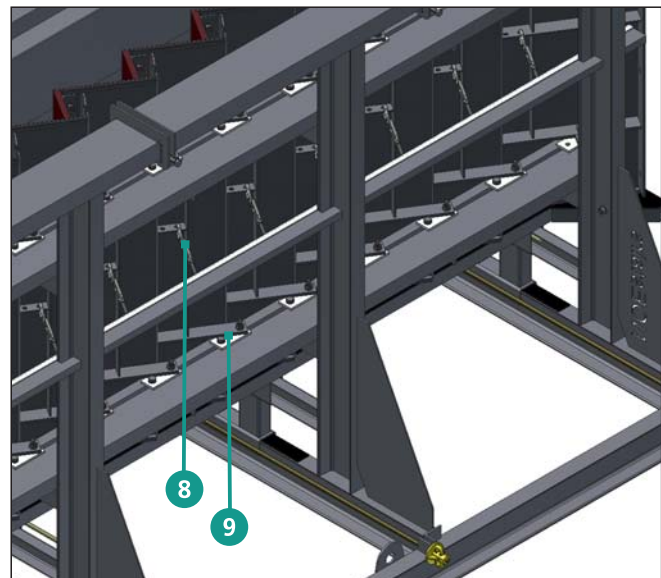

Figure 9.3

1. Standard stair
2. Riser board
Fastened from rear with wood screws
3. End step
4. Turnbuckle
5. Fixed point anticlockwise stairs
6. Landing connection
7. Connection hinge
8. Turnbuckle
9. Bearing bolts

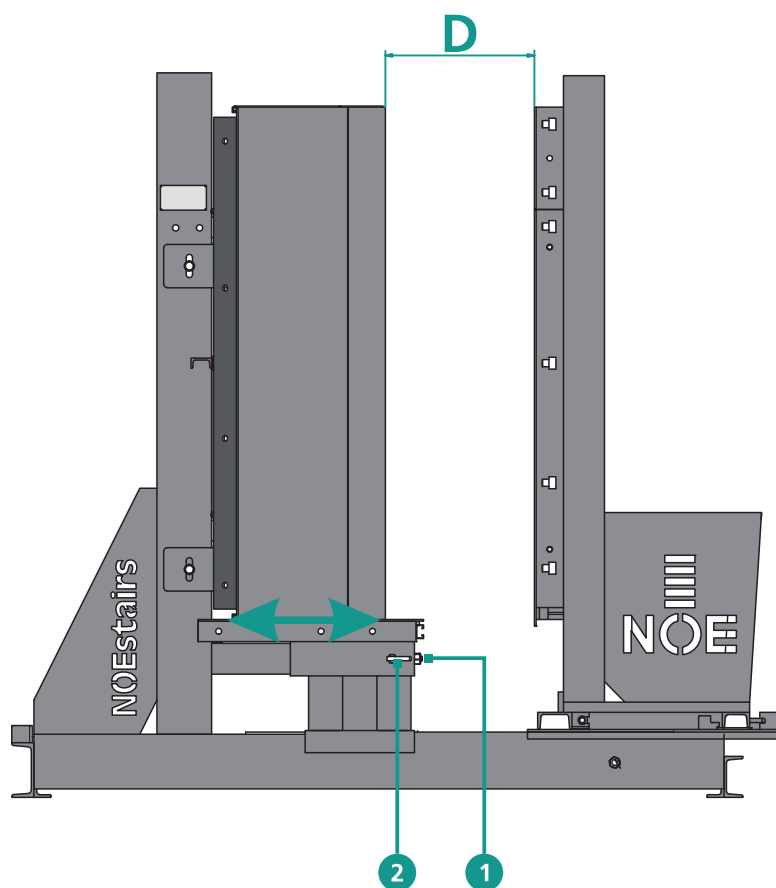

Figure 10.1

1.6.5 Setting the bottom

The bottom of the formwork can be moved transversely with two spindles and clamped with the two wing head bolts to set the stair slab thickness (D) (Figure 10).

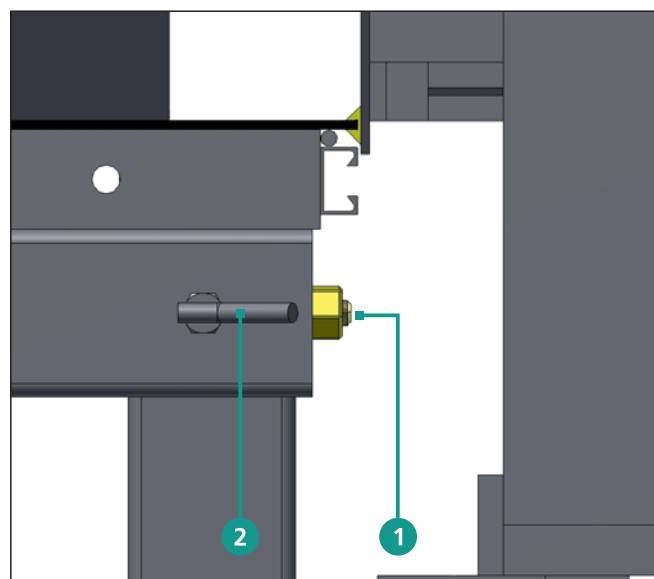

Figure 10.2

1. Bottom setting
2. Wing head bolts bottom

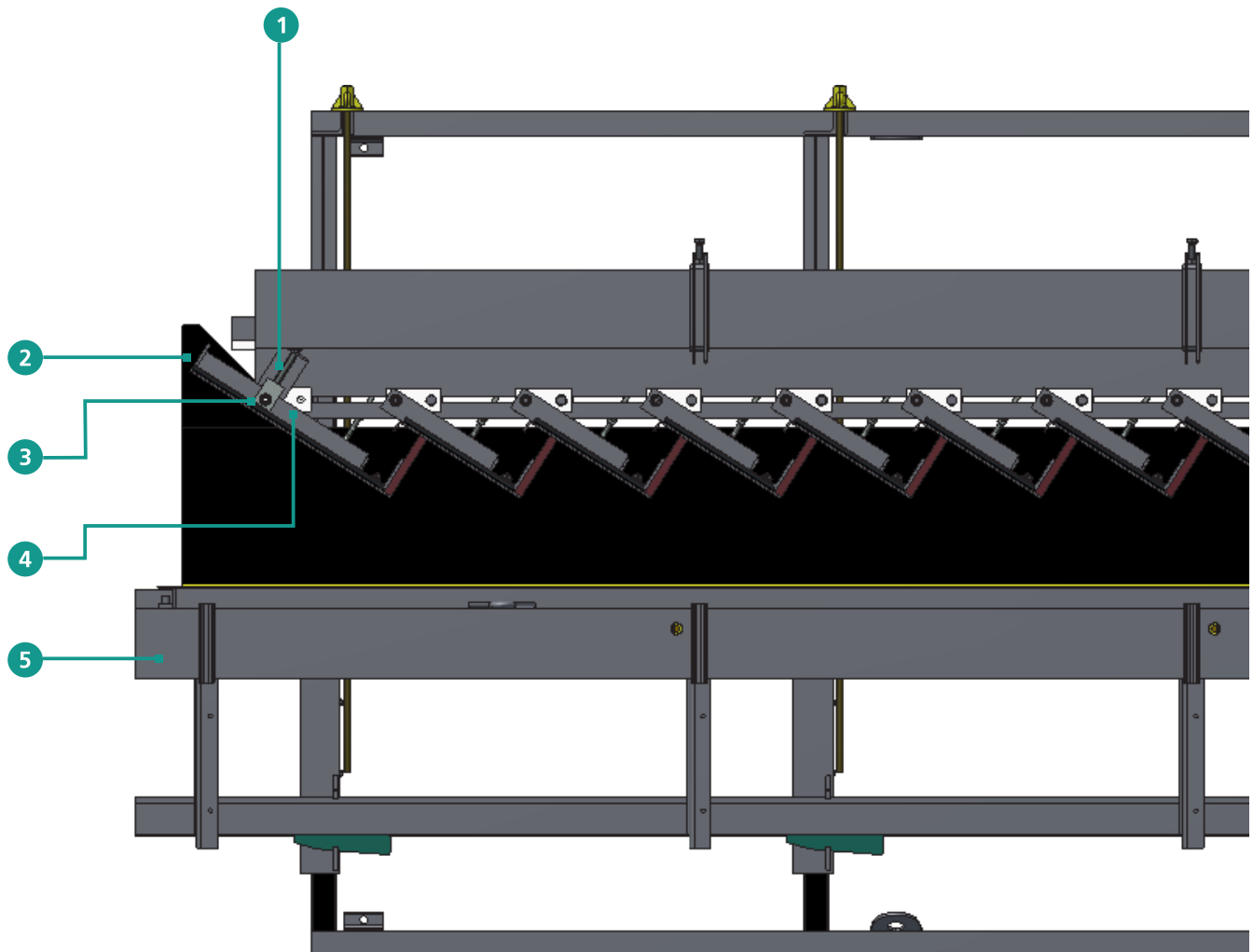



Figure 12

1. Adjustment of the start stair rise height by up to 100 mm
2. Landing connection
3. Start stair
4. Fixed point clockwise stairs
5. Longitudinally movable back wall

1.6.7 Setting the start stair

The start stair rise setting can be varied by up to 100 mm using the elongated hole and the adjuster bolt.

After setting in the desired position, tighten the hexagonal nuts on the two bearing bolts and secure with the adjuster bolt.

 **The riser board must be modified to suit the changes rise dimension.**

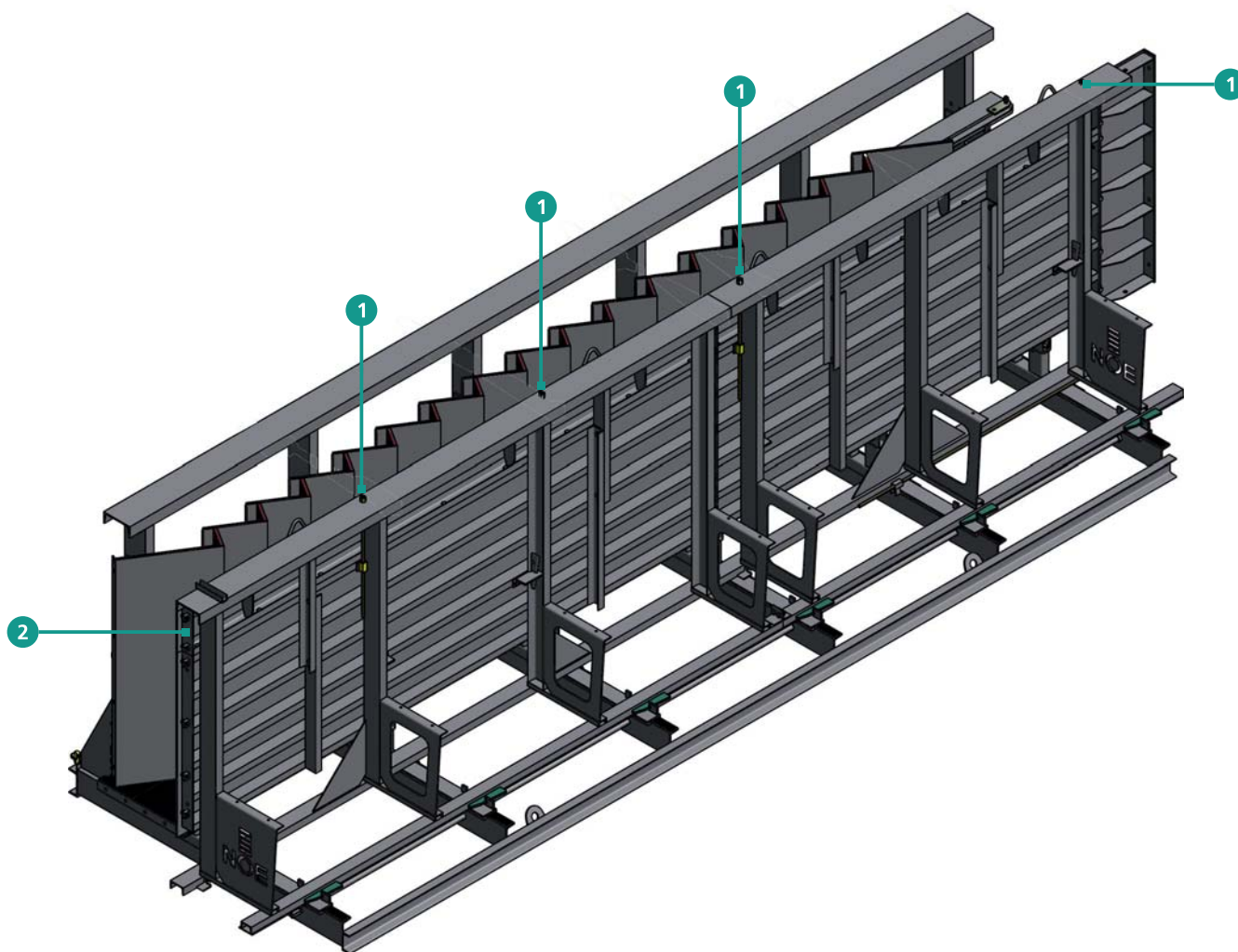

Figure 11

1. Back wall height adjustment
2. Attachment piece, 300 mm high (on request)

1.6.6 Setting of the back wall

The back wall can be moved up and down on spindles to set the stair width (LB) (Figure 11).

Narrower stairs can be manufactured by inserting a timber bottom.

Likewise the LB can be increased or decreased by using an attachment piece (300 mm high) (on request). The vertical separation point in the back wall offers the possibility of producing 2 stairs (1 anticlockwise, 1 clockwise) at the same time (on request).

1.6.8 Moving and insertion of the back wall

The back wall is handled in the reverse order to that shown on pages 9 and 10, items 1.6.1 and 1.6.2 . Reinsert and tighten the top and bottom tie rods.

1.6.9 Lifting anchors

Lifting anchors are required to allow the precast parts to be moved. They are to be bolted to the relevant stair plates through the holes made by the user on site.

1.6.10 Landings

Landings can be incorporated in the units on request. These are described on pages 20 and 21.

1.7 Maintenance and care

The longitudinal and transverse sliding surfaces on the back wall must be kept clean and regularly greased. The same applies to all the threads of the adjustment spindles and bolts. The formwork surfaces must be sprayed with formwork oil if being used continuously.

If the formwork is not going to be used for a longer period of time, the formwork surface should be greased to protect against rust.

Wird die Schalung längere Zeit nicht eingesetzt, ist die Schalfläche durch Einfetten gegen Rost zu schützen.

1.8 Transport

During unloading by crane, always make sure that the formwork is suspended from the base frame!

Attach the crane lifting tackle to the 4 crane eyes intended for that purpose. Crane chains with four hooks must be used.



Attention:
Hazardous situations can arise if this equipment is not handled properly!



Attention:
Observe the maximum load capacity of the chains! Take into account the total weight of the stairs!



Attention: The formwork may not be suspended by the back wall under any circumstances! Overturning and fall hazard for people!



2. Attaching platforms

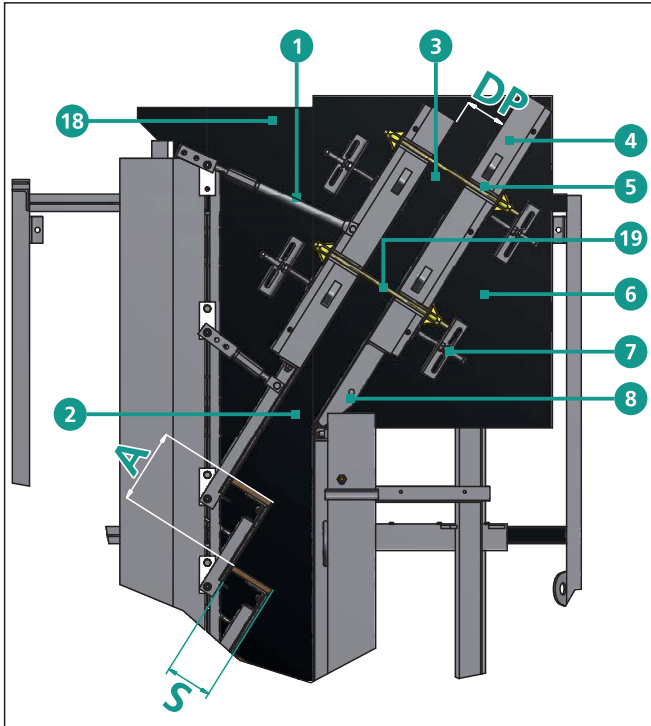

Figure 13.1

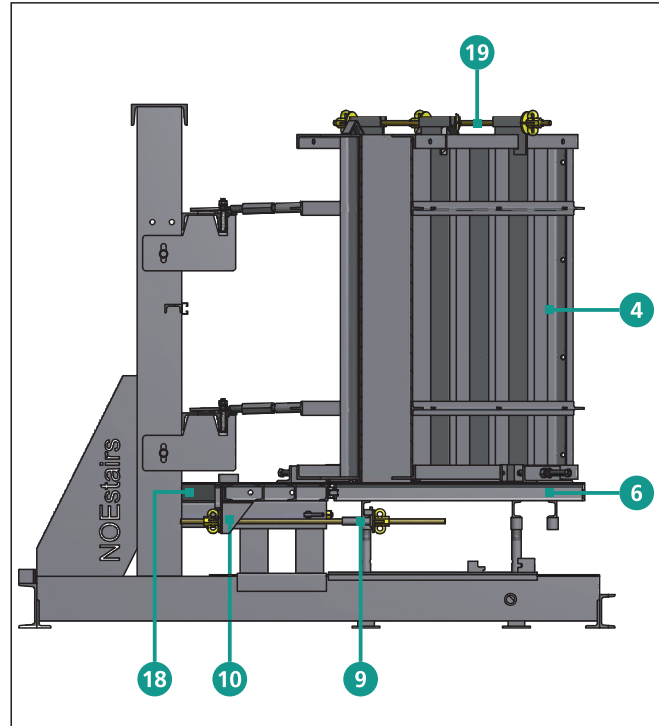

Figure 13.2

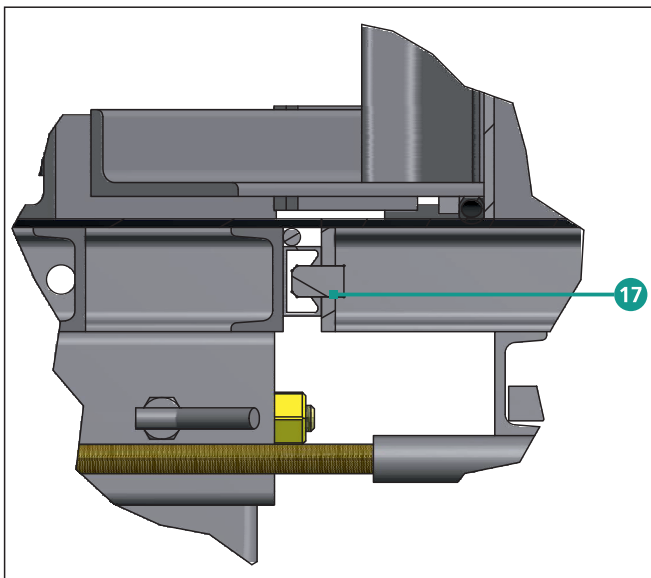

Figure 13.3

1. Basic setting of the NOEstairs stair formwork
Ratio rise (S) / going (A)
2. Connect the bottom of the end stair longitudinally by the locating pin and install tie rods (see Figures 13.2 and 13.3).
3. Bolt the bottom of the start stair on to the end of the stair bottom with 2 bolts M 16x40 (see Figures 14.2 and 14.3).
4. Bolt the platform side parts to the start stair, end stair, wedge piece and connection hinge and set to distance DP.
5. Fix the platform side parts in position with the positioners / adjustment spindles.
6. Fix reinforcement.
7. Attach the site-supplied stop ends.
8. Attach top tie rods.

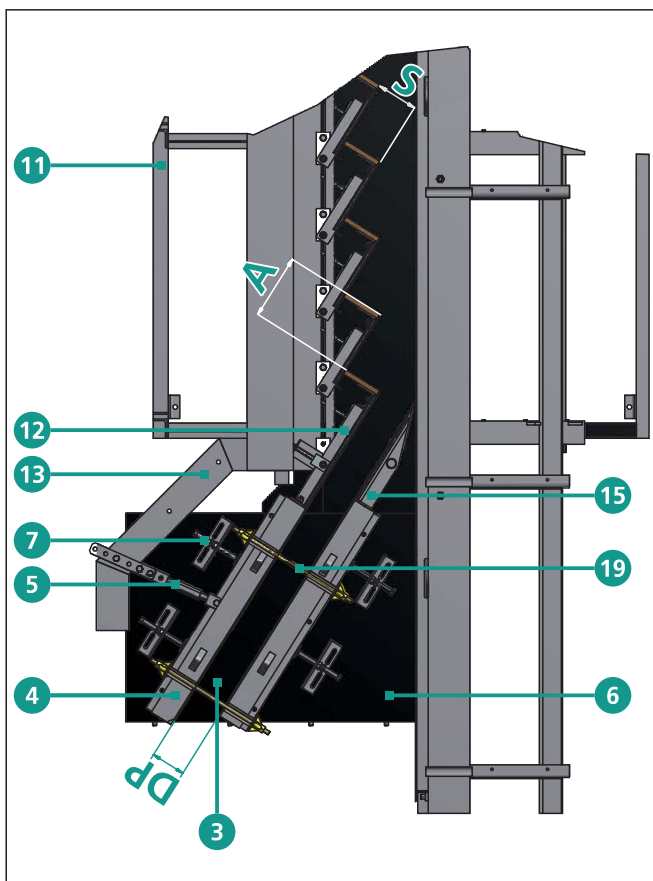

Figure 14.1

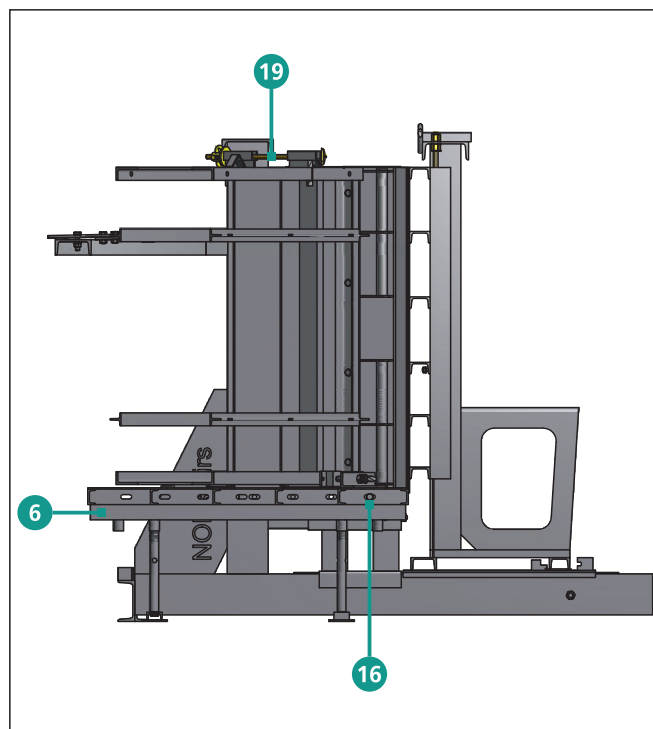

Figure 14.2

1. Positioner with extension
2. End step
3. Site-supplied stop-end
4. Side part 1100 x 1500 (1250) mm
5. Fixing device for platform side part
6. Platform bottom 900 x 1250 mm
7. Adjustment spindles for platform side parts (drilled with bottom on site by contractor)
8. Connection hinge
9. Tying claw small
10. Tying claw large
11. Formwork base frame
12. Start stair
13. Adjuster assembly extension
14. Positioner
15. Wedge piece
16. Bolt M 16x40
17. Locating pin
18. Stair bottom
19. Top tie rod

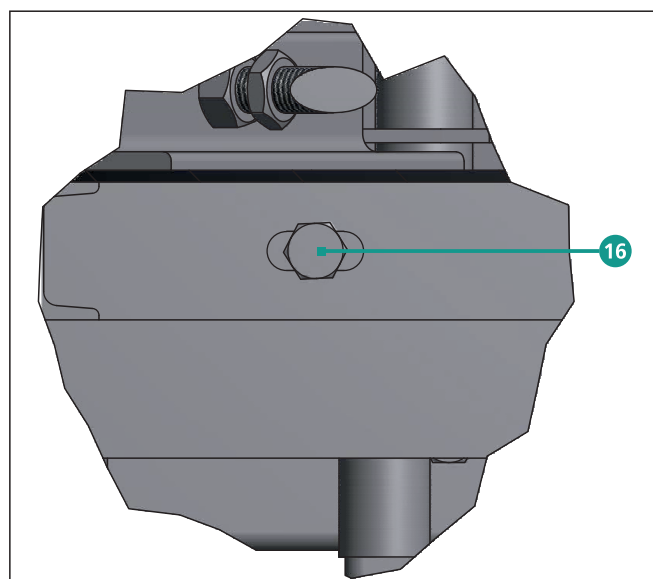

Figure 14.3

3. Setting dimension NOEstairs

Stair formwork for straight flights



Going (A)	220	225	230	235	240	245	250	255	260	265	270
Rise (S)											
150	266,3	270,4	274,6	278,8	283,0	287,3	291,5	295,8	300,2	304,5	308,9
151	266,8	271,0	275,1	279,3	283,6	287,8	292,1	296,4	300,7	305,0	309,4
152	267,4	271,5	275,7	279,9	284,1	288,3	292,6	296,9	301,2	305,5	309,8
153	268,0	272,1	276,2	280,4	284,6	288,8	293,1	297,4	301,7	306,0	310,3
154	268,5	272,7	276,8	281,0	285,2	289,4	293,6	297,9	302,2	306,5	310,8
155	269,1	273,2	277,4	281,5	285,7	289,9	294,2	298,4	302,7	307,0	311,3
156	269,7	273,8	277,9	282,1	286,2	290,4	294,7	298,9	303,2	307,5	311,8
157	270,3	274,4	278,5	282,6	286,8	291,0	295,2	299,5	303,7	308,0	312,3
158	270,9	274,9	279,0	283,2	287,3	291,5	295,7	300,0	304,2	308,5	312,8
159	271,4	275,5	279,6	283,7	287,9	292,1	296,3	300,5	304,8	309,0	313,3
160	272,0	276,1	280,2	284,3	288,4	292,6	296,8	301,0	305,3	309,6	313,8
161	272,6	276,7	280,8	284,9	289,0	293,2	297,4	301,6	305,8	310,1	314,4
162	273,2	277,3	281,3	285,4	289,6	293,7	297,9	302,1	306,3	310,6	314,9
163	273,8	277,8	281,9	286,0	290,1	294,3	298,4	302,6	306,9	311,1	315,4
164	274,4	278,4	282,5	286,6	290,7	294,8	299,0	303,2	307,4	311,6	315,9
165	275,0	279,0	283,1	287,1	291,2	295,4	299,5	303,7	307,9	312,2	316,4
166	275,6	279,6	283,6	287,7	291,8	295,9	300,1	304,3	308,5	312,7	316,9
167	276,2	280,2	284,2	288,3	292,4	296,5	300,6	304,8	309,0	313,2	317,5
168	276,8	280,8	284,8	288,9	293,0	297,1	301,2	305,4	309,6	313,8	318,0
169	277,4	281,4	285,4	289,5	293,5	297,6	301,8	305,9	310,1	314,3	318,5
170	278,0	282,0	286,0	290,0	294,1	298,2	302,3	306,5	310,6	314,8	319,1
171	278,6	282,6	286,6	290,6	294,7	298,8	302,9	307,0	311,2	315,4	319,6
172	279,3	283,2	287,2	291,2	295,3	299,3	303,5	307,6	311,7	315,9	320,1
173	279,9	283,8	287,8	291,8	295,9	299,9	304,0	308,1	312,3	316,5	320,7
174	280,5	284,4	288,4	292,4	296,4	300,5	304,6	308,7	312,9	317,0	321,2
175	281,1	285,0	289,0	293,0	297,0	301,1	305,2	309,3	313,4	317,6	321,8
176	281,7	285,7	289,6	293,6	297,6	301,7	305,7	309,8	314,0	318,1	322,3
177	282,4	286,3	290,2	294,2	298,2	302,2	306,3	310,4	314,5	318,7	322,8
178	283,0	286,9	290,8	294,8	298,8	302,8	306,9	311,0	315,1	319,2	323,4
179	283,6	287,5	291,4	295,4	299,4	303,4	307,5	311,6	315,7	319,8	323,9
180	284,3	288,1	292,1	296,0	300,0	304,0	308,1	312,1	316,2	320,4	324,5
181	284,9	288,8	292,7	296,6	300,6	304,6	308,6	312,7	316,8	320,9	325,1
182	285,5	289,4	293,3	297,2	301,2	305,2	309,2	313,3	317,4	321,5	325,6
183	286,2	290,0	293,9	297,8	301,8	305,8	309,8	313,9	317,9	322,0	326,2
184	286,8	290,7	294,5	298,5	302,4	306,4	310,4	314,5	318,5	322,6	326,7
185	287,4	291,3	295,2	299,1	303,0	307,0	311,0	315,0	319,1	323,2	327,3
186	288,1	291,9	295,8	299,7	303,6	307,6	311,6	315,6	319,7	323,8	327,9
187	288,7	292,6	296,4	300,3	304,3	308,2	312,2	316,2	320,3	324,3	328,4
188	289,4	293,2	297,1	300,9	304,9	308,8	312,8	316,8	320,8	324,9	329,0
189	290,0	293,8	297,7	301,6	305,5	309,4	313,4	317,4	321,4	325,5	329,6
190	290,7	294,5	298,3	302,2	306,1	310,0	314,0	318,0	322,0	326,1	330,2
191	291,3	295,1	299,0	302,8	306,7	310,7	314,6	318,6	322,6	326,7	330,7
192	292,0	295,8	299,6	303,5	307,3	311,3	315,2	319,2	323,2	327,2	331,3
193	292,7	296,4	300,2	304,1	308,0	311,9	315,8	319,8	323,8	327,8	331,9
194	293,3	297,1	300,9	304,7	308,6	312,5	316,4	320,4	324,4	328,4	332,5
195	294,0	297,7	301,5	305,4	309,2	313,1	317,1	321,0	325,0	329,0	333,1
196	294,6	298,4	302,2	306,0	309,9	313,8	317,7	321,6	325,6	329,6	333,6
197	295,3	299,1	302,8	306,6	310,5	314,4	318,3	322,2	326,2	330,2	334,2
198	296,0	299,7	303,5	307,3	311,1	315,0	318,9	322,8	326,8	330,8	334,8
199	296,6	300,4	304,1	307,9	311,8	315,6	319,5	323,5	327,4	331,4	335,4
200	297,3	301,0	304,8	308,6	312,4	316,3	320,2	324,1	328,0	332,0	336,0

All dimensions in mm

275	280	285	290	295	300	305	310	315	320		Going (A) Rise (S)
313,2	317,6	322,1	326,5	330,9	335,4	339,9	344,4	348,9	353,4		150
313,7	318,1	322,5	327,0	331,4	335,9	340,3	344,8	349,3	353,8		151
314,2	318,6	323,0	327,4	331,9	336,3	340,8	345,3	349,8	354,3		152
314,7	319,1	323,5	327,9	332,3	336,8	341,2	345,7	350,2	354,7		153
315,2	319,6	323,9	328,4	332,8	337,2	341,7	346,1	350,6	355,1		154
315,7	320,0	324,4	328,8	333,2	337,7	342,1	346,6	351,1	355,6		155
316,2	320,5	324,9	329,3	333,7	338,1	342,6	347,0	351,5	356,0		156
316,7	321,0	325,4	329,8	334,2	338,6	343,0	347,5	352,0	356,4		157
317,2	321,5	325,9	330,2	334,6	339,1	343,5	347,9	352,4	356,9		158
317,7	322,0	326,4	330,7	335,1	339,5	344,0	348,4	352,9	357,3		159
318,2	322,5	326,8	331,2	335,6	340,0	344,4	348,9	353,3	357,8		160
318,7	323,0	327,3	331,7	336,1	340,5	344,9	349,3	353,8	358,2		161
319,2	323,5	327,8	332,2	336,6	340,9	345,4	349,8	354,2	358,7		162
319,7	324,0	328,3	332,7	337,0	341,4	345,8	350,2	354,7	359,1		163
320,2	324,5	328,8	333,2	337,5	341,9	346,3	350,7	355,1	359,6		164
320,7	325,0	329,3	333,7	338,0	342,4	346,8	351,2	355,6	360,0		165
321,2	325,5	329,8	334,1	338,5	342,9	347,2	351,6	356,1	360,5		166
321,7	326,0	330,3	334,6	339,0	343,3	347,7	352,1	356,5	361,0		167
322,3	326,5	330,8	335,1	339,5	343,8	348,2	352,6	357,0	361,4		168
322,8	327,0	331,3	335,7	340,0	344,3	348,7	353,1	357,5	361,9		169
323,3	327,6	331,9	336,2	340,5	344,8	349,2	353,6	357,9	362,4		170
323,8	328,1	332,4	336,7	341,0	345,3	349,7	354,0	358,4	362,8		171
324,4	328,6	332,9	337,2	341,5	345,8	350,2	354,5	358,9	363,3		172
324,9	329,1	333,4	337,7	342,0	346,3	350,6	355,0	359,4	363,8		173
325,4	329,7	333,9	338,2	342,5	346,8	351,1	355,5	359,9	364,2		174
326,0	330,2	334,4	338,7	343,0	347,3	351,6	356,0	360,3	364,7		175
326,5	330,7	335,0	339,2	343,5	347,8	352,1	356,5	360,8	365,2		176
327,0	331,3	335,5	339,7	344,0	348,3	352,6	357,0	361,3	365,7		177
327,6	331,8	336,0	340,3	344,5	348,8	353,1	357,5	361,8	366,2		178
328,1	332,3	336,6	340,8	345,1	349,3	353,6	358,0	362,3	366,7		179
328,7	332,9	337,1	341,3	345,6	349,9	354,2	358,5	362,8	367,2		180
329,2	333,4	337,6	341,8	346,1	350,4	354,7	359,0	363,3	367,6		181
329,8	334,0	338,2	342,4	346,6	350,9	355,2	359,5	363,8	368,1		182
330,3	334,5	338,7	342,9	347,2	351,4	355,7	360,0	364,3	368,6		183
330,9	335,0	339,2	343,4	347,7	351,9	356,2	360,5	364,8	369,1		184
331,4	335,6	339,8	344,0	348,2	352,5	356,7	361,0	365,3	369,6		185
332,0	336,1	340,3	344,5	348,7	353,0	357,2	361,5	365,8	370,1		186
332,6	336,7	340,9	345,1	349,3	353,5	357,8	362,0	366,3	370,6		187
333,1	337,3	341,4	345,6	349,8	354,0	358,3	362,6	366,8	371,1		188
333,7	337,8	342,0	346,2	350,4	354,6	358,8	363,1	367,3	371,6		189
334,3	338,4	342,5	346,7	350,9	355,1	359,3	363,6	367,9	372,2		190
334,8	338,9	343,1	347,2	351,4	355,6	359,9	364,1	368,4	372,7		191
335,4	339,5	343,6	347,8	352,0	356,2	360,4	364,6	368,9	373,2		192
336,0	340,1	344,2	348,4	352,5	356,7	360,9	365,2	369,4	373,7		193
336,5	340,6	344,8	348,9	353,1	357,3	361,5	365,7	369,9	374,2		194
337,1	341,2	345,3	349,5	353,6	357,8	362,0	366,2	370,5	374,7		195
337,7	341,8	345,9	350,0	354,2	358,4	362,5	366,8	371,0	375,3		196
338,3	342,4	346,5	350,6	354,7	358,9	363,1	367,3	371,5	375,8		197
338,9	342,9	347,0	351,1	355,3	359,4	363,6	367,8	372,1	376,3		198
339,4	343,5	347,6	351,7	355,8	360,0	364,2	368,4	372,6	376,8		199
340,0	344,1	348,2	352,3	356,4	360,6	364,7	368,9	373,1	377,4		200

All dimensions in mm

Example	Rise	S	mm	175,0
	Going	A	mm	280,0
	Setting dim.	Z	mm	330,2



THE FORMWORK



NOE-Schaltechnik Georg Meyer-Keller GmbH + Co. KG

Kuntzestr. 72, 73079 Suessen, Germany
T + 49 7162 13-1
F + 49 7162 13-288
info@noe.de
www.noe.de
www.noeplast.com

Austria

NOE Schaltechnik
www.noe-schaltechnik.at
noe@noe-schaltechnik.at

Belgium

NOE Bekistingtechniek N.V.
www.noe.be
info@noe.be

Brazil

Mills do Brasil
Estruturas e Serviços Ltda.
www.mills.com.br
millsbr@cepa.com.br

Bulgaria

NOE Schaltechnik
www.noebg.com
noe-bg@netbg.com

Croatia

NOE oplatna tehnika d.o.o.
www.noe.hr
noe@noe.hr

France

NOE France
www.noe-france.fr
info@noe-france.fr

Netherlands

NOE Bekistingtechniek b.v.
www.noe.nl
info@noe.nl

Poland

NOE PL Sp Zo.o.
www.noe.com.pl
noe@noe.com.pl

Russia

NOE Moscow
info@noe-moscow.ru

NOE St. Petersburg
noe@sovintel.ru

Saudi Arabia

NOE Global Trade Est.
NOE - The Formwork
www.noe.de
jeddah@noe.de

Serbia

NOE Sistemske Oplate d.o.o.
www.noe-scg.com
noe-scg@eunet.rs

Switzerland

NOE Schaltechnik
www.noe.ch
info@noe.ch