



THE FORMWORK

# NOE<sup>®</sup> HBF

Dated: 07.2022

Assembly and  
Operating Manual

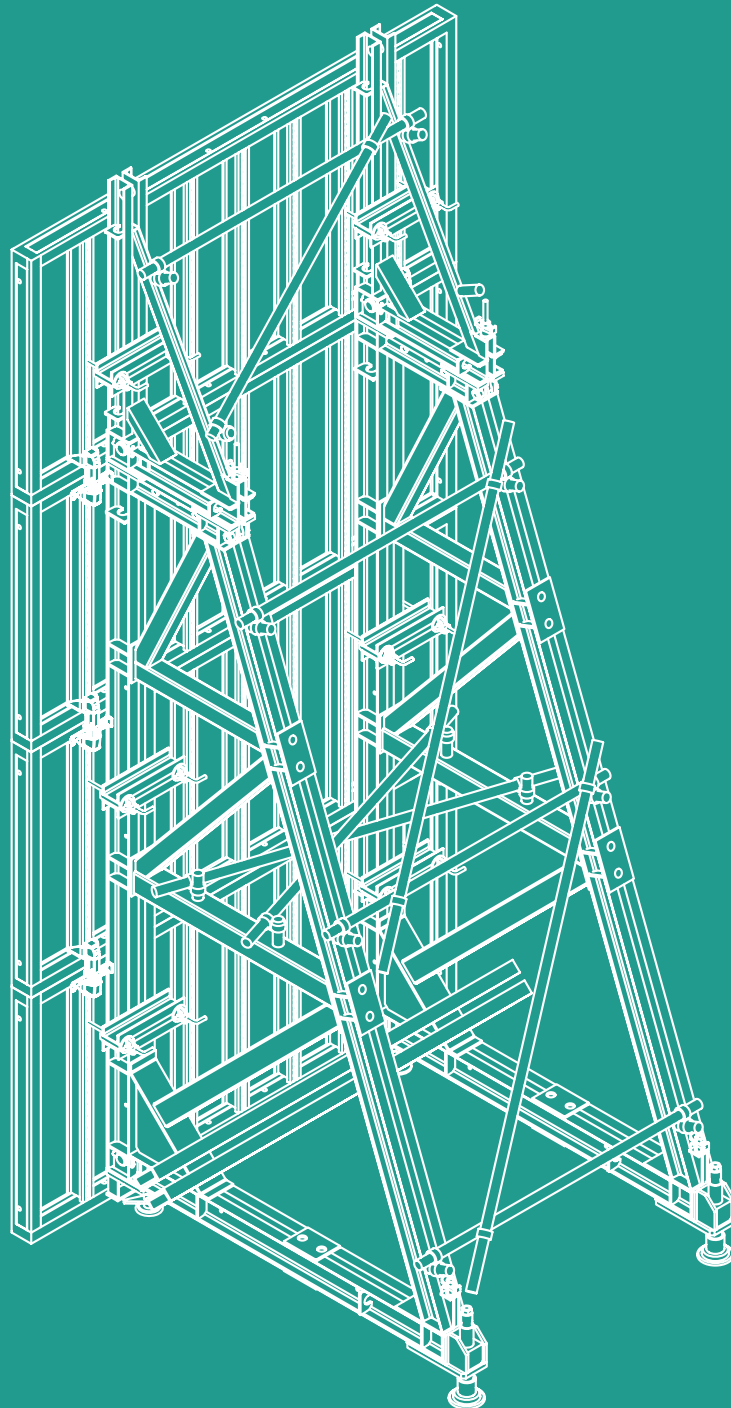

Assembly and Operating Manual  
NOE support bracket



## Contents

	<i>Page</i>	
1	Safety advice, GSV guidelines	4
1.1	Advice on proper and safe use of formwork and falsework	4
1.2	Safety notes for single-sided formwork and structurally stable erection	5
2	System overview NOE support bracket	6
2.1	System parts	7
2.2	System heights	8
2.3	System loading table	9
3	Using the support bracket	10
3.1	Assembling the support brackets	10
3.1.1	Connecting the elements	10
3.1.2	Installation and removal of the boltØ45	11
3.1.3	Attaching the spindles	11
3.2	Number and arrangement of support brackets	12
3.2.1	2 Support brackets for a 2.65 m element width	12
3.2.2	3 Support brackets for a 2.65 m element width	12
3.2.3	4 Support brackets for a 2.65 m element width	13
3.2.4	Tubular bracing	13
3.3	Attaching the formwork	14
3.4	Attaching the tubular stiffening	15
3.5	Attaching at the internal corner	16
3.6	Attaching to NOE R275 circular formwork	17
3.7	Stop-end formwork	18
4	Anchoring the support bracket	19
4.1	Anchors	19
4.2	Installation of the lost anchors	20
4.3	Section showing anchors	21
5	Crane transport and storage	22
5.1	Stacking the elements	22
5.2	Moving horizontal components using a crane	22
5.3	Moving vertical components using a crane	23
6	Individual parts	24
6.1	Support bracket system parts	24
6.2	Support bracket anchoring parts	26
6.3	Support bracket attachment parts	27

# 1. Safety advice, GSV guidelines

## 1.1 Advice on proper and safe use of formwork and falsework

The contractor is responsible for drawing up a comprehensive risk assessment and a set of installation instructions. The latter is not usually identical to the assembly and use instructions.

- Risk assessment: The contractor is responsible for the compilation, documentation, implementation and revision of a risk assessment for each construction site. His employees are obliged to implement the measures resulting from this in accordance with all legal requirements.
- Installation instructions: The contractor is responsible for compiling a written set of installation instructions. The assembly instructions form part of the basis for the compilation of a set of installation instructions.
- Assembly and use instructions: Formwork is technical work equipment and is intended for commercial use only. It must be used properly and exclusively through trained specialist personnel and appropriately qualified supervising personnel. The assembly and use instructions are an integral component of the formwork construction. They comprise at least safety guidelines, details on the standard configuration and proper use, as well as the system description. The functional instructions (standard configuration) contained in the assembly instructions are to be complied with exactly as stated. Enhancements, deviations or changes represent a potential risk and therefore require separate verification (with the help of a risk assessment) or a set of installation instructions that comply with the relevant laws, standards and safety regulations. The same applies in those cases where formwork and/or falsework components are provided by others on site.
- Availability of the assembly and use instructions: The contractor must ensure that the assembly and use instructions provided by the manufacturer or formwork supplier are available at the place of use, that site personnel are informed of this before assembly and use takes place, and that they are available at all times.
- Representations: The representations (drawings, diagrams etc.) shown in the assembly instructions are, in part, situations of assembly and not always complete in terms of safety considerations. Any safety installations that may not have been shown in these representations must nevertheless be available.
- Storage and transportation: Any special requirements relating to transportation procedures and storage of the formwork constructions must be complied with. An example would be the use of the appropriate lifting gear.
- Material check: Formwork and falsework material deliveries are to be checked on arrival at the construction site/place of destination as well as before each use to ensure that they are in perfect condition and function correctly. Changes to the formwork materials are not permitted.
- Spare parts and repairs: Only original components may be used as spare parts. Repairs are to be carried out by the manufacturer or at authorised repair facilities only.
- Use of other products: Combining formwork components from different manufacturers carries certain risks. They are to be individually verified and can result in the compilation of a separate set of assembly instructions required for the installation of the equipment.
- Use of other products: Individual safety symbols are to be complied with. Examples:



Safety information: Non-compliance can lead to damage to materials or risk to the health of site personnel (also life).



Visual check: The intended operation is to be subject to a visual check.



Note: Supplementary information for safe, correct and professional execution of work activities.

- Miscellaneous: We reserve the right to make amendments in the course of technical development. All current country-specific laws, standards and other safety regulations are to be complied with without exception for the safe application and use of the products. They form a part of the obligations of employers and employees regarding industrial safety. This gives rise to, among other things, the responsibility of the contractor to ensure the stability of the formwork and falsework constructions as well as the structure during all stages of construction, which also includes the basic assembly, dismantling and the transport of the formwork and falsework constructions or their components. The complete construction is to be checked during and after assembly.

## 1.2 Safety notes for single-sided formwork and structurally stable erection

When concreting walls with one formed face, the force due to the concrete pressure must be transferred by the formwork and suitable stabilisers and anchors to the supporting ground.

The following instructions must be observed when using NOE support brackets:

- The anchor rods must be designed and installed before concreting the floor slab or foundation.
- The strength of the concrete into which the anchors are installed must be adequate to resist tensile anchor forces.
- Components that have to resist anchor forces must be appropriately designed and reinforced.
- The opposite side of the wall (existing walls, sheet pile excavation linings, and the like) must also be able to carry the concrete pressure.
- To ensure the erected formwork element is structurally stable, it must be suitably anchored to resist tension forces or be secured by other means (e.g. placing of ballast, erection against an existing wall or slope). These measures must be designed by the customer.

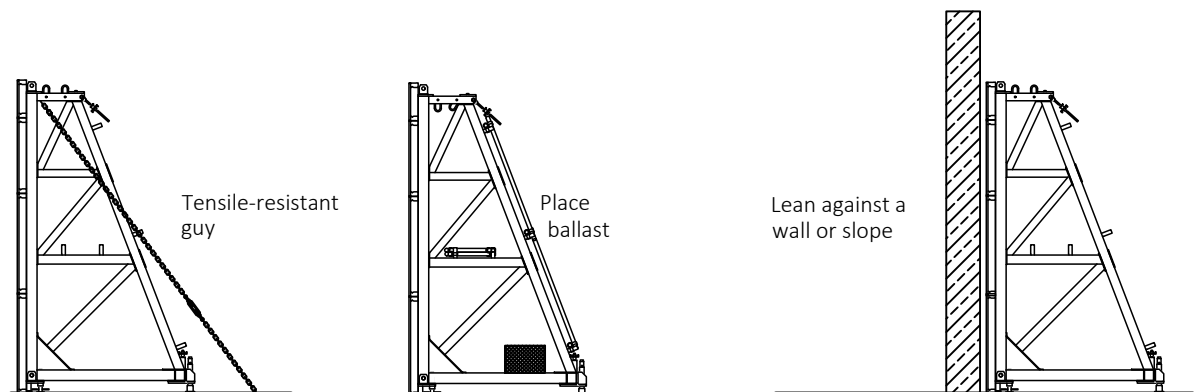

## 2. System overview NOE support bracket

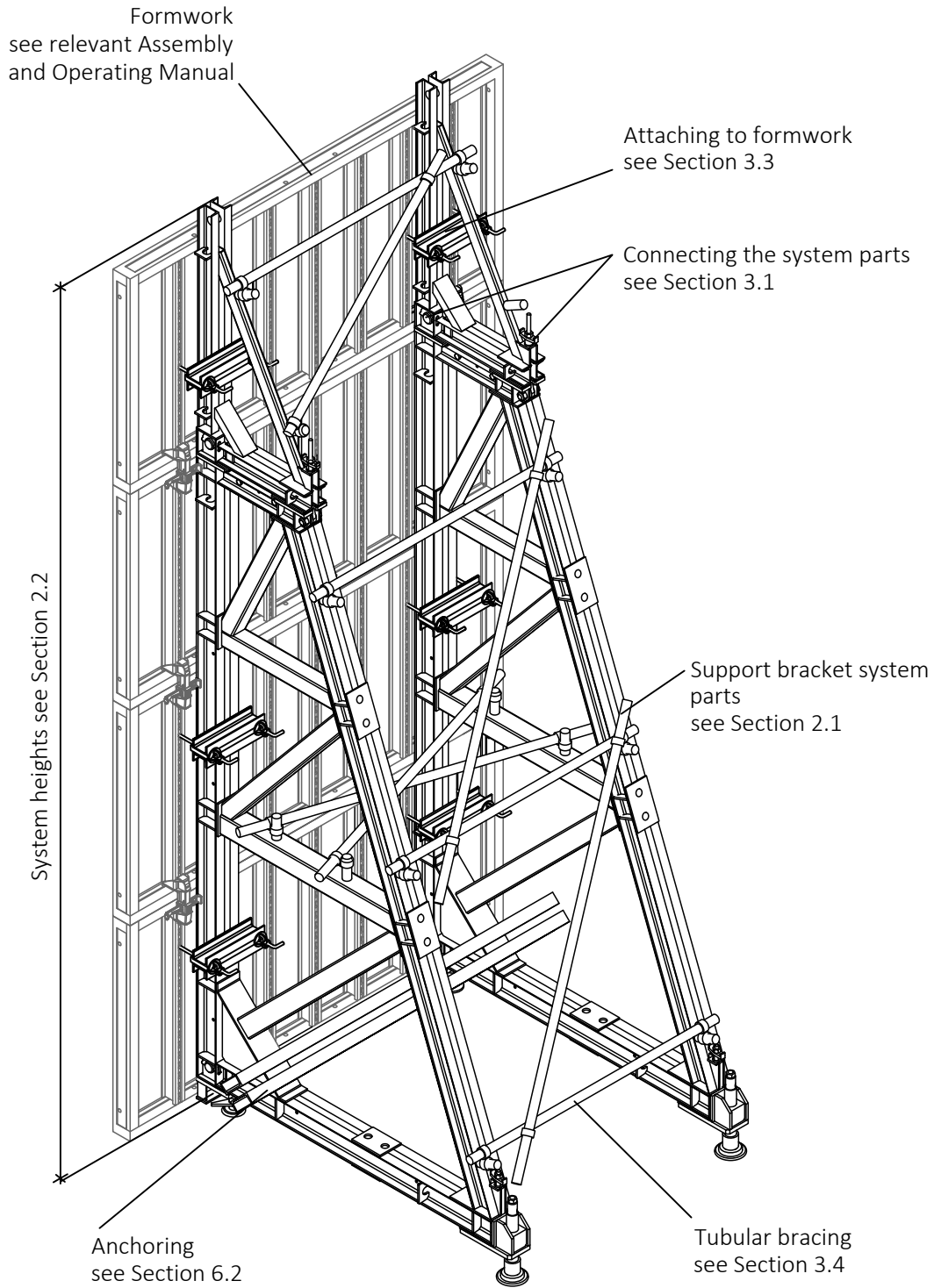

## 2.1 System parts

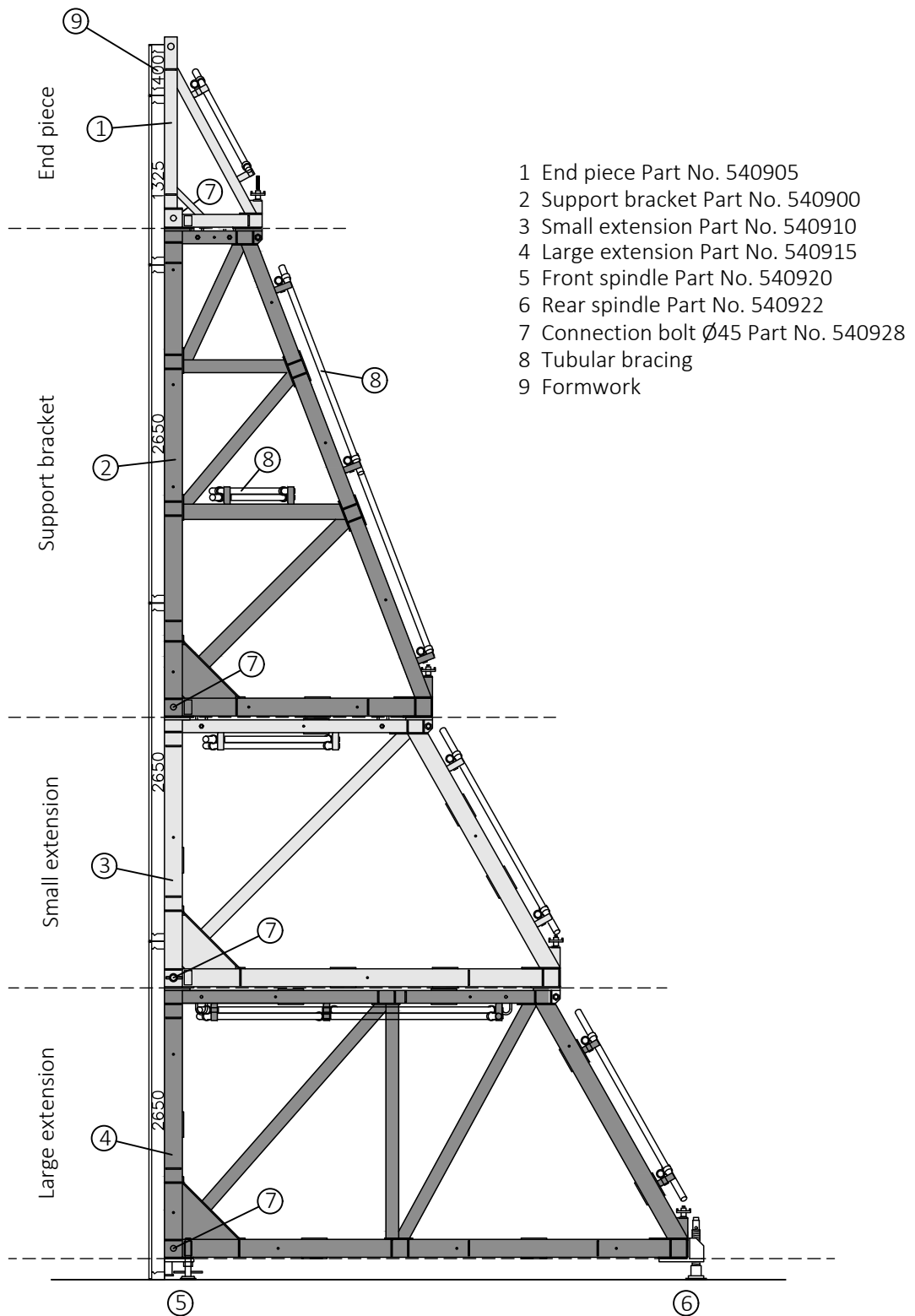

## 2.2 System heights

Including Spindle and 3 cm clearance to the supporting surface.  
Tubular bracing is not shown.

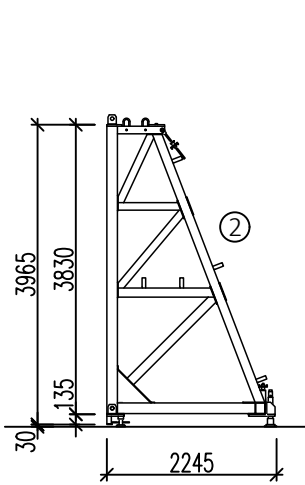

**System A:**  
- support bracket  
- front and rear spindle  
- 1 bolt  
(weight: 510.7 kg)

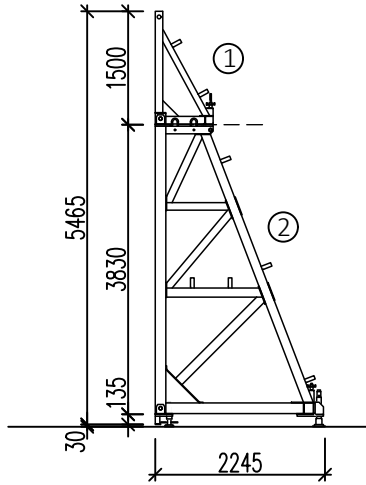

**System B:**  
- end piece  
- support bracket  
- front and rear spindle  
- 2 bolts  
(weight: 586.0 kg)

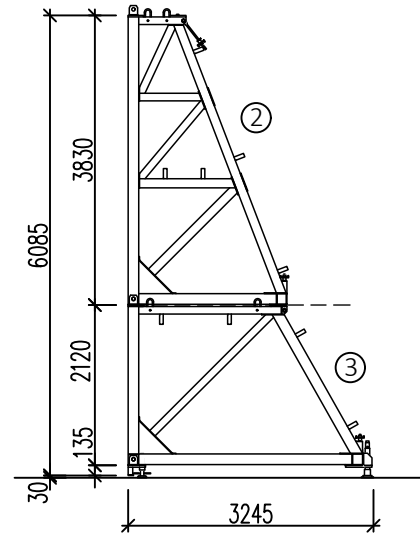

**System C:**  
- support bracket  
- small extension  
- front and rear spindle  
- 2 bolts  
(weight: 881.7 kg)

- 1 End piece
- 2 Support bracket
- 3 Small extension
- 4 Large extension

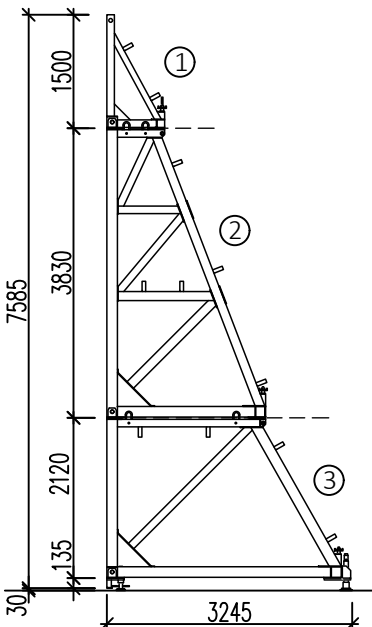

**System D:**  
- end piece  
- support bracket  
- small extension  
- front and rear spindle  
- 3 bolts  
(weight: 957.0 kg)

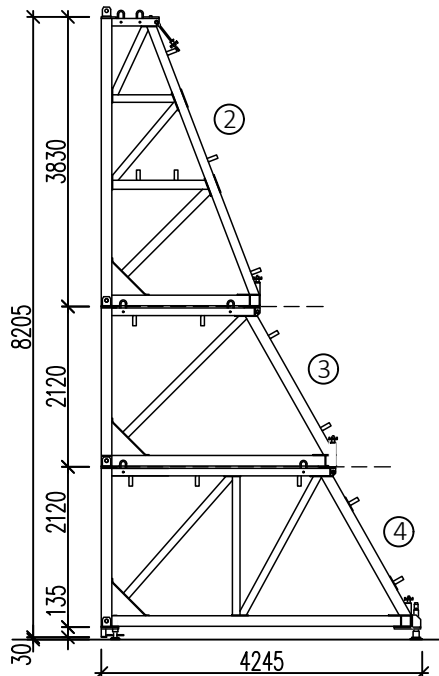

**System E:**  
- support bracket  
- small extension  
- large extension  
- front and rear spindle  
- 3 bolts  
(weight: 1,362.9 kg)

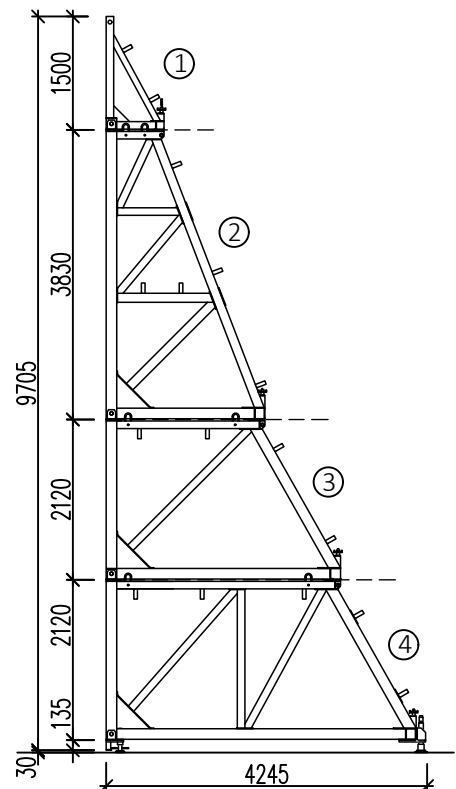

**System F:**  
- end piece  
- support bracket  
- small extension  
- large extension  
- front and rear spindle  
- 4 bolts  
(weight: 1,438.2 kg)



### 2.3 System loading table

System	Concreting height [m]	Effective width [cm]	Brackets per 2.65 m	Concrete pressure p [kN/m <sup>2</sup> ]	Rear spindle D [kN]	Anchor load 2xZ ** [kN]	Anchor rod min. Ø [mm]
Ⓐ	2,80	132,5	2	125 *	190,2	388,5	26,5
	4,00	132,5	2	65	196,0	309,7	20
Ⓑ	4,00	88	3	90 *	179,2	284,0	20
		132,5	2	65	194,9	308,8	20
	5,50	88	3	50	253,2	320,1	26,5
		132,5	2	35	266,9	337,4	26,5
Ⓒ	4,80	88	3	50	127,0	214,1	20
		132,5	2	45	172,2	290,1	20
	6,00	88	3	45	198,3	284,5	20
		132,5	2	35	232,3	333,2	26,5
Ⓓ	4,80	88	3	50	127,2	213,9	20
		132,5	2	45	172,4	289,9	20
	6,00	88	3	45	198,1	284,1	20
		132,5	2	35	232,1	332,7	26,5
	7,50	88	3	35	259,3	330,0	26,5
		132,5	2	25	278,9	355,0	26,5
Ⓔ	5,80	88	3	50	141,5	249,4	20
	7,00	88	3	50	224,2	344,3	26,5
	8,20	88	3	45	291,9	406,1	26,5
Ⓕ	7,00	66	4	55	187,3	285,1	20
	8,20	66	4	50	246,2	340,0	26,5
	9,70	66	4	30	217,1	275,2	20

\* Concrete pressure using NOEtop wall formwork max. 88 kN/m<sup>2</sup>

\*\* Distributed between 2 anchor rod ends, i.e. half of this value per anchor rod end

Permissible tensile load Z:	
Anchor rod Ø20 mm	: 160 kN
Anchor rod Ø26.5 mm	: 250 kN
Waved anchor Ø20	: 160 kN
Waved anchor Ø26.5	: 220 kN
Anchor loop Ø 20	: 160 kN/Anchor rod end
Anchor loop Ø 26.5	: 280 kN/Anchor rod end

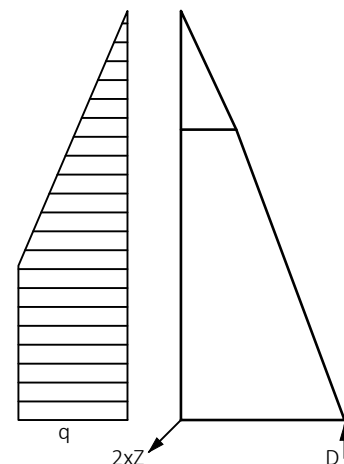

### 3. Using the support bracket

#### 3.1 Assembling the support brackets

##### 3.1.1 Connecting the elements

Assembly is normally done in the horizontal position. Lay out the support bracket on a flat area. Ensure that the crane straps are on the top. Then use the crane to lift, swing and put the extension or extension element down horizontally and connect as shown. Install the front and rear spindles on the bottom element.

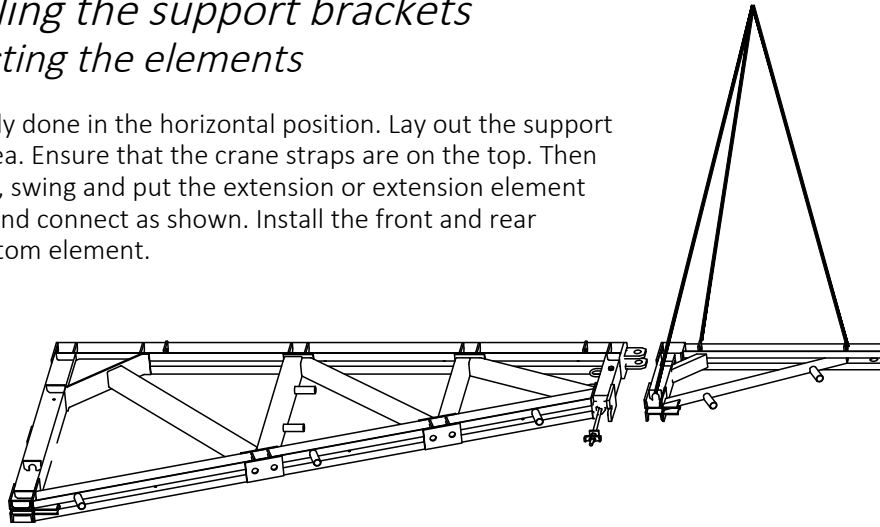

◆ Guide the extension element to engage with the two locating pins.

- 1 Locating pin
- 2 Clamping rod
- 3 Connection bolt  $\varnothing 45$   
Part No. 540928

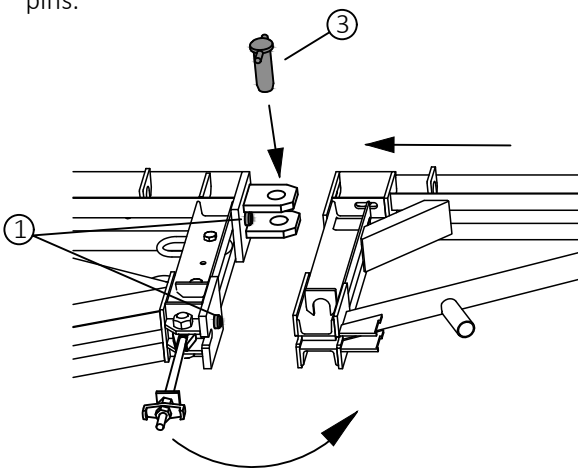

◆ Secure the extension element in place by tightening the clamping rod and installing the bolt  $\varnothing 45$  - see Detail A and refer to next page.

Detail A - Elevation

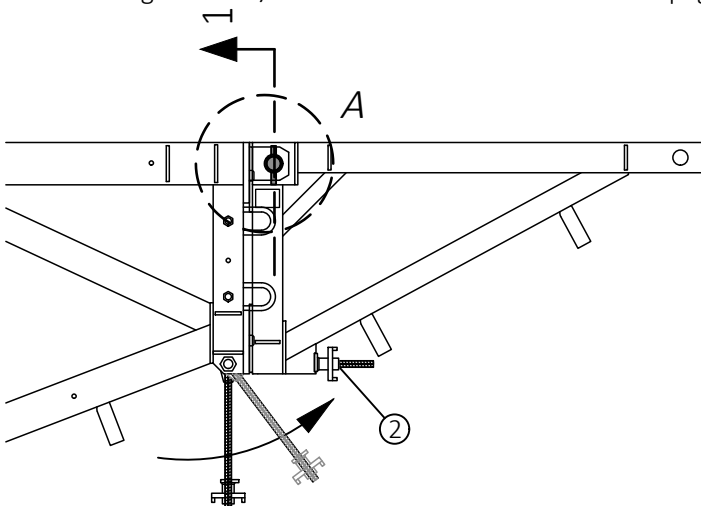
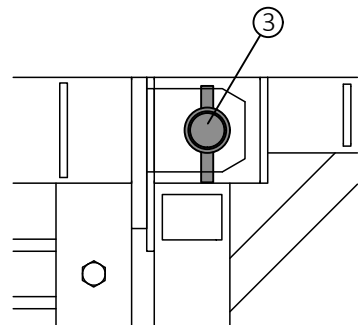

Section 1-1

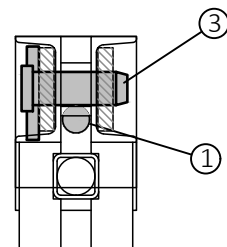

### 3.1.2 Installation and removal of the bolt $\varnothing 45$

#### ◆ Installation of the bolt

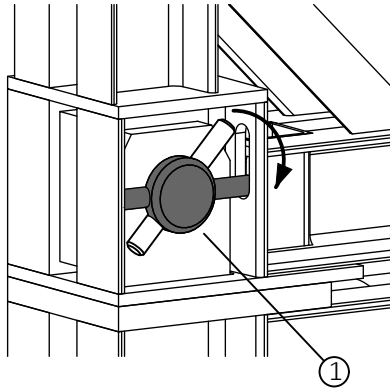

Insert the bolt and rotate it until the safety pin engages into the elongated hole and is secured against falling out.

#### ◆ Removal of the bolt

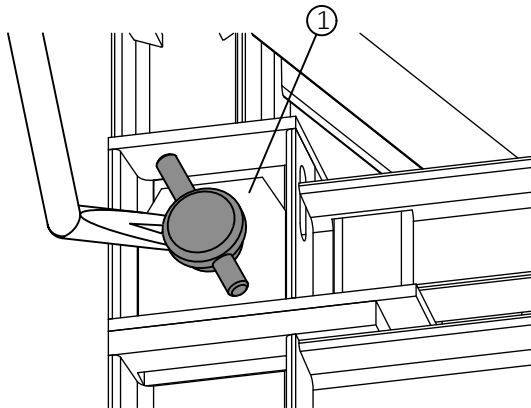

To remove the bolt, rotate it so that the safety pin is not longer inserted in the longitudinal hole. Then prise out the bolt using a pry bar.

- 1 Connection bolt  $\varnothing 45$  Part No. 540928
- 2 Front spindle Part No. 540920
- 3 Rear spindle Part No. 540922

### 3.1.3 Attaching the spindles

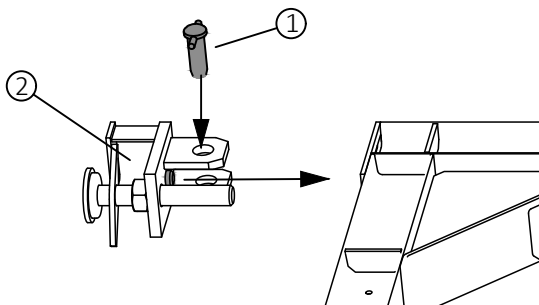

Engage the front spindle mount with the locating pin and secure with the bolt  $\varnothing 45$ . For installation and removal of the bolt see the detail above.

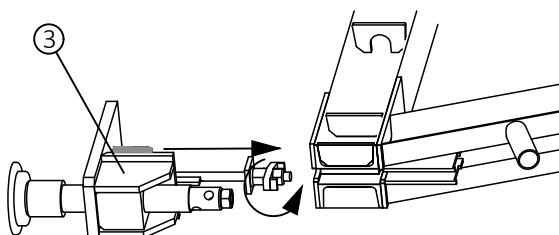

Engage the spindle mount with the rear locating pin. The clamping rod and wing nut now sit in the rear guide. Tighten the wing nut firmly to secure the connection.

### 3.2 Number and arrangement of support brackets

Two anchors are used per support bracket to hold it down.  
 The centre to centre to centre distance between the anchors is 25 cm, i.e. 12.5 cm to the right and left of the central axis of the support bracket.  
 If  $\varnothing 26.5$  mm anchor loops are used, the anchor spacing is 40 cm.

#### 3.2.1 2 Support brackets for a 2.65 m element width

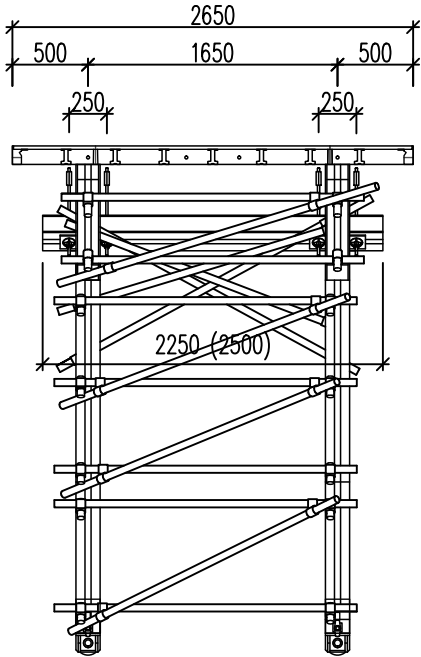

An effective width of 1325 mm allows a maximum system height of 7.50 m.

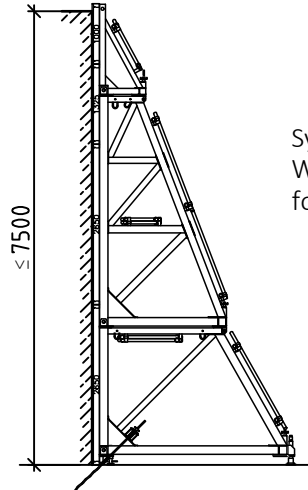

System D:  
 Weight including NOEtop frame  
 formwork: 3.43 tonnes

The support bracket is attached to the formwork with a compensation channel and hammerhead bolts.

#### 3.2.2 3 Support brackets for a 2.65 m element width

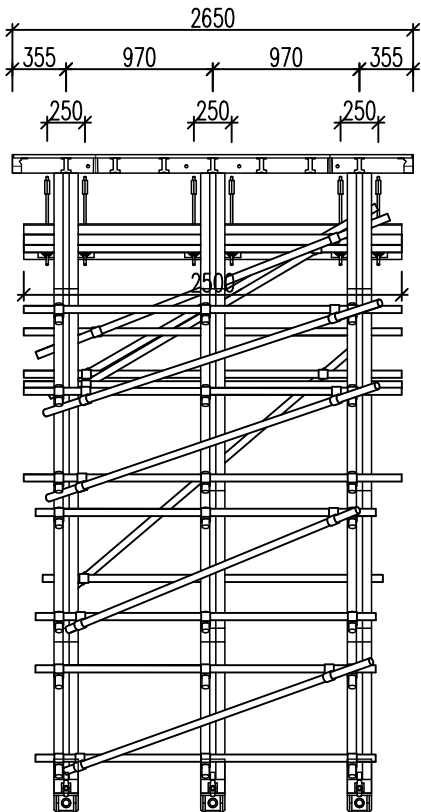

An effective width of 880 mm allows a maximum system height of 8.20 m.

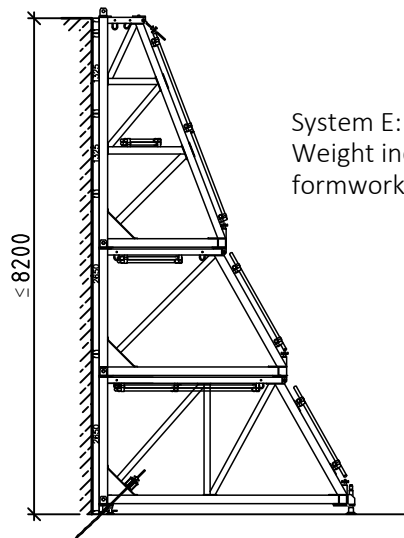

System E:  
 Weight including NOEtop frame  
 formwork: 5.82 tonnes

The support bracket is attached to the formwork with hammerhead bolts. If a large area panel with vertical bracing is used, the middle support bracket must be installed 1 cm off-centre or be attached with a compensation channel and hammerhead bolts because there is no elongated hole in the profile in the centre.

### 3.2.3 4 Support brackets for a 2.65 m element width

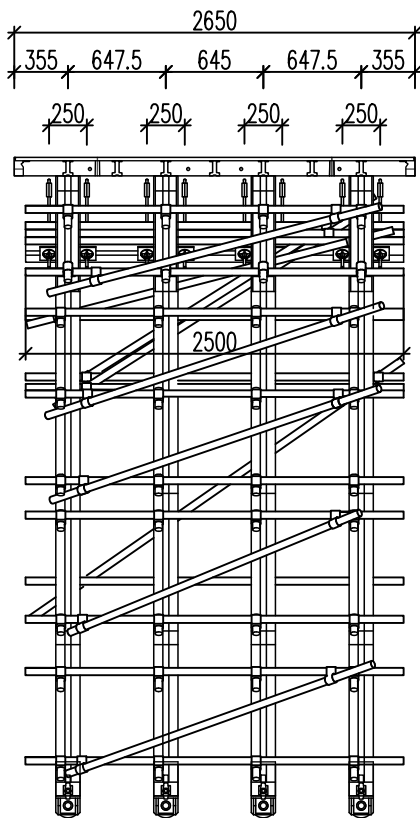

An effective width of 660 mm allows a maximum system height of 9.70 m.

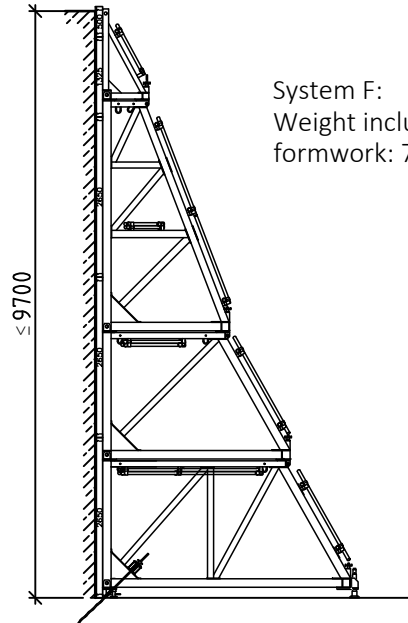

System F:  
Weight including NOEtop frame  
formwork: 7.74 tonnes

The support bracket is attached to the formwork with hammerhead bolts.

### 3.2.4 Tubular bracing

Table of individual parts for the systems shown above

System	Support brackets per 2.65 m	Swivel coupler Part No. 510300	Tube 2.00 m Part No. 502000	Tube 2.50 m Part No. 502500	Tube 3.00 m Part No. 503000
Ⓐ	2	14	5	2	-
Ⓑ	3	27	-	9	2
	2	18	6	3	-
Ⓒ	3	33	1	11	2
	2	24	7	5	-
Ⓓ	3	41	1	14	2
	2	28	8	6	-
Ⓔ	3	51	1	19	2
Ⓕ	4	66	-	21	3

### 3.3 Attaching the formwork

**Attention:**  
If the formwork is moved with the support brackets between uses as one unit, the hammerhead bolts must be checked before every move for tightness!

The support bracket is attached by hammerhead bolts in the profile of the formwork. If there is no profile or elongated hole coinciding with the axis of the support bracket, the attachment must be by compensation channel and hammerhead bolts.

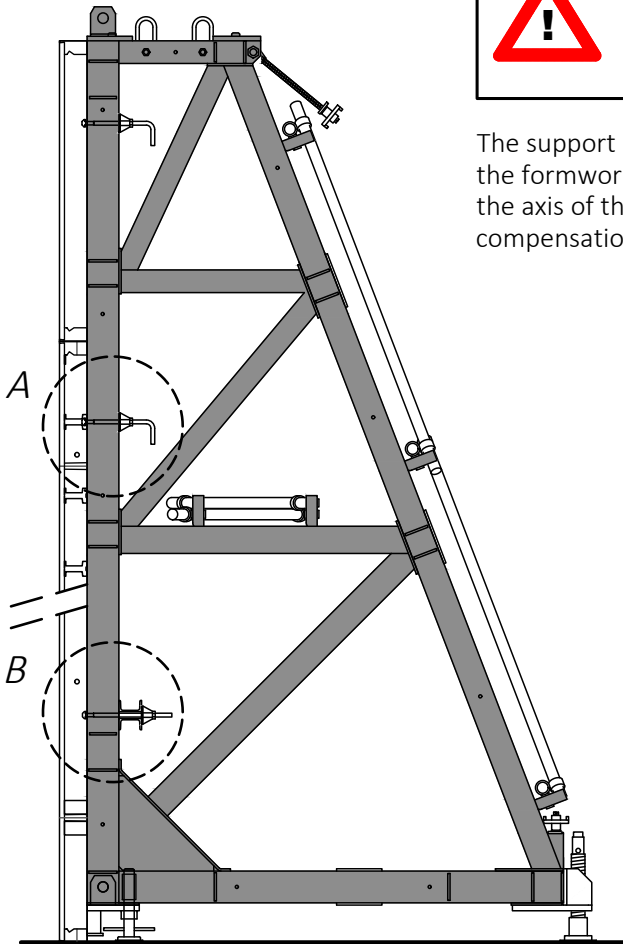

*Detail A - Section*

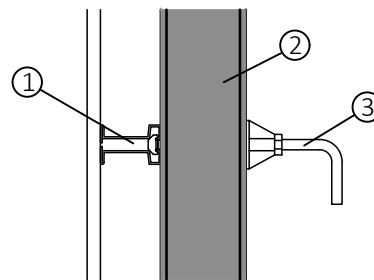

*Detail A - Plan view*

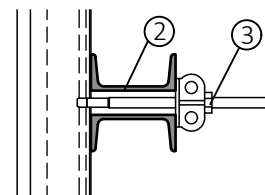

Insert the hammerhead bolt into the elongated hole of the top hat profile, rotate and tighten the sprint nut. The handle of the hammerhead bolt must be transverse to the elongated hole.

#### *Number of attachments*

End piece	1
Support bracket	3
Small extension	2
Large extension	2

*Detail B - Section*

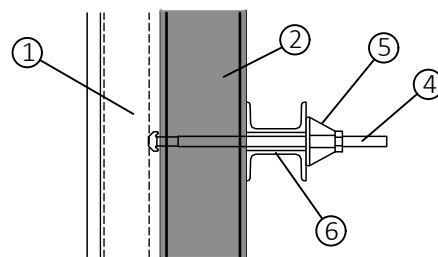

*Detail B - Plan view*

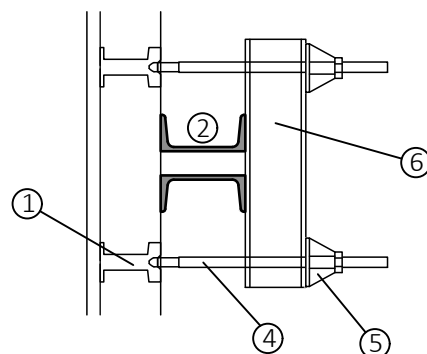

- 1 Top hat profile formwork
- 2 Support bracket or extension
- 3 Hammerhead bolt with handle  
Part No. 319339
- 4 Hammerhead bolt  
Part No. 319315
- 5 Sprint nut Part No. 680580
- 6 Compensation channel Part No. 135109

### 3.4 Attaching the tubular stiffening

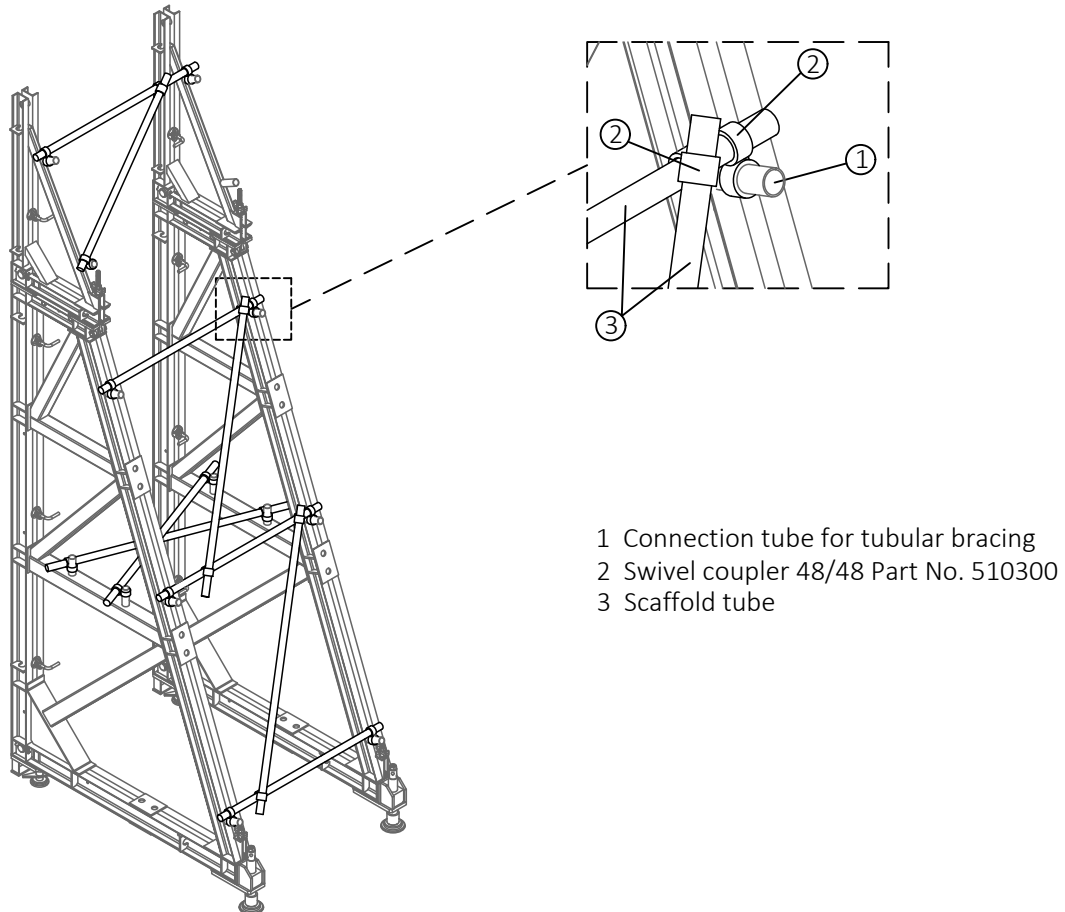

Ø48.3 connection tubes are attached to the system parts for the tubular bracing. The scaffold tubes providing the vertical and horizontal stiffening can be attached to the system parts by swivel couplings.



Attention:  
If the formwork is moved with the support brackets between uses as one unit, the tubular bracing must always be attached.

### 3.5 Attaching at the internal corner

There are two versions: with support bracket or with support bracket with end piece (System A or B).

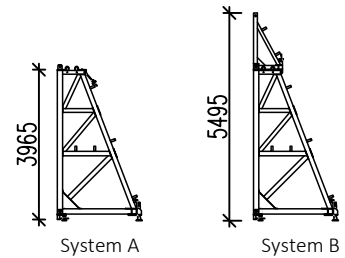
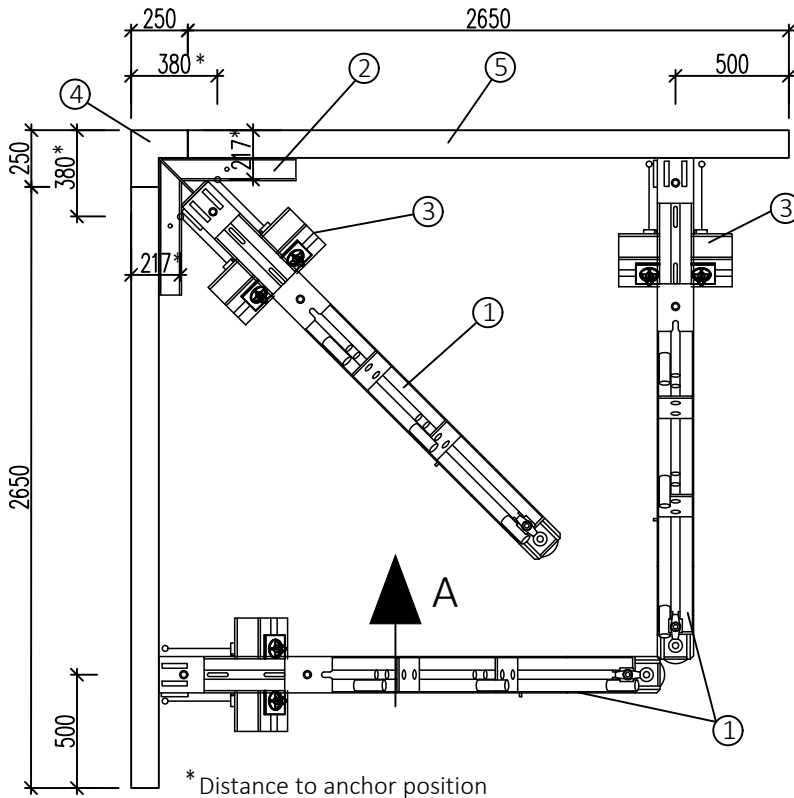

- 1 Support bracket or support bracket with end piece Part No. 540900 if necessary with Part No. 540905
- 2 Corner bracing Part No. 541031
- 3 Bracing Part No. 541032
- 4 Internal corner
- 5 NOE top panel side-on 2650 mm
- 6 Hammerhead bolt with handle Part No. 319338
- 7 Screw base Part No. 117230 with bolt M16x70 Part No. 313800
- 8 Tie rod 30 mm Part No. 670300 and Sprint nut Part No. 680580
- 9 Compensation channel Part No. 135109

Move support bracket and formwork separately!

#### Detail of attachment at corner bracing

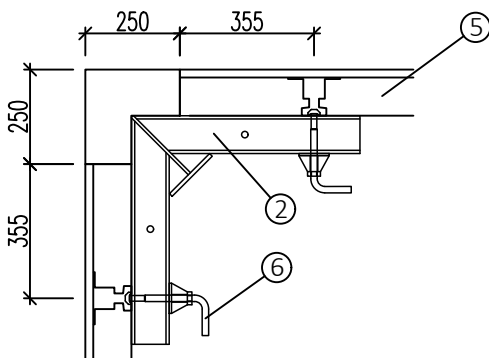

**Attachment :**

The corner bracing is attached on both sides by a hammerhead bolt with handle at the first hole in the top hat profile

**Number required:**

2 corner bracing units per panel for panel widths up to 1325 mm  
 4 corner bracing units for large area panels per 2650 mm

#### Detail of attachment with support bracket in corner

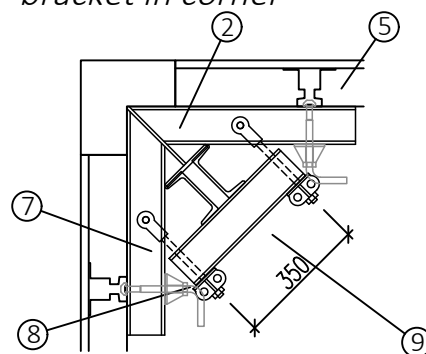

**Attachment:**

The support bracket is attached by 2 screw bases and 2 bolts M16x70, 2 tie rods 300 mm and 2 sprint nuts and a compensation channel.

**Number required:**

1 per support bracket



View A

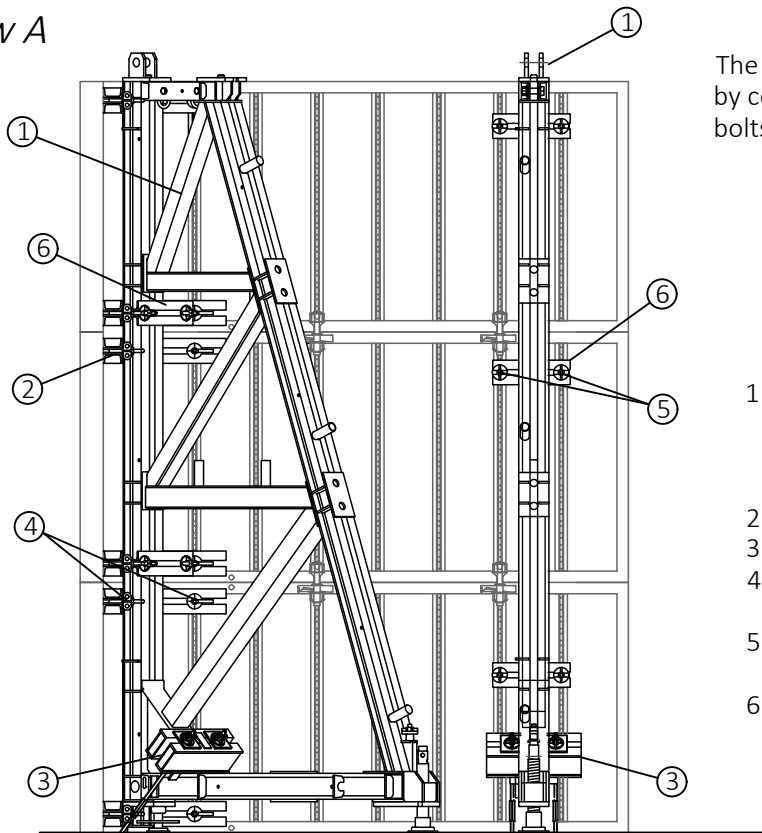

The two outer support brackets are attached by compensation channel and hammerhead bolts (see page 14).

- 1 Support bracket or support bracket with end piece Part No. 540900 if necessary with Part No. 540905
- 2 Corner bracing Part No. 541031
- 3 Bracing Part No. 541032
- 4 Hammerhead bolt with handle Part No. 319338
- 5 Hammerhead bolt Part No. 319315 with Sprint nut Part No. 680580
- 6 Compensation channel Part No. 135109

### 3.6 Attaching to NOE R275 circular formwork

The support bracket is attached to the compensation channel of the NOEtop R275 circular formwork with a compensation channel, 2 tie rods 50 cm, Sprint nut and hexagonal nut.

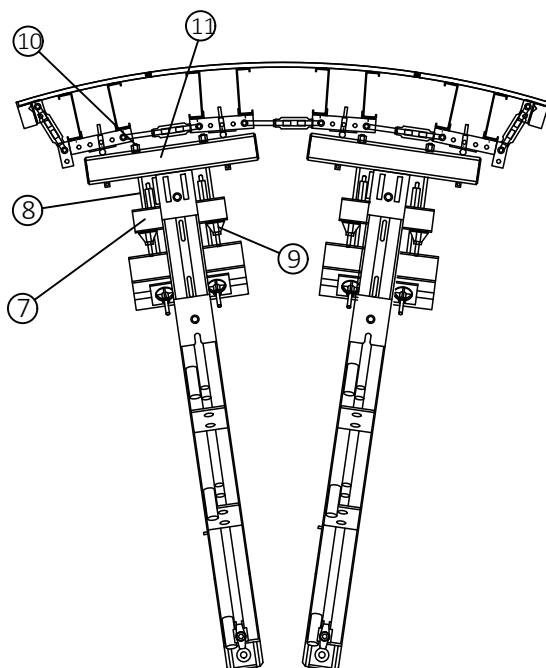

Permissible concrete pressure for circular formwork: 50 kN/m<sup>2</sup>

Permissible concrete pressure for support bracket: see table

The arrangement of the support brackets and anchor rods depends on the radius.

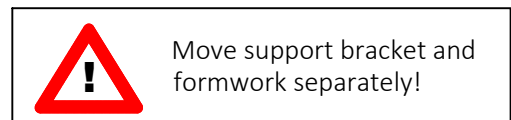

Move support bracket and formwork separately!

- 7 Compensation channel Part No. 135109
- 8 Tie rod 50 cm Part No. 670500
- 9 Sprint nut Part No. 680580
- 10 Hexagonal nut Part No. 680900
- 11 Compensation channel circular formwork R275

### 3.7 Stop-end formwork

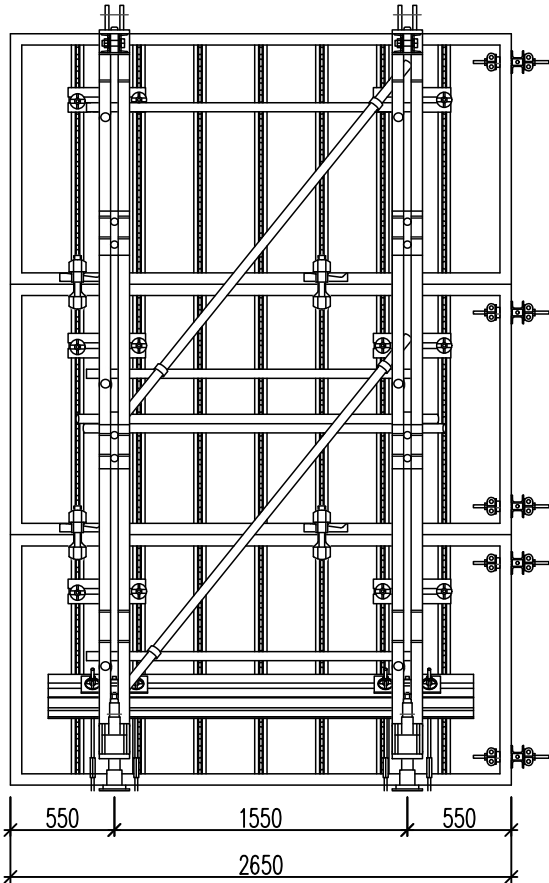

The bracing spacing is determined by the spacing of the transverse holes of the NOEtop panels.

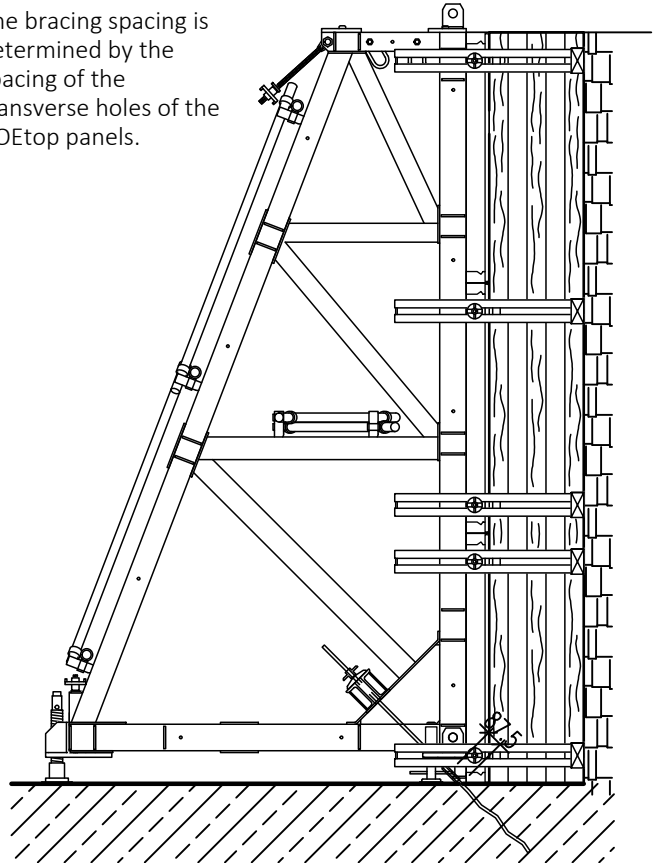

#### Plan view

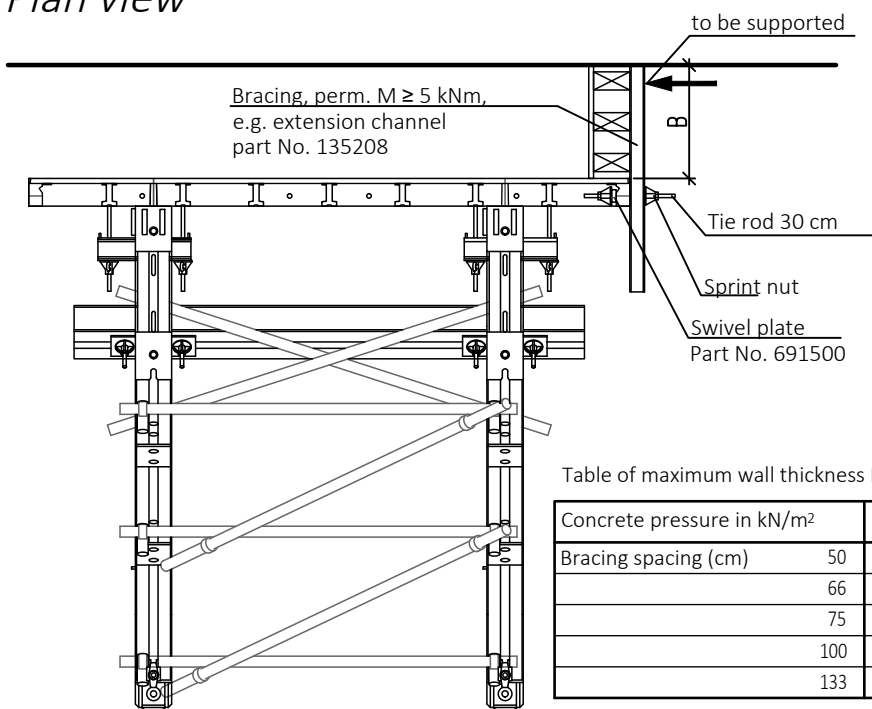

Brace spacing without using the transverse holes

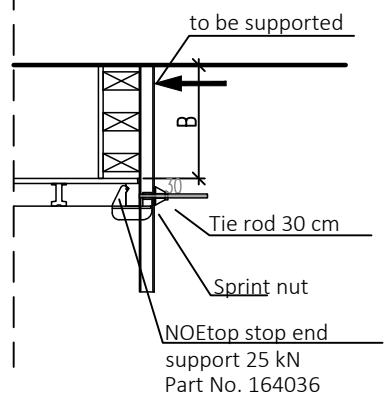

Table of maximum wall thickness B (in cm) using bracing 1000

Concrete pressure in kN/m <sup>2</sup>	30	35	40	45	50	55	60
Bracing spacing (cm)	50	75	70	65	63	60	50
	66	65	60	55	53	50	48
	75	60	55	53	50	47	45
	100	50	47	45	42	40	38
	133	45	40	38	35	34	32

## 4. Anchoring the support bracket

### 4.1 Anchors

Permissible tensile load Z:

Tie rod anchor $\varnothing 20$ mm	: 160 kN
Tie rod anchor $\varnothing 26.5$ mm	: 250 kN
Waved anchor $\varnothing 20$	: 160 kN
Waved anchor $\varnothing 26.5$	: 220 kN
Anchor loop $\varnothing 26.5$	: 280 kN/Anchor rod end
Anchor loop $\varnothing 20$	: 160 kN/Anchor rod end

For the above permissible tensile loads, the concrete compressive strength must be min. 25 MN/m<sup>2</sup>.

For tying, screw the coupler nut onto the cast-in anchor. Make sure that the coupler nut is screwed onto the anchor until it meets the stop. After setting the support bracket, screw the reusable tie rod anchor rod fully into the coupler nut until it meets the stop, and tension with the tying nut and waling plate against the support bracket bracing.

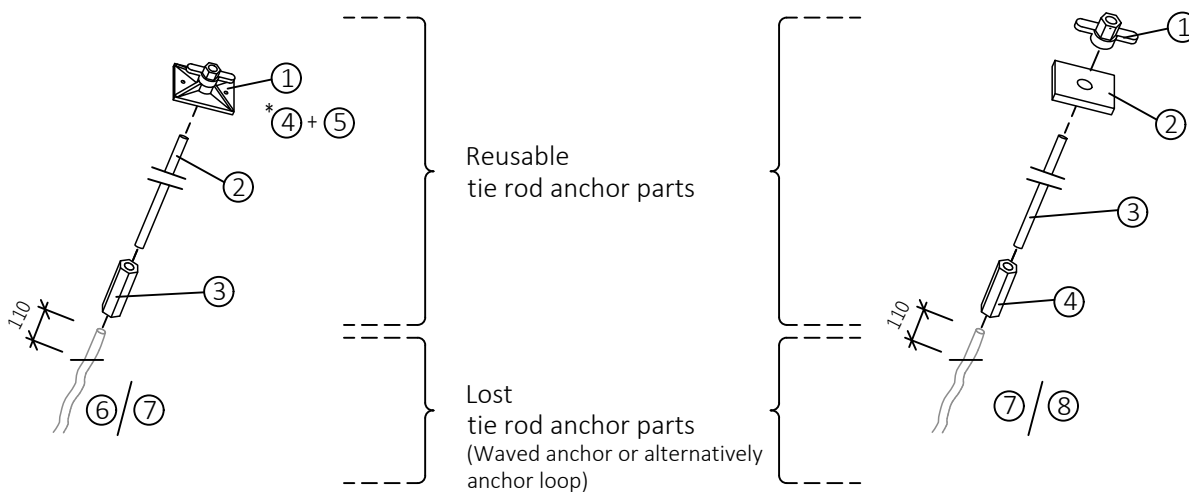

	Ø 20		Weight [kg]
	Part No.	Description	
(1)	691600	Swivel plate w. wing nut $\varnothing 20$	0,40
(2)	670959	Tie rod $\varnothing 20$ 950 mm	0,69
(3)	682220	Coupler nut $\varnothing 20$ wrench size 36	2,40
(4)	* 691509	Waling plate	1,20
(5)	* 680009	Tying nut $\varnothing 20$	1,08
(6)	542008	Waved anchor $\varnothing 20$ 700 mm	2,00
(7)	542014	Anchor loop $\varnothing 20$	3,94

\* Alternative to ①

	Ø 26.5		Weight [kg]
	Part No.	Description	
(1)	680010	Tying nut $\varnothing 26.5$	0,90
(2)	691510	Waling plate 150x150x35 mm	5,70
(3)	660951	Tie rod $\varnothing 26.5$ 950 mm	4,26
(4)	682230	Coupler nut $\varnothing 26.5$ wrench size 46	1,36
(7)	542009	Waved anchor $\varnothing 26.5$ 800 mm	3,58
(8)	542010	Anchor loop $\varnothing 26.5$	8,69

### 4.2 Installation of the lost anchors

Two anchors are used per support bracket to hold it down. The centre to centre distance between the anchors is 25 cm, i.e. 12.5 cm right and left of the central axis of the support bracket.  
 If anchor loops are used for the 26.5 cm version, the anchor spacing is 40 cm.

With projecting anchor rod

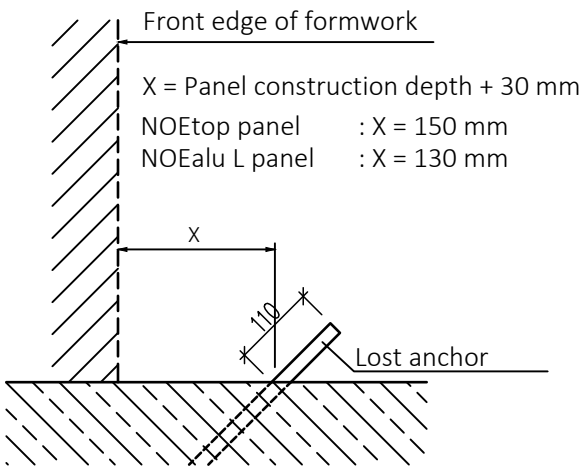

With recessed anchor rod

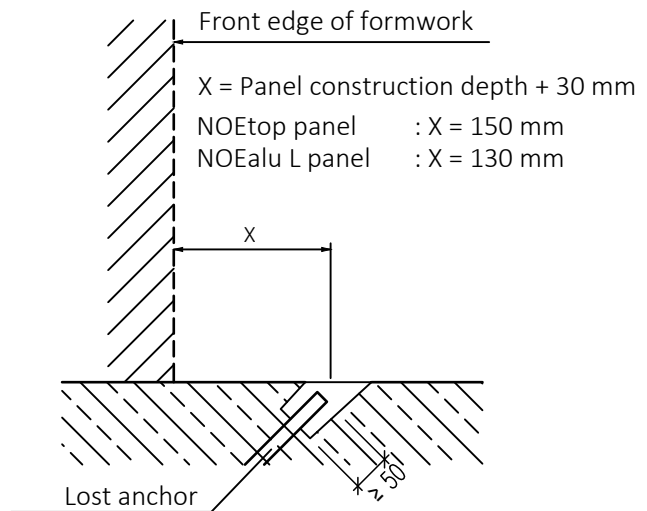

The anchor rod must project a minimum of 50 mm out of the concrete so as to be able to fully screw on the coupler nut.

◆ Conventionally with timber

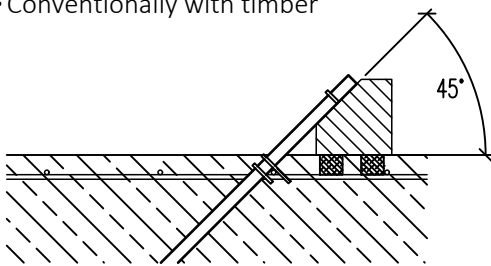

Place bevelled or notched squared timber with markings for the position of the anchor rods on spacer. Tie anchor rod to top and bottom reinforcement and fix to the squared timber.

◆ With anchor support

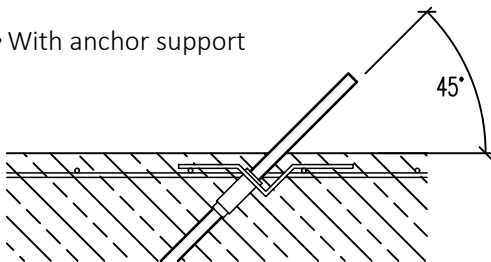

Insert or screw the anchor rod into the anchor support. Tie the anchor support to the top reinforcement.

Anchor support Ø20  
 Anchor support Ø26.5

Part No. 542002  
 Part No. 542003

### 4.3 Section showing anchors

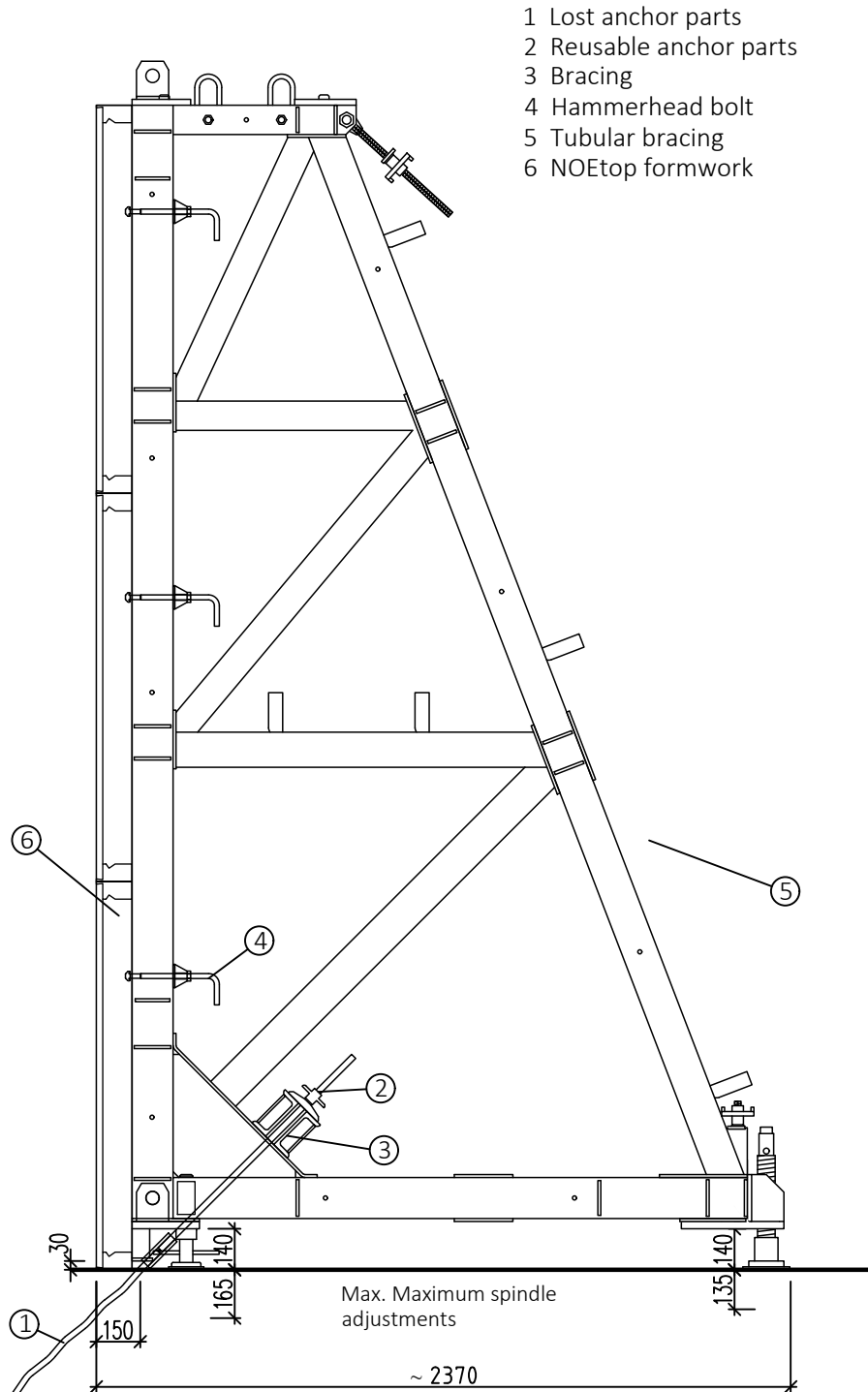

## 5. Crane transport and storage

### 5.1 Stacking the elements

All support bracket system components have 3 crane eyes on one side (see diagram below), which project above the profile and act as lifting points for the crane. They also secure the elements when stored in stacks. The elements must also be secured with belts or lashing straps for transport. If necessary, tie rods can also be inserted through all the aligned holes into which the connection bolts later fit.

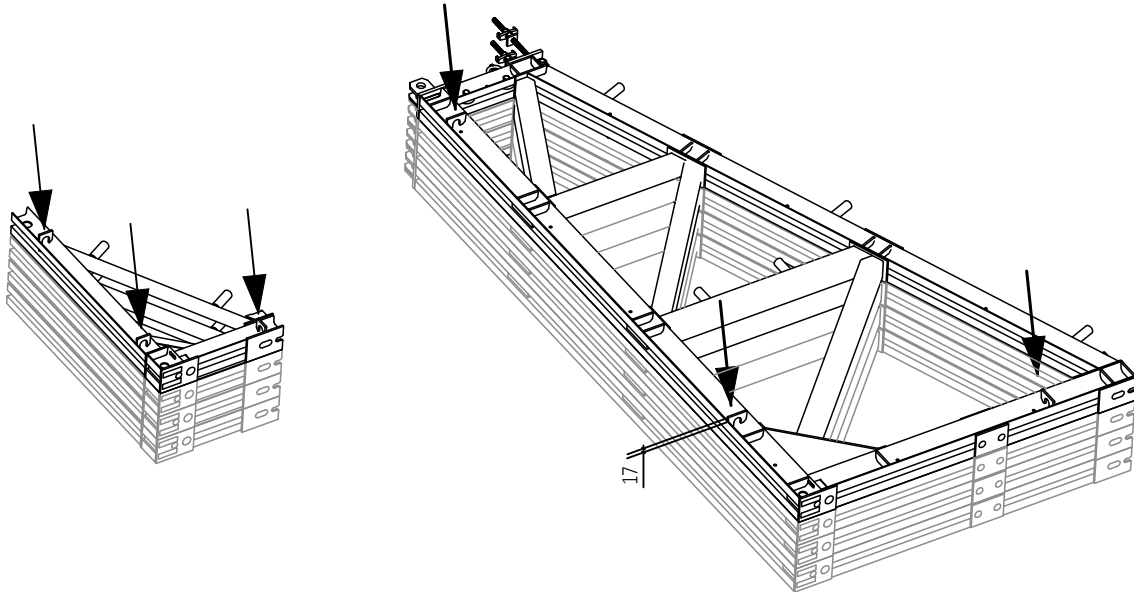

### 5.2 Moving horizontal components using a crane

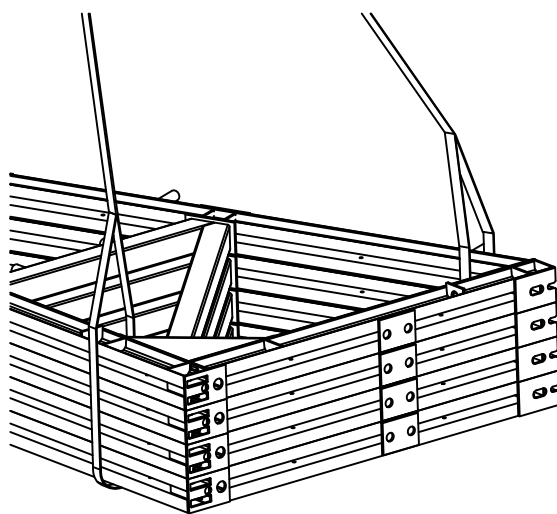

Single elements can be suspended from 3 crane eyes.  
If a stack of elements are to be moved, then this should be done using straps looped around them all.

### 5.3 Moving vertical components using a crane

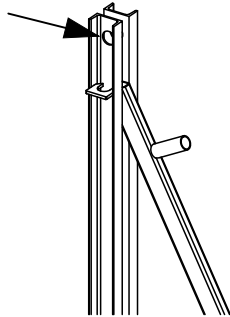

End piece:  
Hole for crane suspension

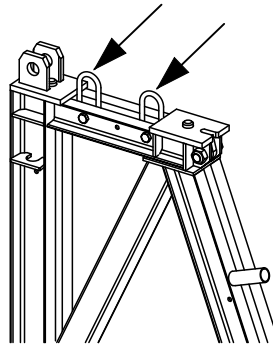

Support bracket and extensions:  
2 Oval rings for crane suspension

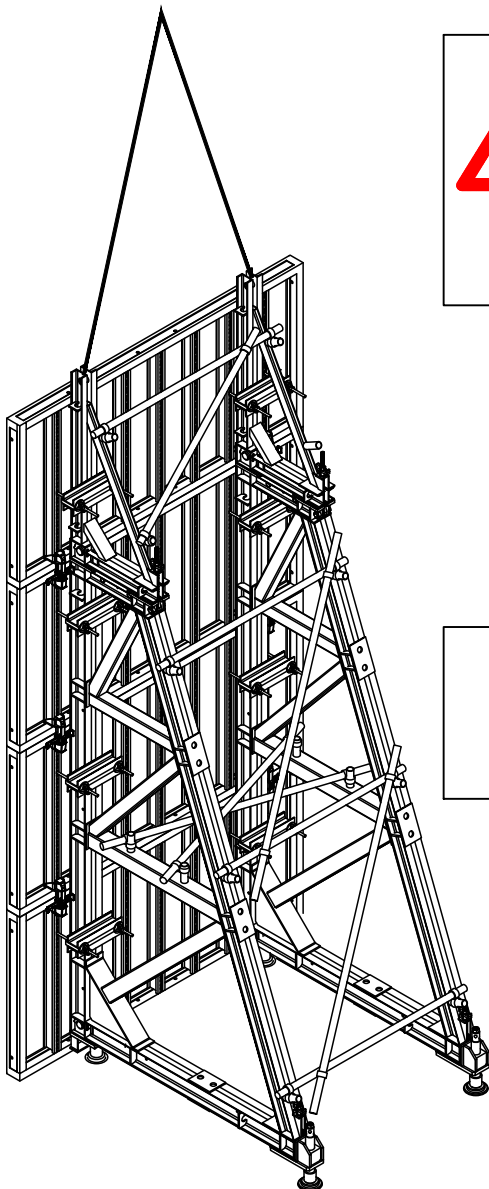

Tubular stiffening is mandatory when moving formwork and support brackets together as one unit!

The connections to the formwork must also be checked for tightness.



When moving the formwork and the support brackets together as one unit, always use the slinging points on the support bracket. Never sling from the formwork!

## 6. Individual parts

### 6.1 Support bracket system parts

#### Support bracket

Part No. 540900  
Weight 466.3 kg

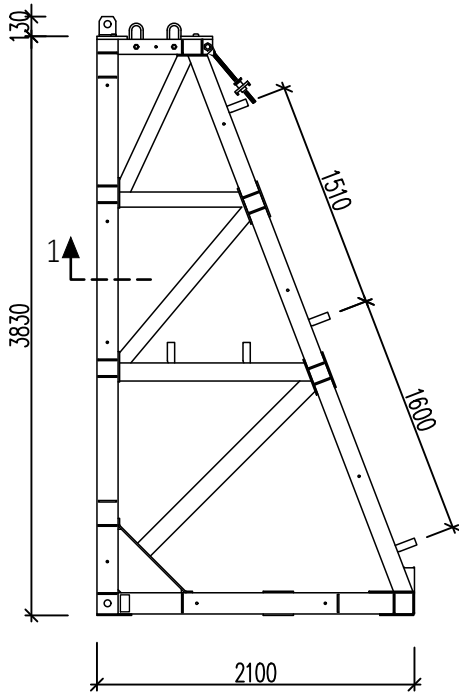

#### End piece

Part No. 540905  
Weight 74.9 kg

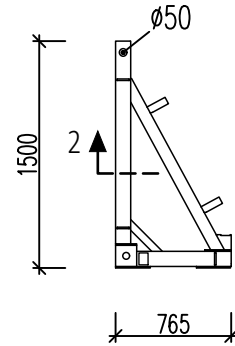

#### Section 1-1

Profile of support bracket and extension  
Double U140

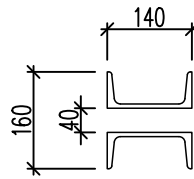

#### Section 2-2

End piece profile  
Double U100

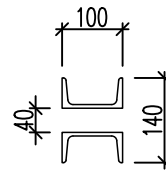

#### Small extension

Part No. 540910  
Weight 370.6 kg

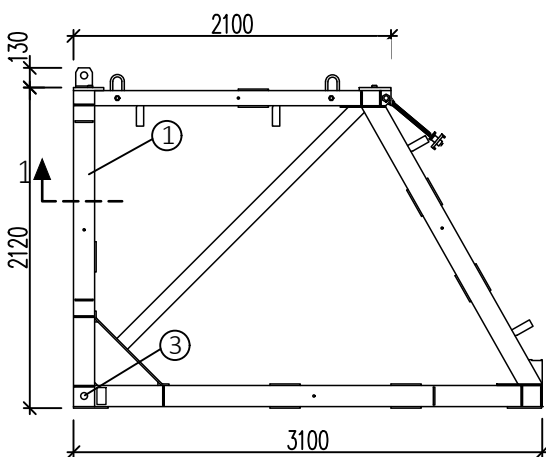

#### Large extension

Part No. 540915  
Weight 480.8 kg

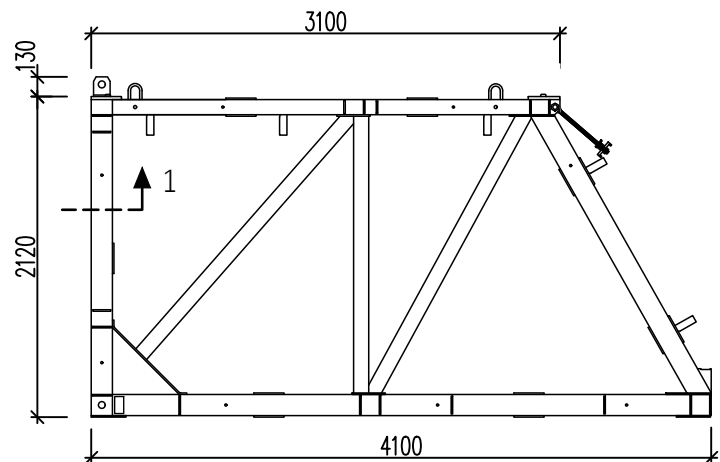



*Front spindle*

Part No. 540920  
Weight 13.1 kg

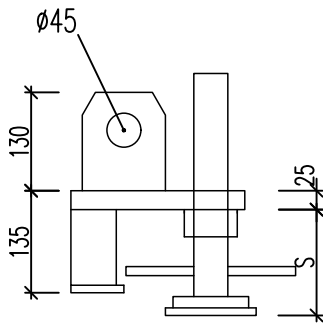

Spindle travel S: 110-305 mm

*Rear spindle*

Part No. 540922  
Weight 30.9 kg

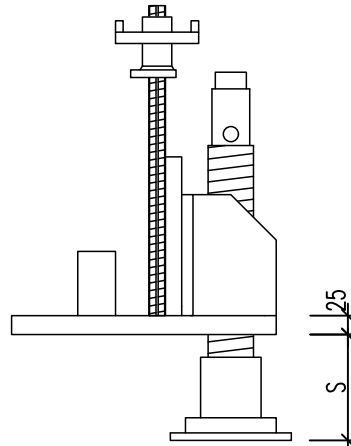

Spindle travel S: 105-275 mm

*Connection bolt d=45*

Part No. 540928  
Weight 0.4 kg

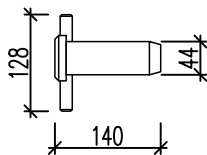

Attention:  
One bolt is needed for each support bracket, end piece and extension!

*Corner bracing*

Part No. 541031  
Weight 29 kg

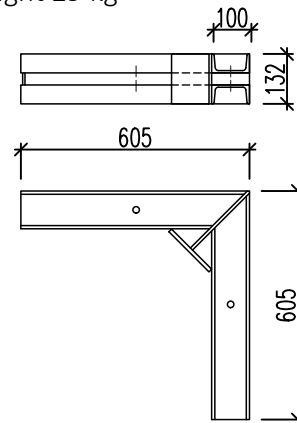

*Swivel coupler 48x48 rotating*

Part No. 510300  
Weight 1.3 kg

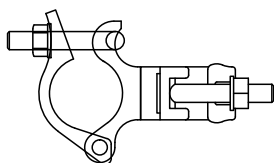

*Scaffold tube*

Part No.	Length [mm]	Weight [kg]
501000	1000	4,40
501500	1500	6,60
502000	2000	8,80
502500	2500	11,00
503000	3000	13,20
503500	3500	15,40
504000	4000	17,60
504500	4500	19,80

### 6.2 Support bracket anchoring parts

Reusable tie rod anchor  $\varnothing 20$  mm or  $\varnothing 26.5$  mm

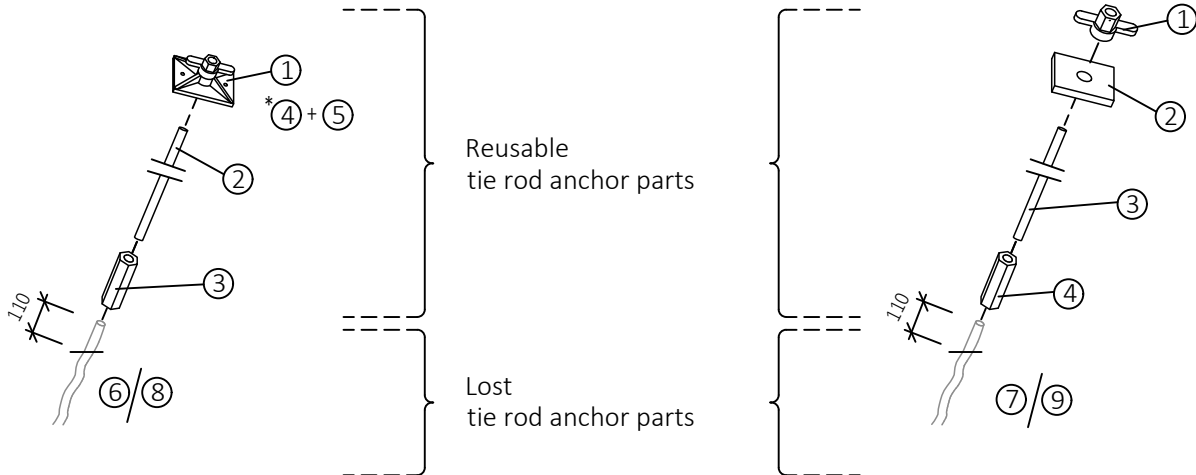

	Part No.	$\varnothing 20$ Description	Weight [kg]
(1)	691600	Swivel plate w. wing nut $\varnothing 20$	0,40
(2)	670959	Tie rod $\varnothing 20$ 950 mm	0,69
(3)	682220	Coupler nut $\varnothing 20$ wrench size 36	2,40
(4)	* 691509	Waling plate	1,20
(5)	* 680009	Tying nut $\varnothing 20$	1,08

	Part No.	$\varnothing 26.5$ Description	Weight [kg]
(1)	680010	Tying nut $\varnothing 26.5$	0,90
(2)	691510	Waling plate 150x150x35 mm	5,70
(3)	660951	Tie rod $\varnothing 26.5$ 950 mm	4,26
(4)	682230	Coupler nut $\varnothing 26.5$ wrench size 46	1,36

\* Alternative to ①

### Lost anchor

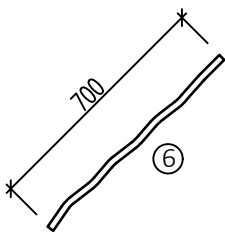

	Part No.	Description	Permis. Z [kN]	Weight [kg]
(6)	542008	Waved anchor $\varnothing 20$ 700 mm	160	2,00
(7)	542009	Waved anchor $\varnothing 26.5$ 800 mm	220	3,58
(8)	542014	Anchor loop $\varnothing 20$	160 *	3,94
(9)	542010	Anchor loop $\varnothing 26.5$	280 *	8,69

\* On each anchor rod end

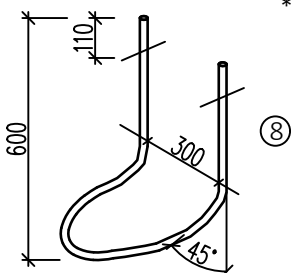
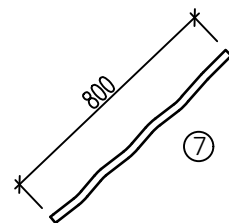

Anchor rod  $\varnothing 20$  mm:  
Permis. 160 kN  
Anchor rod  $\varnothing 26.5$  mm:  
Permis. 250 kN

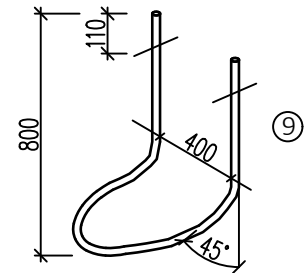

# NOE support bracket



### Bracing 2250 mm

Part No. 541030  
Weight 107 kg

### Bracing 2500 mm

Part No. 541029  
Weight 137 kg

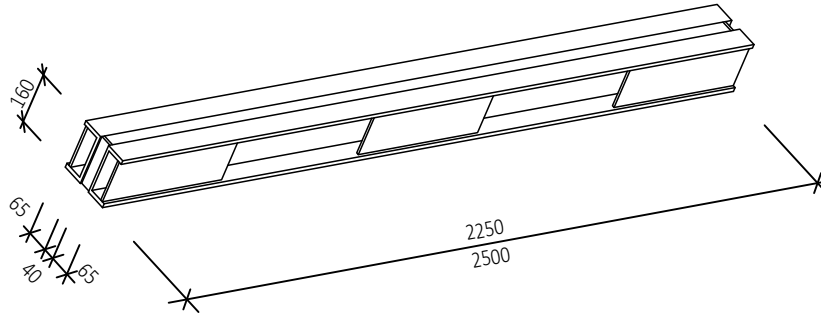

### Bracing

Part No. 541032  
Weight 29 kg

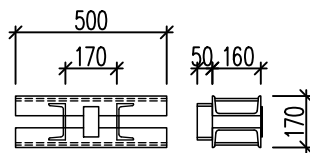

## 6.3 Support bracket attachment parts

### Hammerhead bolt

Length 380 mm  
Part No. 319315  
Weight 0.63 kg

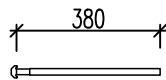

### Sprint nut

Part No. 380580  
Weight 0.69 kg



### Hammerhead bolt with handle

Clamp length 125  
Part No. 319338  
Weight 1.15 kg

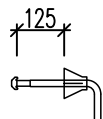

### Hammerhead bolt with handle

Clamp length 205  
Part No. 319339  
Weight 1.23 kg

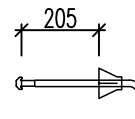

### Compensation channel

Part No. 135109  
Weight 9.43 kg

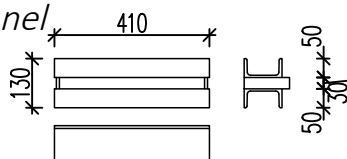



**THE FORMWORK**



**NOE-Schaltechnik  
Georg Meyer-Keller GmbH + Co. KG**

Kuntzestrasse 72, 73079 Süssen, Germany  
T + 49 7162 13-1  
F + 49 7162 13-288  
info@noe.de  
www.noe.eu

**Belgium**

NOE-Bekistingtechniek N.V.  
info@noe.be  
www.noe.eu

**France**

NOE-France  
info@noefrance.fr  
www.noe.eu

**Netherlands**

NOE-Bekistingtechniek b.v.  
info@noe.nl  
www.noe.eu

**Austria**

NOE-Schaltechnik  
noe@noe-schaltechnik.at  
www.noe.eu

**Poland**

NOE-PL Sp. Zo.o.  
noe@noe.pl  
www.noe.pl

**Switzerland**

NOE-Schaltechnik  
info@noe.ch  
www.noe.eu