



THE FORMWORK



# NOE<sup>®</sup> AB 300

Dated: 01.2021

**Assembly and  
Operating Manual**



<i>Contents</i>	<i>Page</i>
1. Safety advice, GSV Guide	4
1.1 Advice on proper and safe use of formwork and falsework	4
2. System overview	
2.1 System description	5
2.2 Scope of application	5
2.3 Schematic diagram	6
2.4 Standard dimensions	6
2.5 Transport height and dimensions	6
3. Scaffolding units	7
4. Assembly	
4.1 Assembly process for working platform	9
4.2 Working platform with suspended lower platform	11
4.3 Tables of parts for suspended lower platform	12
4.4 Assembly process lower platform	13
4.5 Assembly process for unit with hatch and ladder ascent	17
5. Scaffold suspension	
5.1 Available play when installing the suspension hooks	22
5.2 Details of central and eccentric hook arrangement	23
5.3 Fastening the suspension hooks with screw anchor M36x430	24
5.4 Fastening the suspension hook with scaffold bolt M36	25
5.5 Fastening the suspension hook with removable tie cone Tr26x5	26
5.6 Suspending the scaffold unit	27
5.7 Tying down against wind uplift on the panels	28
6. Use with travelling channel and travelling device	
6.1 Overview	29
6.2 Use of the AB300	30
6.3 Mounting the runner on the bracket	30
6.4 Install support tube and panel system	32
6.5 Retract the formwork panel	34
6.6 Climbing process without travelling device	35
7. Use without travelling device	
7.1 NOEtop formwork with AB300 support channel	36
7.2 Formwork panel without travelling device	37
8. Practical solutions for various situations	
8.1 Bridging wall openings	38
8.2 Guard rail extension with protective net	39
8.3 Internal corner	40
8.4 External corner	41
8.5 Assembly of the external corner	42
8.6 End guard rail	43
8.7 Connecting platform	44
8.8 Connecting lower platform	45
8.9 Scaffold extension	46
9. Individual parts of the travelling device	47
10. Overview of parts for 1 climbing bracket	50

## 1. Safety advice, GSV guidelines

### 1.1 Advice on proper and safe use of formwork and falsework

The contractor is responsible for drawing up a comprehensive risk assessment and a set of installation instructions. The latter is not usually identical to the assembly and use instructions.

- **Risk assessment:** The contractor is responsible for the compilation, documentation, implementation and revision of a risk assessment for each construction site. His employees are obliged to implement the measures resulting from this in accordance with all legal requirements.
- **Installation instructions:** The contractor is responsible for compiling a written set of installation instructions. The assembly instructions form part of the basis for the compilation of a set of installation instructions.
- **Assembly and use instructions:** Formwork is technical work equipment and is intended for commercial use only. It must be used properly and exclusively through trained specialist personnel and appropriately qualified supervising personnel. The assembly and use instructions are an integral component of the formwork construction. They comprise at least safety guidelines, details on the standard configuration and proper use, as well as the system description. The functional instructions (standard configuration) contained in the assembly instructions are to be complied with exactly as stated. Enhancements, deviations or changes represent a potential risk and therefore require separate verification (with the help of a risk assessment) or a set of installation instructions that comply with the relevant laws, standards and safety regulations. The same applies in those cases where formwork and/or falsework components are provided by others on site.
- **Availability of the assembly and use instructions:** The contractor must ensure that the assembly and use instructions provided by the manufacturer or formwork supplier are available at the place of use, that site personnel are informed of this before assembly and use takes place, and that they are available at all times.
- **Representations:** The representations (drawings, diagrams etc.) shown in the assembly instructions are, in part, situations of assembly and not always complete in terms of safety considerations. Any safety installations that may not have been shown in these representations must nevertheless be available.
- **Storage and transportation:** Any special requirements relating to transportation procedures and storage of the formwork constructions must be complied with. An example would be the use of the appropriate lifting gear.
- **Material check:** Formwork and falsework material deliveries are to be checked on arrival at the construction site/place of destination as well as before each use to ensure that they are in perfect condition and function correctly. Changes to the formwork materials are not permitted.
- **Spare parts and repairs:** Only original components may be used as spare parts. Repairs are to be carried out by the manufacturer or at authorised repair facilities only.
- **Use of other products:** Combining formwork components from different manufacturers carries certain risks. They are to be individually verified and can result in the compilation of a separate set of assembly instructions required for the installation of the equipment.
- **Use of other products:** Individual safety symbols are to be complied with. Examples:



**Safety information:** Non-compliance can lead to damage to materials or risk to the health of site personnel (also life).



**Visual check:** The intended operation is to be subject to a visual check.



**Note:** Supplementary information for safe, correct and professional execution of work activities.

- **Miscellaneous:** We reserve the right to make amendments in the course of technical development. All current country-specific laws, standards and other safety regulations are to be complied with without exception for the safe application and use of the products. They form a part of the obligations of employers and employees regarding industrial safety. This gives rise to, among other things, the responsibility of the contractor to ensure the stability of the formwork and falsework constructions as well as the structure during all stages of construction, which also includes the basic assembly, dismantling and the transport of the formwork and falsework constructions or their components. The complete construction is to be checked during and after assembly.

## 2. System overview

### 2.1 System description

Type	: Working and safety scaffold in the form of bracket-suspended scaffold with a formwork panel holder <ul style="list-style-type: none"><li>- Bracket with travelling channel and travelling device</li><li>- Bracket without travelling device, supported with stabilizers</li></ul>
Dimensions	: Working width 2.10 m, scaffold width 2.20 m
Guard rails	: Steel frame elements for handrail and knee protection, board
Boarding	: Boards 6 cm thick with edging and central coupling strip for stiffening Boarding with bracket, bolted
Permissible load	: Working or bracket level Scaffold group 4 in acc. with DIN 4420, Nominal load 3.0 kN/m <sup>2</sup> Panel height : Up to 5.30 m  Suspended platform Scaffold group 2 in acc. with DIN 4420, nominal load 1.5 kN/m <sup>2</sup>
Use	: Height above ground level max. 100 m
Anchored by	: Suspension hook fastened with anchor bolts M36 Suspension hook fastened with scaffold bolts M36 Suspension hook fastened with steel cone Tr26x5

### 2.2 Scope of application

Anchor bolt , scaffold bolt , steel cone

Unit 4.00 m :	a) Bracket central in the suspension hook	
	Height above ground level ≤ 100 m	Panel height 5.30 m
	b) Bracket eccentric in the suspension hook	
	Eccentricity max. 250 mm	
	Height above ground level ≤ 100 m	Panel height 3.00 m
Unit 6.00 m :	c) Bracket central in the suspension hook	
	Height above ground level ≤ 100 m	Panel height 4.00 m
	d) Bracket eccentric in the suspension hook	
	Eccentricity max. 200 mm	
	Height above ground level ≤ 25 m	Panel height 3.00 m

### 2.3 Schematic diagram

Use as a working scaffold  
 Scaffold group 4 in acc. with DIN 4420  
 - Panel height up to 5.30 m  
 - Brackets, hinged

Optional :  
 - Travelling device with travelling channel  
 - Lower platform

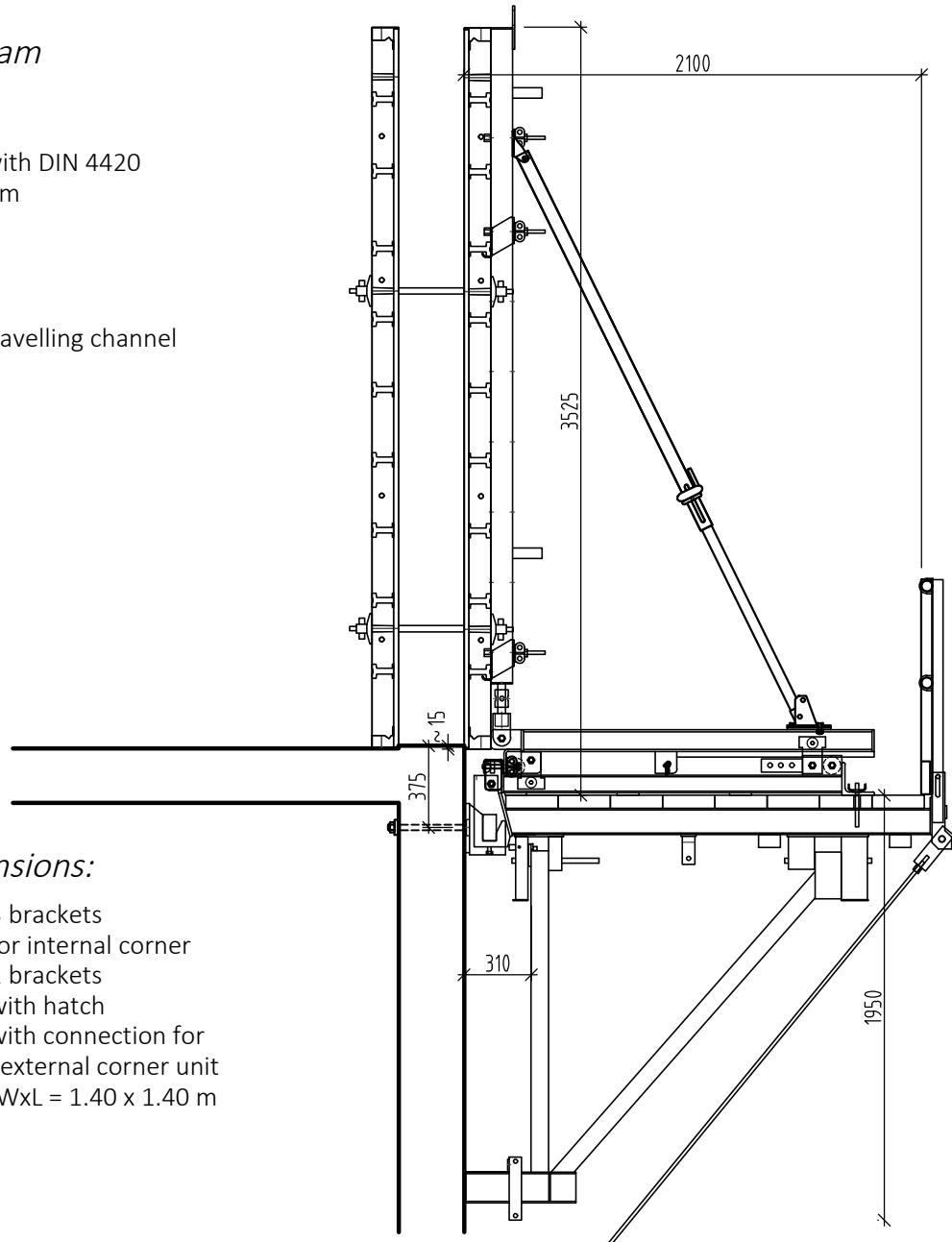

### 2.4 Standard dimensions:

- Unit WxL 2.20 x 6.00 m, 3 brackets
- Unit WxL 2.20 x 6.00 m, for internal corner
- Unit WxL 2.20 x 4.00 m, 2 brackets
- Unit WxL 2.20 x 4.00 m, with hatch
- Unit WxL 2.20 x 4.00 m, with connection for external corner unit
- External corner unit 90°, WxL = 1.40 x 1.40 m

### 2.5 Transport height and dimensions

Height : 0.60 m for 1st unit and  
 0.50 m for all further units

Plan area : 2.30 x 4.00 m  
 2.30 x 6.00 m

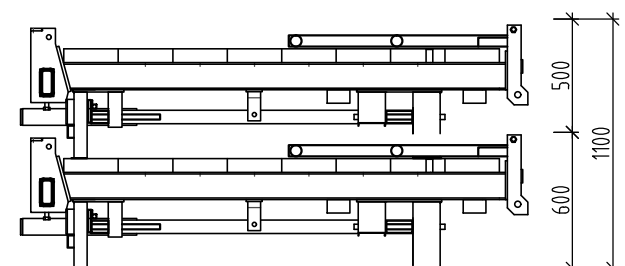
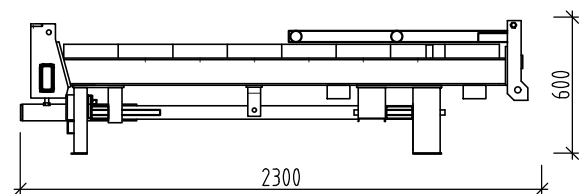

The scaffold units are supplied to site ready assembled including boards and guard rail.

### 3. Scaffolding units

*AB 300 working platform 4000 mm Part No. 557252*

Elevation

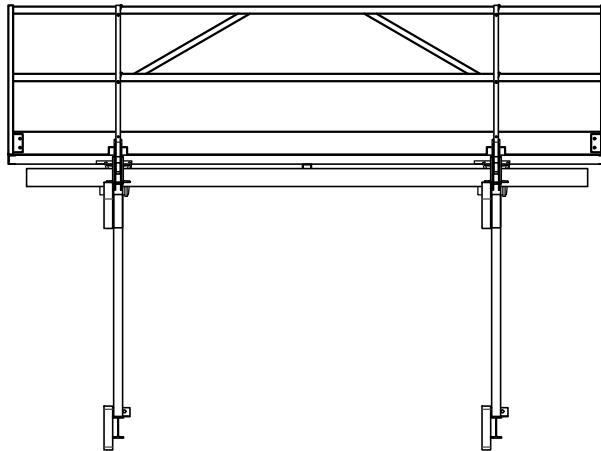

Plan view

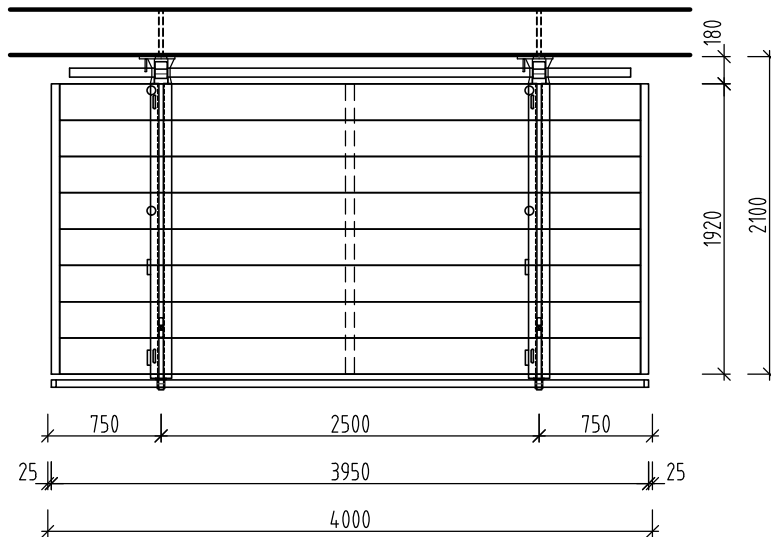

*AB 300 working platform for EC 4000 mm Part No. 557256*

Plan view

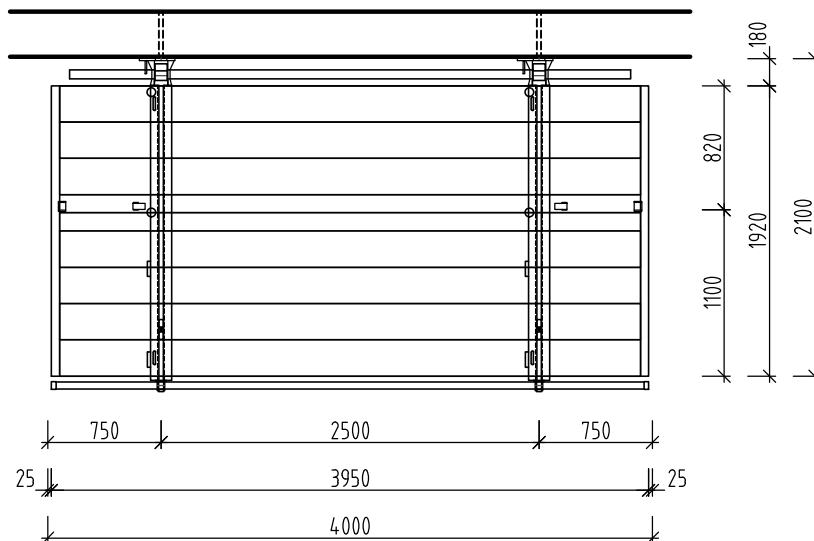

Assembly and Operating Manual  
 NOE AB300 Climbing scaffold



*AB 300 working platform 6000 mm Part No. 557250*  
 Elevation

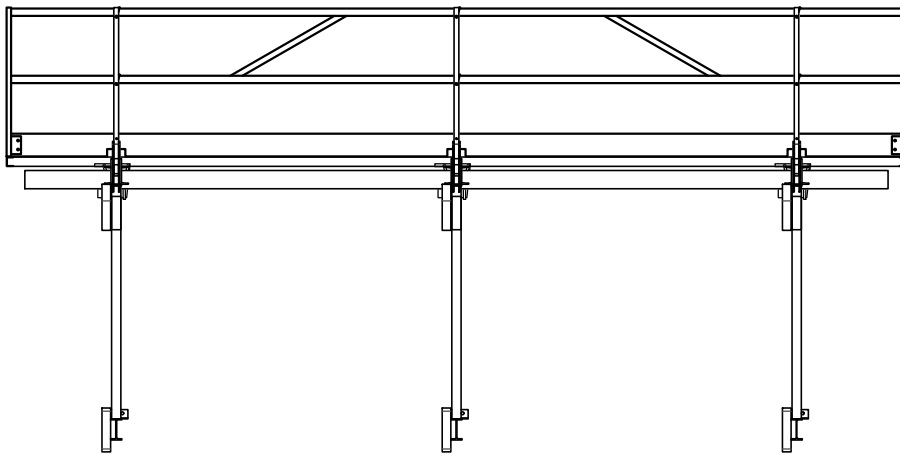

Plan view

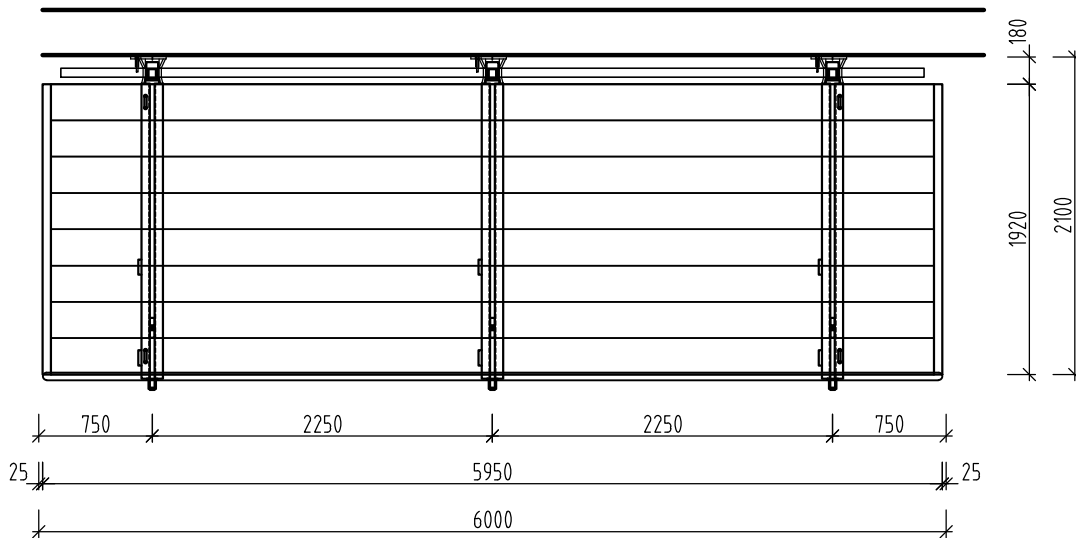

*AB 300 Working platform with hatch 4000 mm Part No. 557254*

Plan view

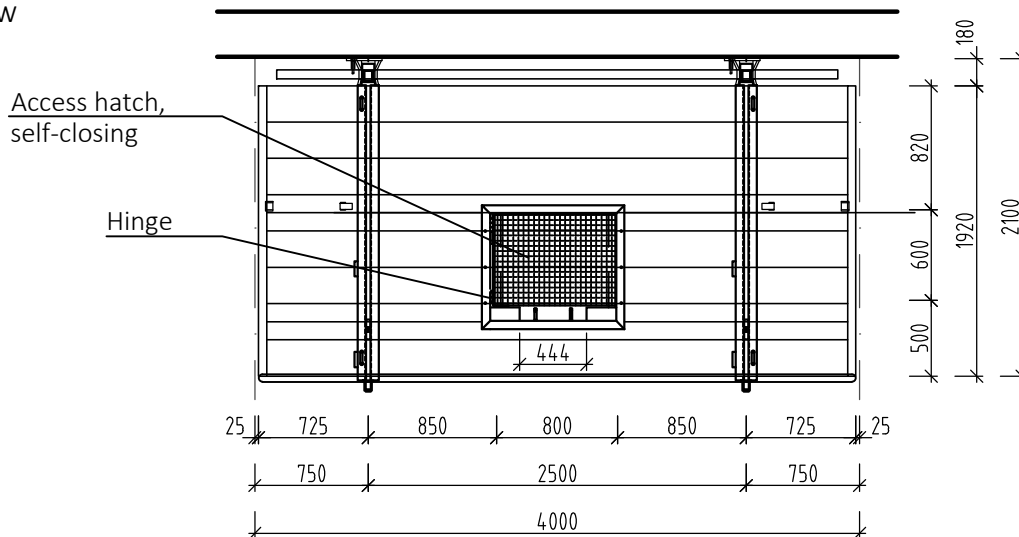

## 4. Assembly

### 4.1 Assembly process for working platforms

- Swing out guard rail (1) to open and press the post downwards into the elongated hole as far as it will go (see Detail A)
- Attach quadruple sling ropes (2) to the stirrups sunk into the boarding.

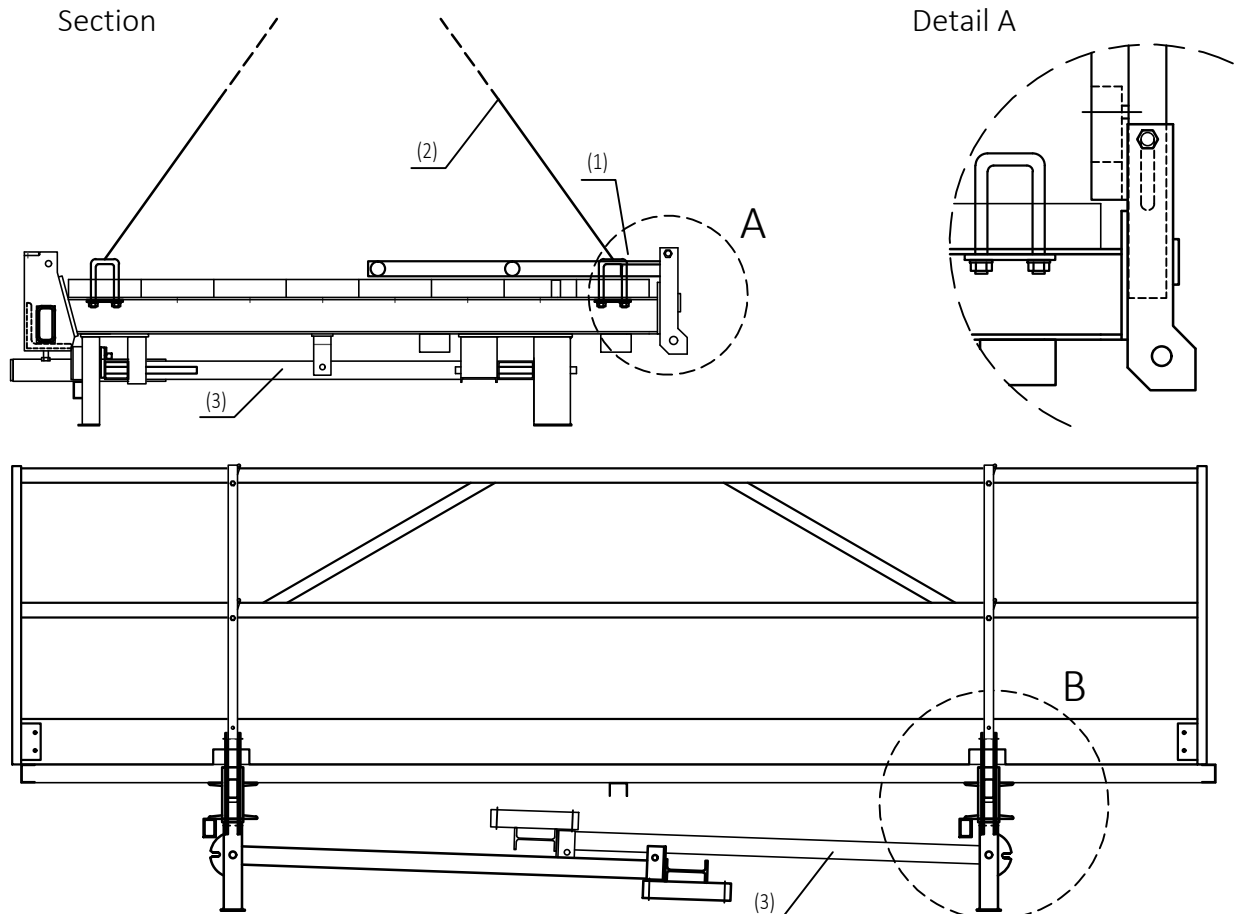

- The bracket legs (3) are folded in for transport and locked in place with the safety lever (4) (see Detail B and Elevation C)

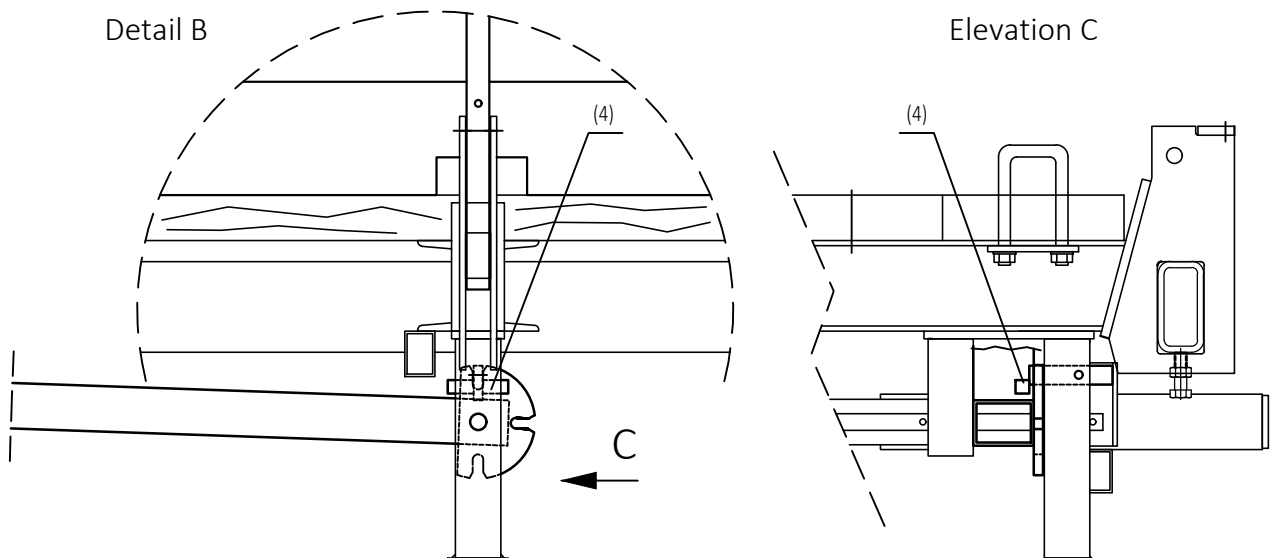



- Lift the climbing scaffold and hold the brackets when folded downwards, then lift the safety lever (4) to unlock the bracket legs (3) (see Elevation E)

- By lifting the platform, the platform legs swing into the vertical position and the safety lever (4) locks itself in place automatically.

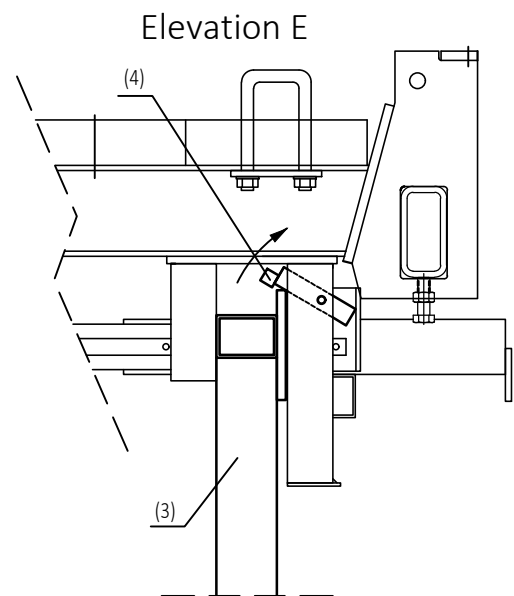
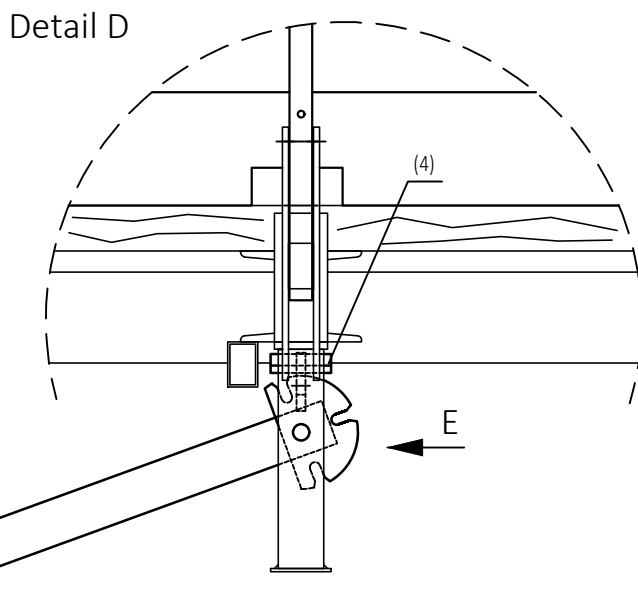
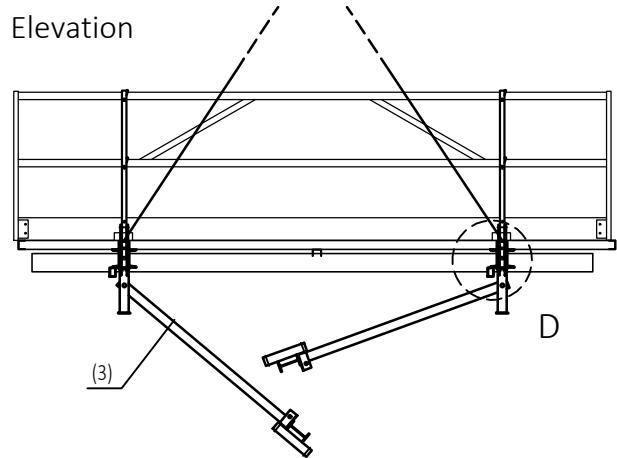

- Attach the scaffold unit by the support tube (5) to the suspension hooks (6), which lock themselves automatically to prevent detachment (see 'Suspending the platform')

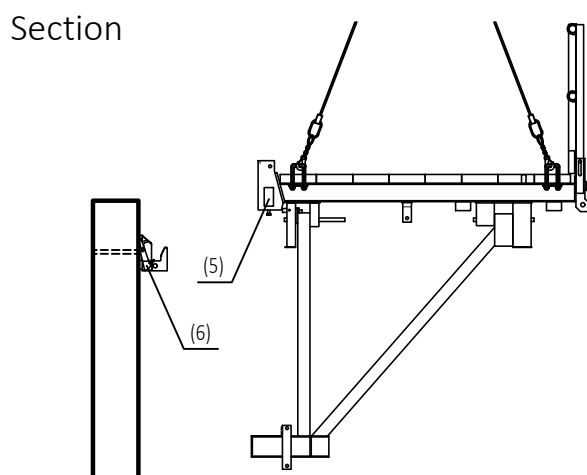

4.2 Working platform with suspended lower platform

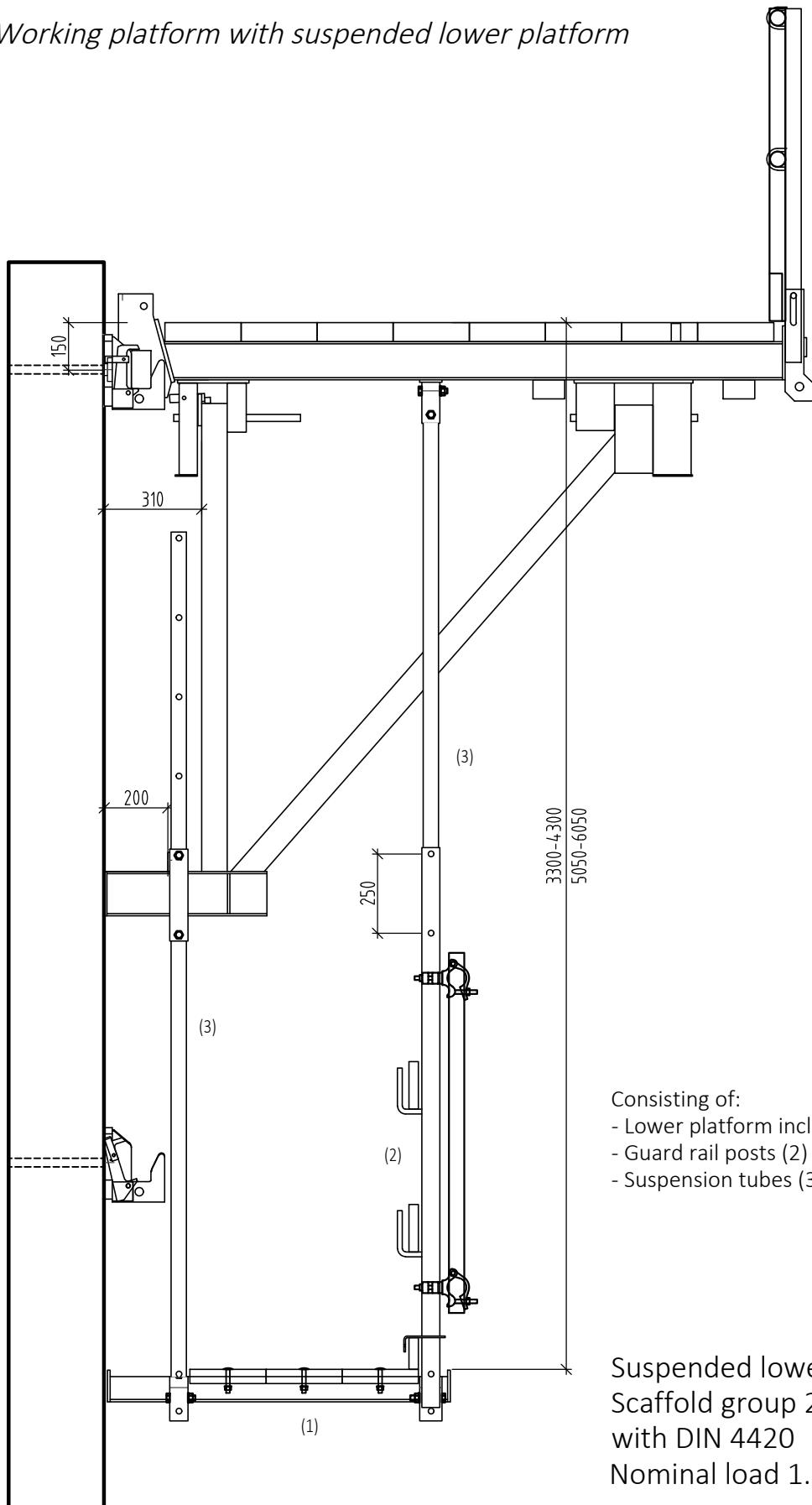

- Consisting of:
- Lower platform including Boarding (1)
  - Guard rail posts (2)
  - Suspension tubes (3)

Suspended lower platform  
 Scaffold group 2 in acc.  
 with DIN 4420  
 Nominal load 1.50 kN/m<sup>2</sup>

### 4.3 Tables of parts for suspended lower platform

Individual parts for suspended lower platform	Part No.	Unit 4.00 m	Unit 6.00 m	Unit 4.00 m with ladder exit
Suspension tube for platform spacing: 3.30 m up to 4.30 m or 5.05 m up to 6.05 m	557214 557215	4	6	8
Only when used with suspension tube Part No. 557215				
Scaffold tube 1.50 m	501500	2	2	2
Coupler 48x48	510300	2	4	4
Lower platform 4.00 m	557258	1	-	1
6.00 m	557260	-	1	-
Guard rail	557221	2	3	2
M16x 80 N+W for suspension tube	see 9	16	24	36
M16x100 N+W for lower platform	see 9	4	6	4
Scaffold tube 1.50 m	501500	-	-	6
3.00 m	503000	1	-	-
5.00 m	505000	-	1	-
Coupler 48x60	510600	2	2	12
Guard rail board 4.00 m	557224	2	-	-
6.00 m	557225	-	2	-
Board 4.00 m	557226	1	-	1
6.00 m	557227	-	1	-
Ladder entry, consisting of floor and side parts	557274	-	-	1
Ladder Ladder clamp plate Back-propping		-	-	see table below

### Ladders and back-propping

Platform spacing in mm	Ladder 2750 mm Part No. 126140	Ladder 1000 mm Part No. 126150	Ladder clamp plate Part No. on request	Back-propping 2750 Part No. 126191	Back-propping 1000 Part No. 126192	Back-propping 500 Part No. 126193
3300 - 3550	2	-	2	-	1	-
3800 - 4050	2	-	2	-	1	1
4300	2	1	-	-	2	-
5050 - 5300	3	-	4	1	-	-
5550 - 5800	3	-	4	1	-	1
6050	3	-	4	1	1	-

#### 4.4 Assembly process lower platform

➔ Assembly of the AB300 with suspended lower platform must be carried out on a level surface

The suspended lower platform 6000 is assembled in accordance with the following instructions but using an increased number of parts.

- 1 Swing out and engage guard rail (a). Attach the crane's lifting tackle to the sunken stirrups nearest the guard rail and take the crane ropes up through the guard rail (see Fig. 1).

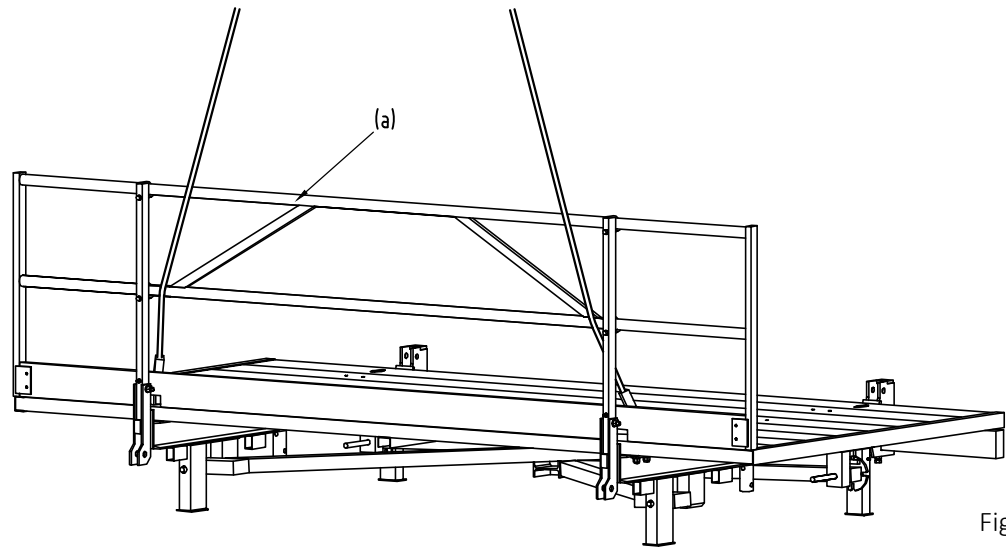
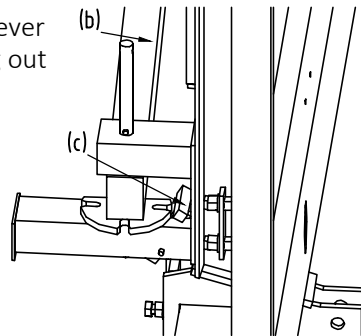

Fig. 1

- 2 Lift the working platform slowly into the vertical and swing out the brackets (b). To do this, the safety lever (c) must be first unlocked and then the brackets swung out until the safety lever snaps into place. After swinging the brackets out, check that the safety lever has re-engaged (see Fig. 2).

Unlock the safety lever (c) before swinging out the brackets (b).



After swinging out the brackets ensure that the safety lever has re-engaged.

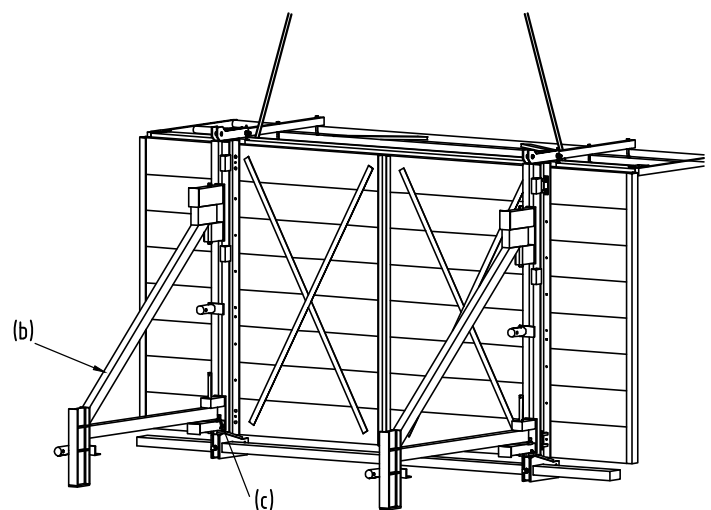
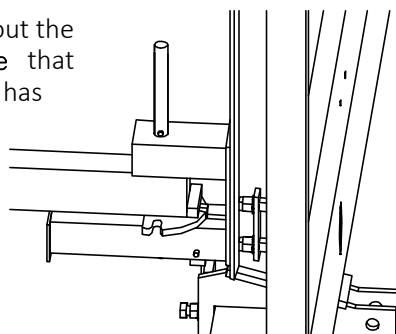

Fig. 2

- 3 Set the working platform down and fasten the 2 push-pull braces (d) in place by screwing the wing head bolts (e) [Part No. 135009] into the threaded sockets in the platform boarding and anchor the braces to the substrate to resist tension and compression forces. Only then can the crane rope be released (see Fig. 3).

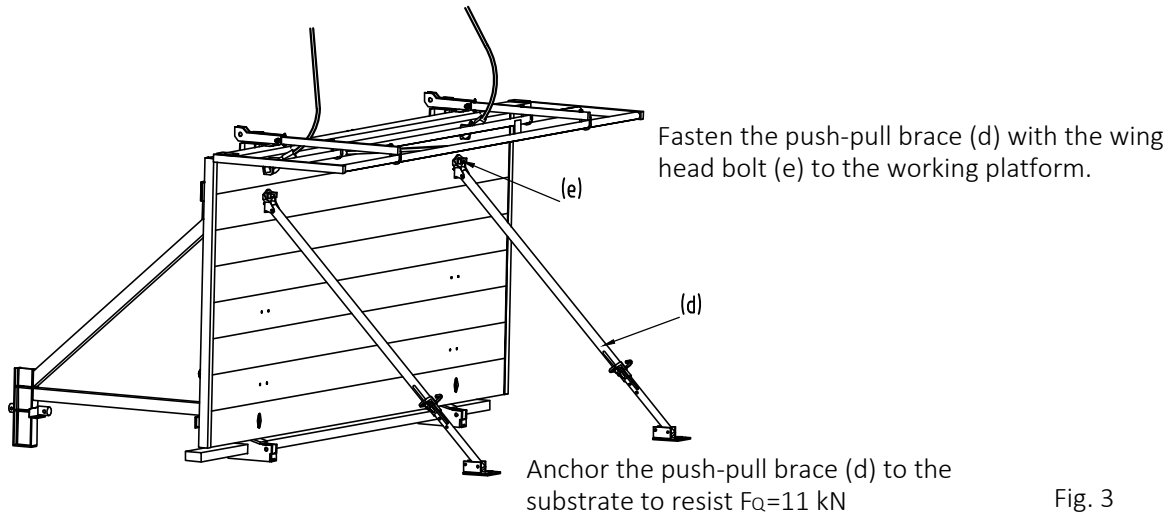

Fig. 3

- 4 Fasten suspension tube (f), hole spacing 25 cm, to the working platform:
  - 2.75 m long [Part No. 557214] for a platform spacing of approx. 3.30-4.30 m
  - 4.50 m long [Part No. 557215] for a platform spacing of approx. 5.05-6.05 m
 Fasten tube to brackets each with 2 bolts M16x80 (g), paying attention to the hole spacing. Push the guard rail for lower platform (h) [Part No. 557221] over the top suspension tube but do not yet screw it in place (see Fig. 4).

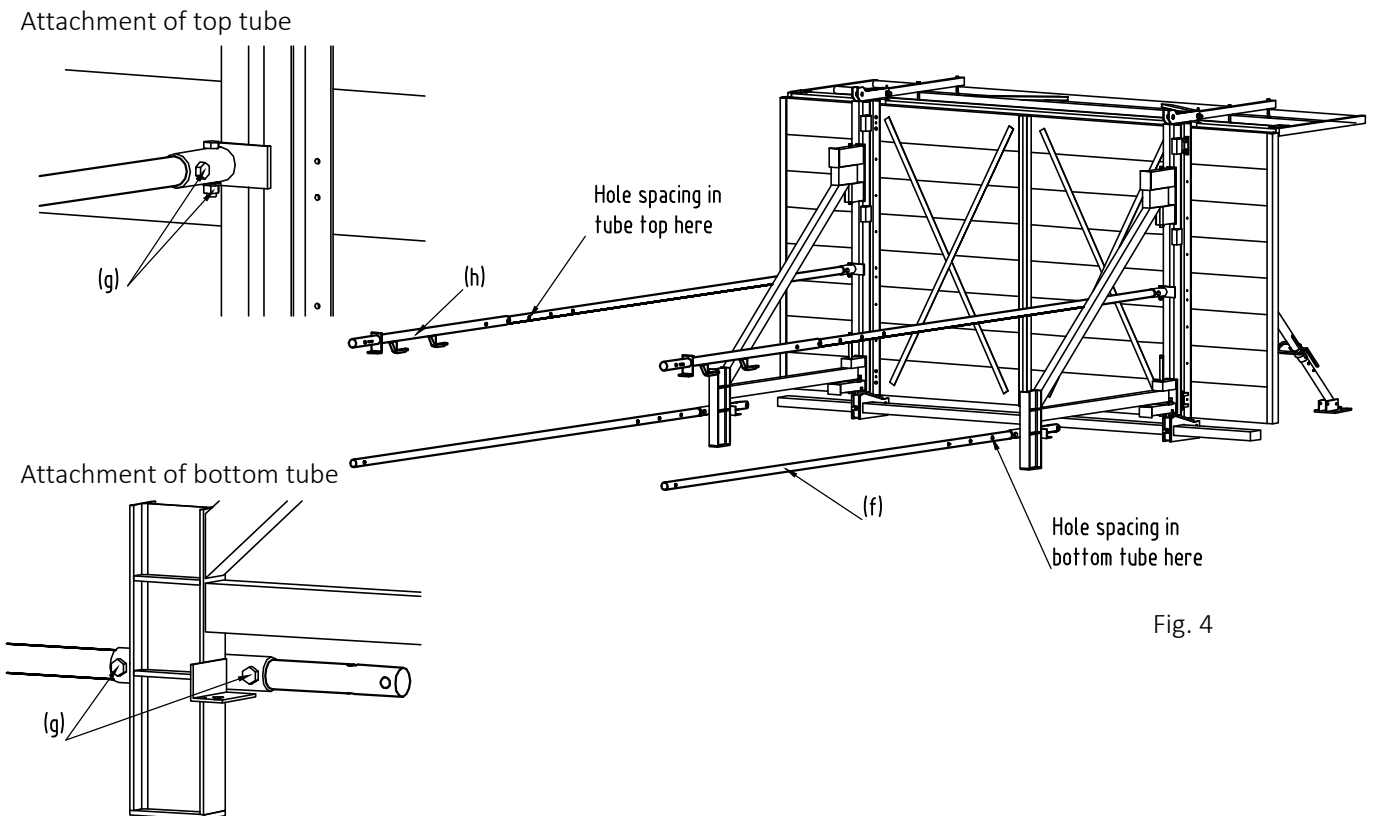
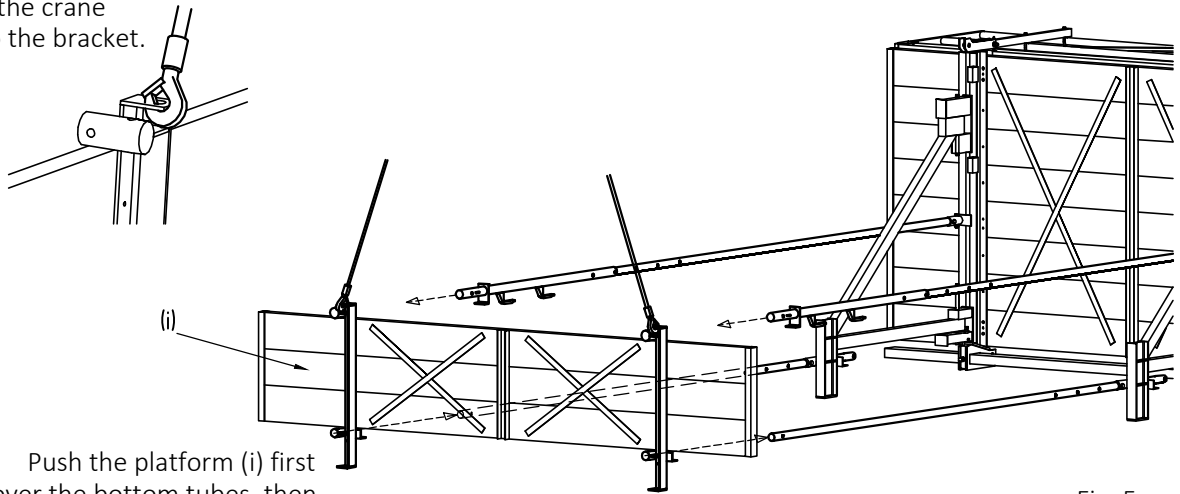

Fig. 4

- 5 Attach lower platform (i) [Part No. 557258] to the crane ropes and lift it slightly. Push the lower platform first over the bottom tubes, then push the guard rail into the top sleeves of the platform (see Fig. 5).

Attach the crane hook to the bracket.



Push the platform (i) first over the bottom tubes, then push in the guard rail.

Fig. 5

- 6 Fasten guard rails (h) to the top tubes and the bottom tubes on the platform each with 2 bolts M16x80 (g).  
Fasten guard rails (h) to the platform each with 2 bolts M16x100 (k) (see Fig. 6).

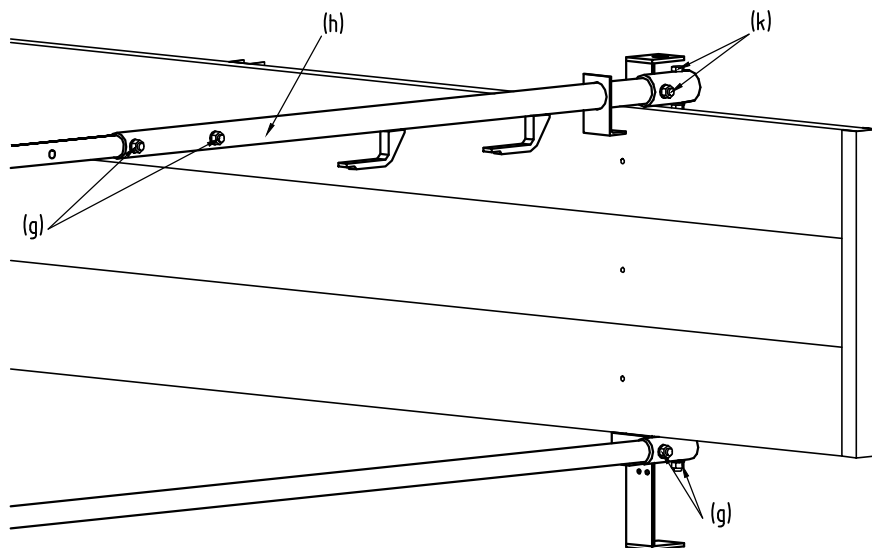

Fig. 6

- 7 Insert guard rail board (l) [Part No. 557224] and board (m) [Part No. 557226] and attach with nails. Fasten diagonal scaffold tube [Part No. 503000] with 2 No. swivel couplers 48x60 (o) [Part No. 510600] to the guard rails (h) (see Fig. 7).

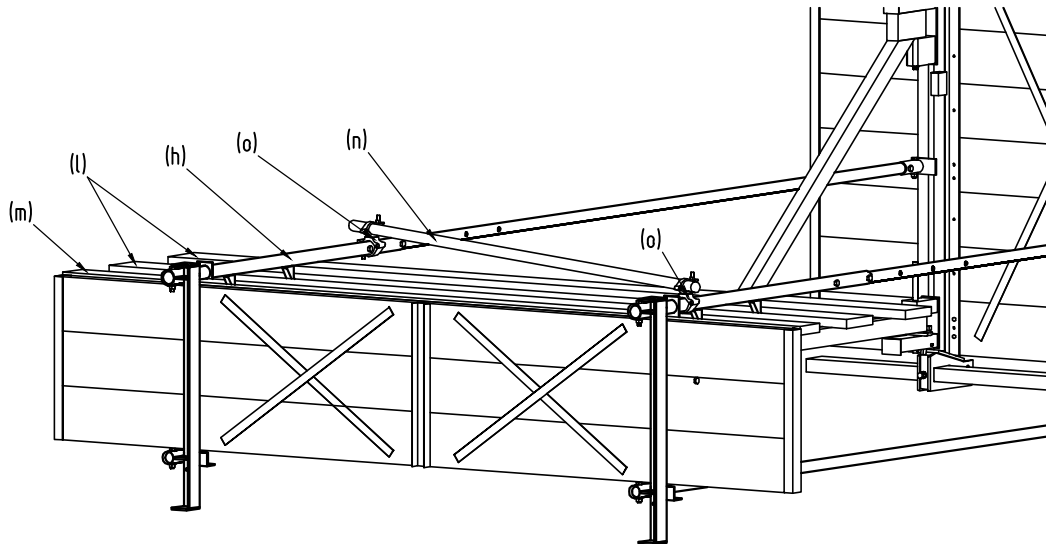

Fig. 7

- 8 Attach the quadruple crane ropes (p) to the stirrups sunk into the boarding. Release the stabilizers from the substrate and from the working platform and then slowly lift the working platform with suspended lower platform (see Fig. 8).

If long scaffold tubes are used, then an additional 2 diagonal scaffold tubes (q) [Part No. 501500] each with 2 No. swivel couplers 48x48 (r) [Part No. 510300] must be attached to the suspension tubes.

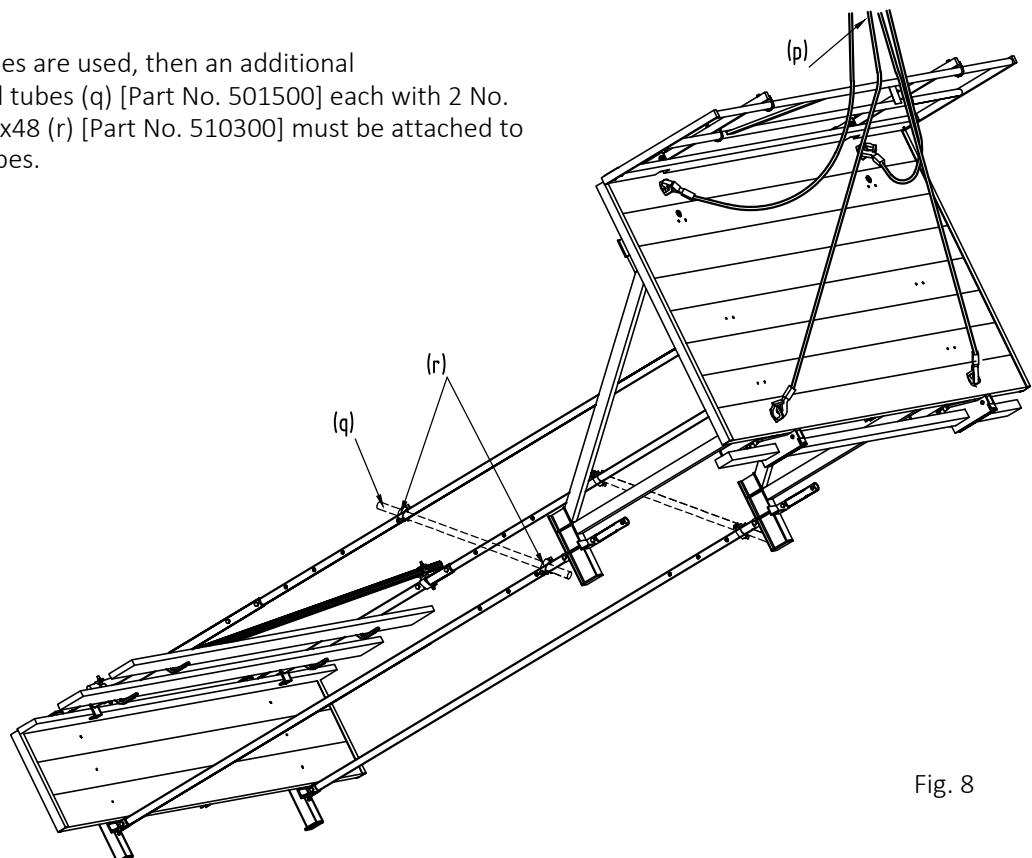

Fig. 8

#### 4.5 Assembly process for unit with hatch and ladder ascent

➔ The working platform is assembled in accordance with sections 1-6. Then as described below.

- 9 4 No. Fasten the suspension tubes (l) for ladder ascent to the working platform:
- 2.75 m long [Part No. 557214] for a platform spacing of approx. 3.30-4.30 m
  - 4.50 m long [Part No. 557215] for a platform spacing of approx. 5.05-6.05 m
- Fasten tubes to brackets each with 2 bolts M16x80 (g), paying attention to the hole spacing (see Fig. 9).

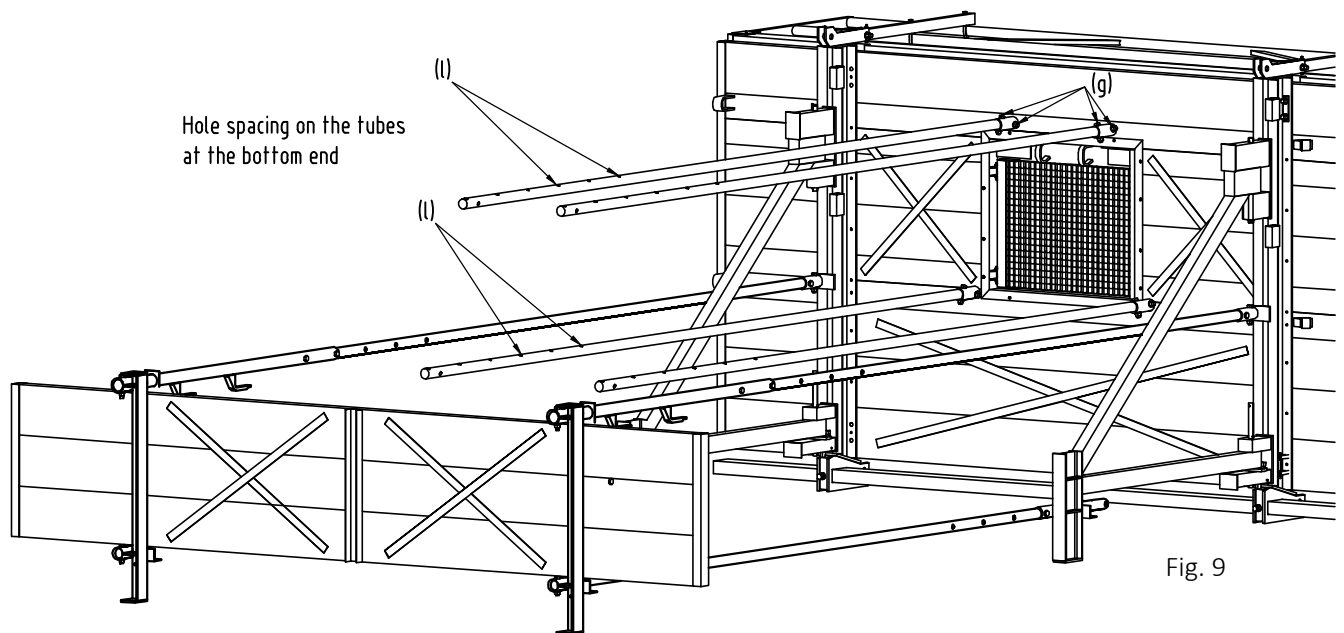

Fig. 9

- 10 Push the side parts (m) of the ladder exit over the suspension tube and fasten each with 2 bolts M16x80 (g). The hole centres of the tubes correspond with those of the suspension tube for the lower platform (see Fig. 10).

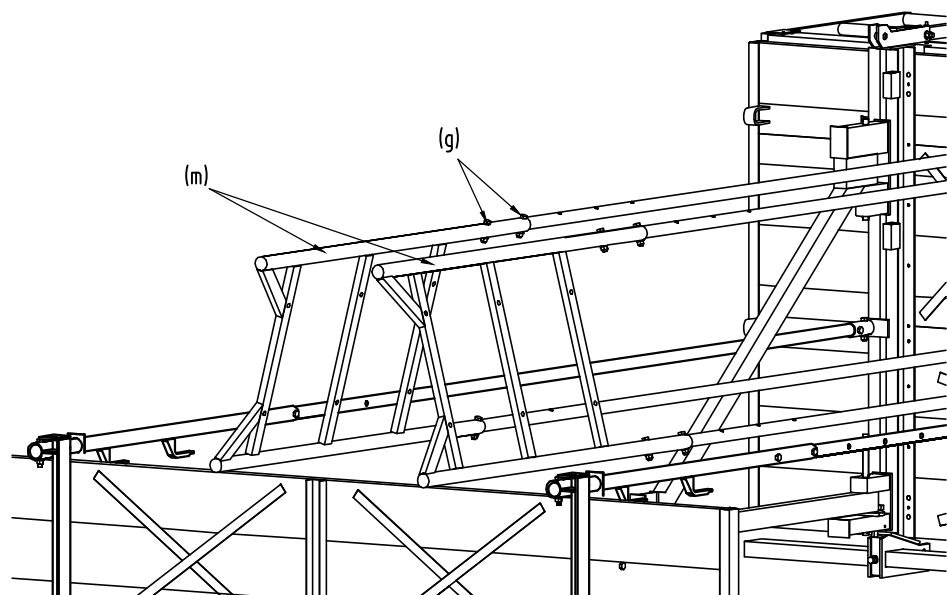

Fig. 10



- 11 Fasten board (o) to the lower platform. Bolt the floor (n) of the ladder ascent to the side parts with 4 bolts M16x80 (g). The floor of the ladder ascent must be above the floor of the lower platform (see Fig. 11).

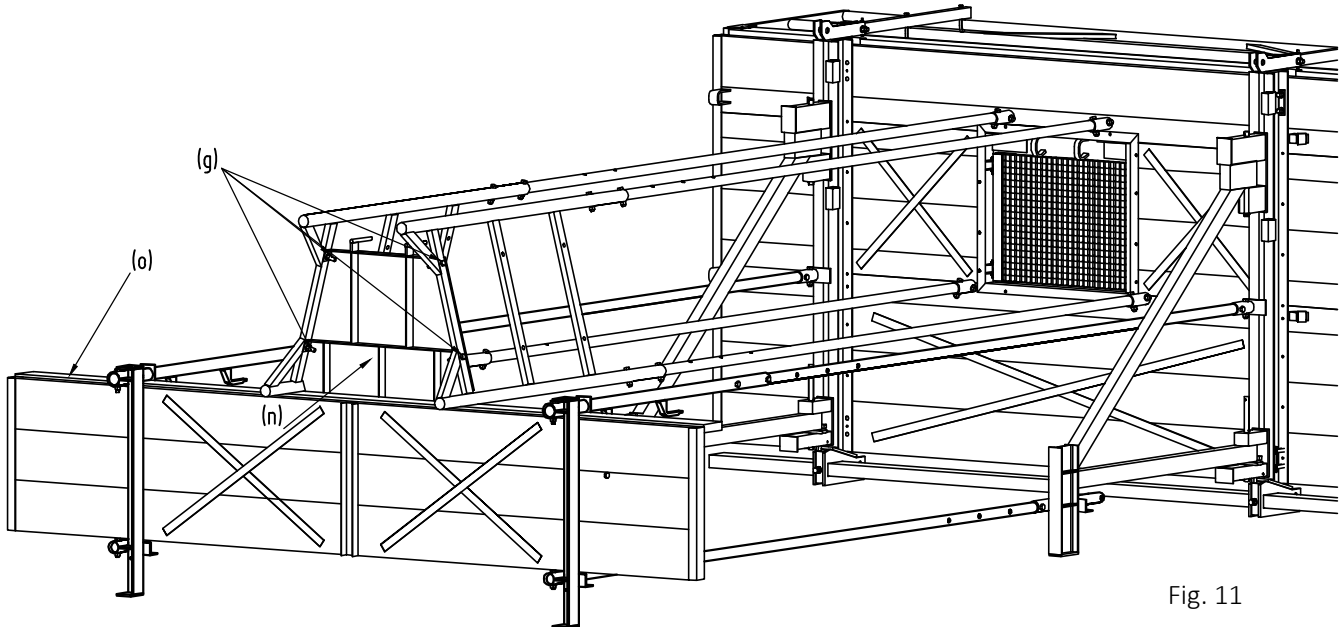

Fig. 11

- 12 Fasten scaffold tubes 1500 mm long (p) [Part No. 501500] to the suspension tubes of the lower platform and the ladder ascent each with 2 swivel couplers 60x48 (q) [Part No. 510600]. Attach 4 tubes horizontally as guard rail, 2 tubes diagonally as stiffeners (see Fig. 12).

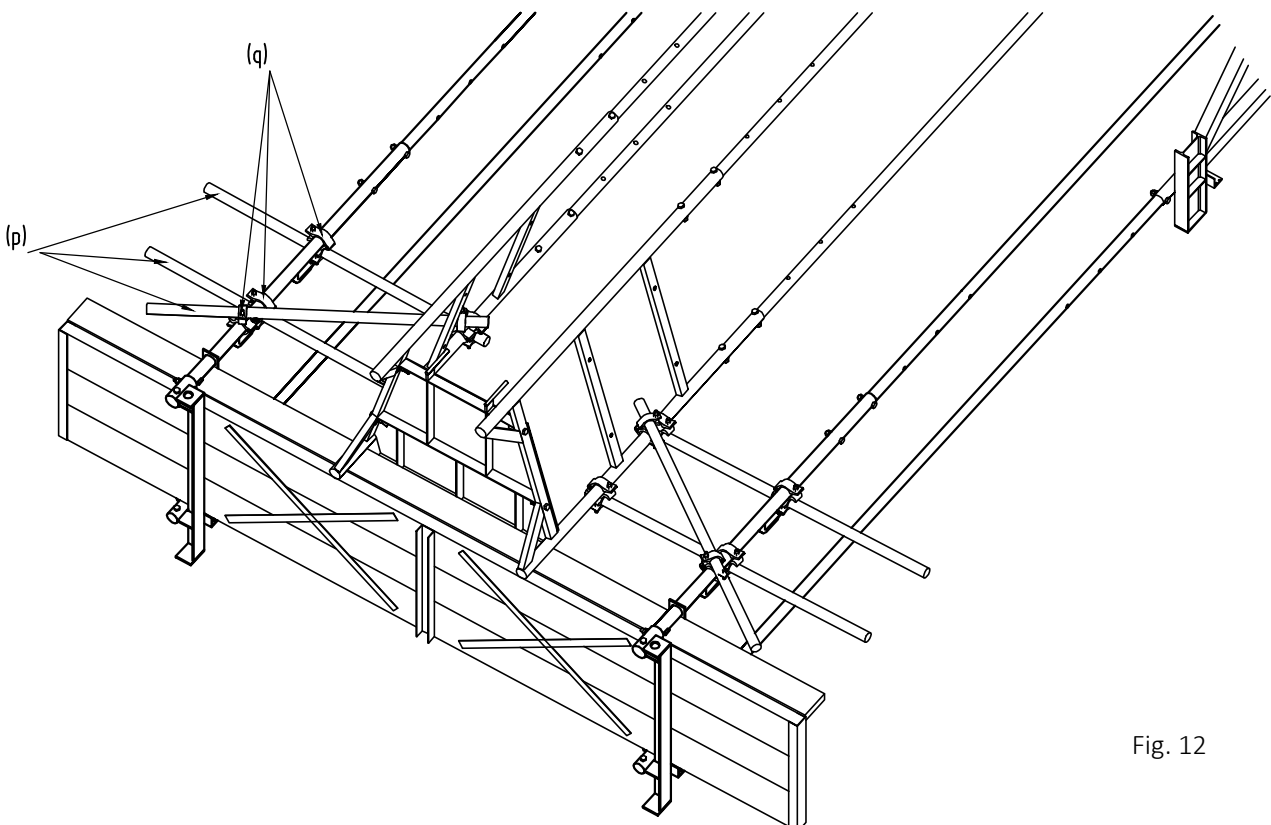

Fig. 12

- 13 Connect ladders (r) with ladder clamp plates (s) positioned diagonally. To do this, pull out the wedge, fit the ladder clamp plates over 2 rungs and hammer in the wedge. The ladders must overlap a min. 2 rungs or 0.5 m (see Fig. 13).

2 or 3 ladders may be required, depending on the height. The total length of the ladder is at least the distance from the top of the boarding of the upper platform to the top of the boarding of the lower platform + 1.00 m.

### NOE ladders

Part No.	Description
126140	Ladder 2750 mm
126150	Ladder 1000 mm

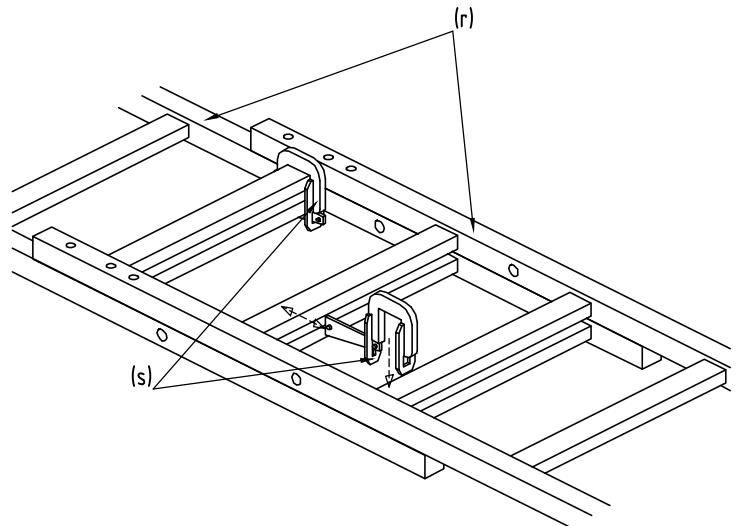

Fig. 13

- 14 Suspend the ladder (r) from the hook (s) of the platform at the top and in between use the pins (t) and the boarding on the ladder ascent (see Fig. 14).

Choose a length for the back-propping (u) such that the distance H from the top of the boarding of the ladder ascent to the underside of the back-propping is between approx. 1.90 and 2.15 m.

### NOE back-propping

Part No.	Description
126191	Back-propping 2750 mm
126192	Back-propping 1000 mm
126193	Back-propping 500 mm

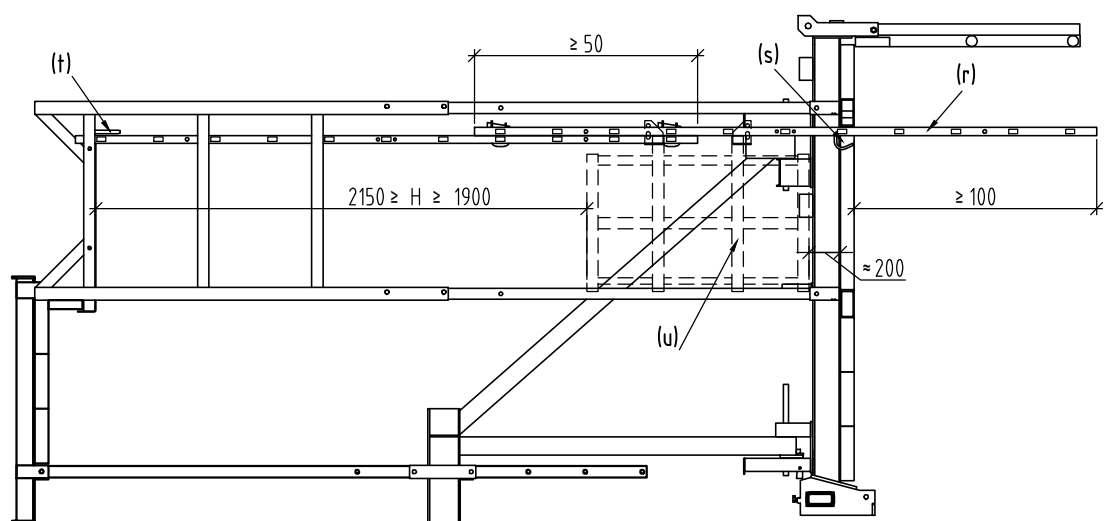
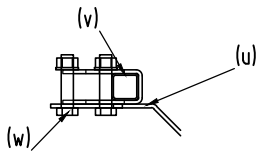
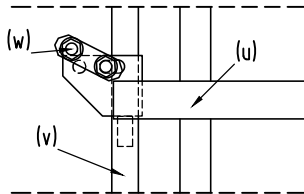

Fig. 14

- 15 Push the back-propping (u) over the ladder stiles (v) and insert the connection channel (w) in such a way that the ladder is firmly fixed. The distance between the underside of the platform and top of the back-propping must not exceed a maximum of 200 mm (see Fig. 15).

Ladder inner



Two ladders

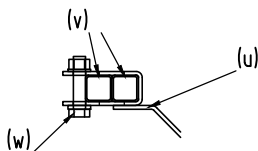
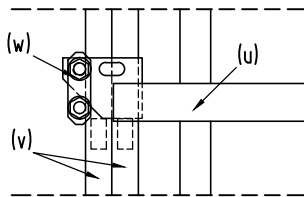

Ladder outer

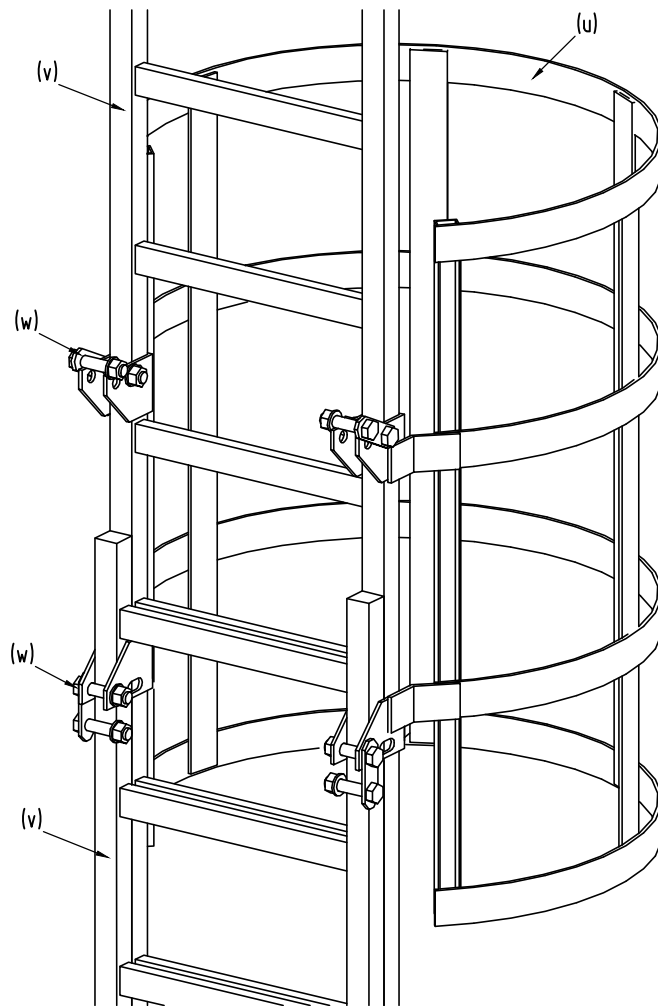
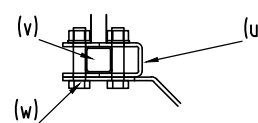
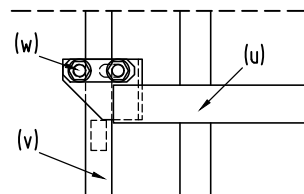

Fig. 15

- 16 Attach the quadruple crane ropes (p) to the stirrups sunk into the boarding.  
Release the stabilizers from the substrate and from the working platform and then slowly lift the working platform with suspended lower platform (see Fig. 16).

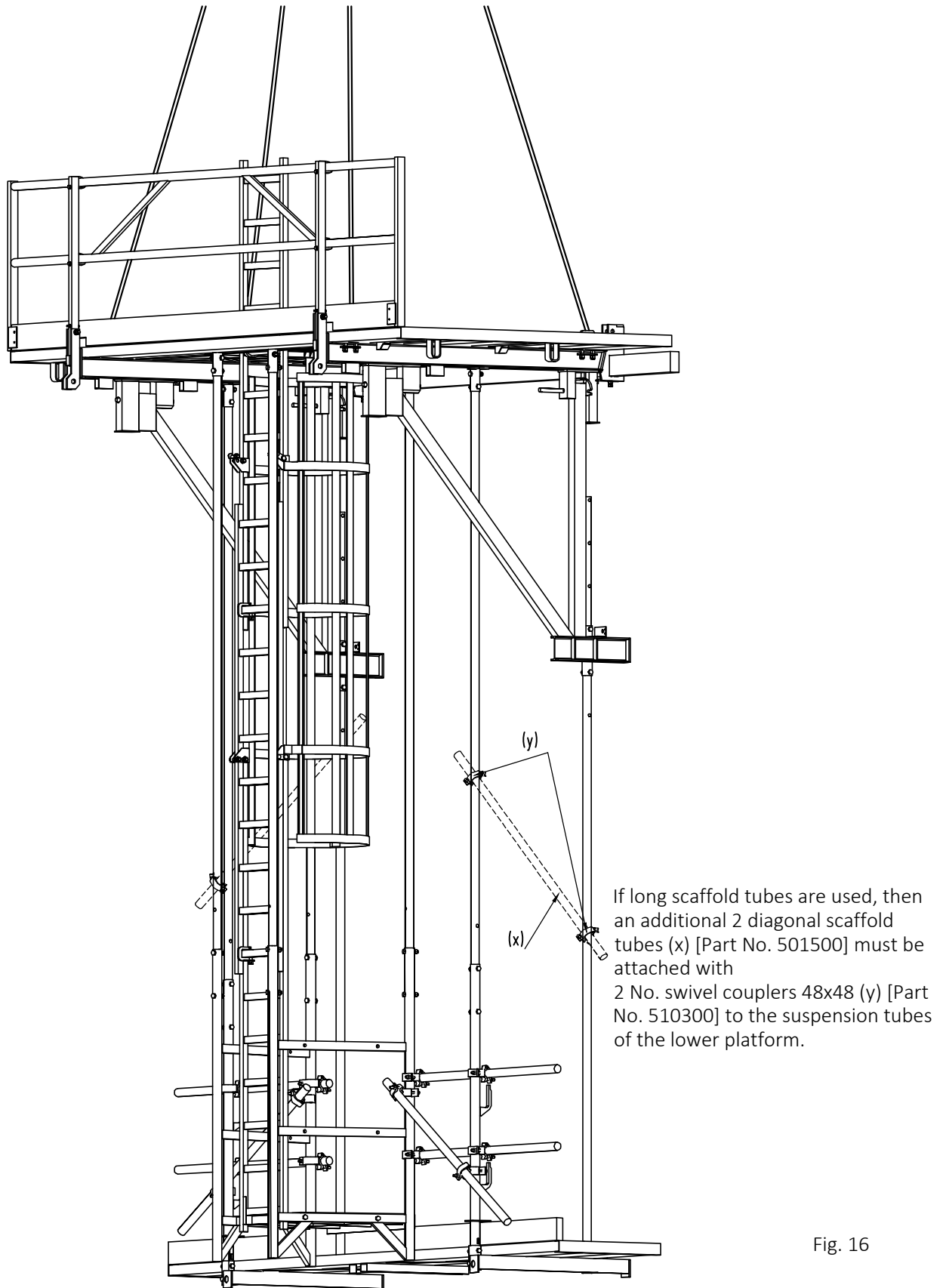
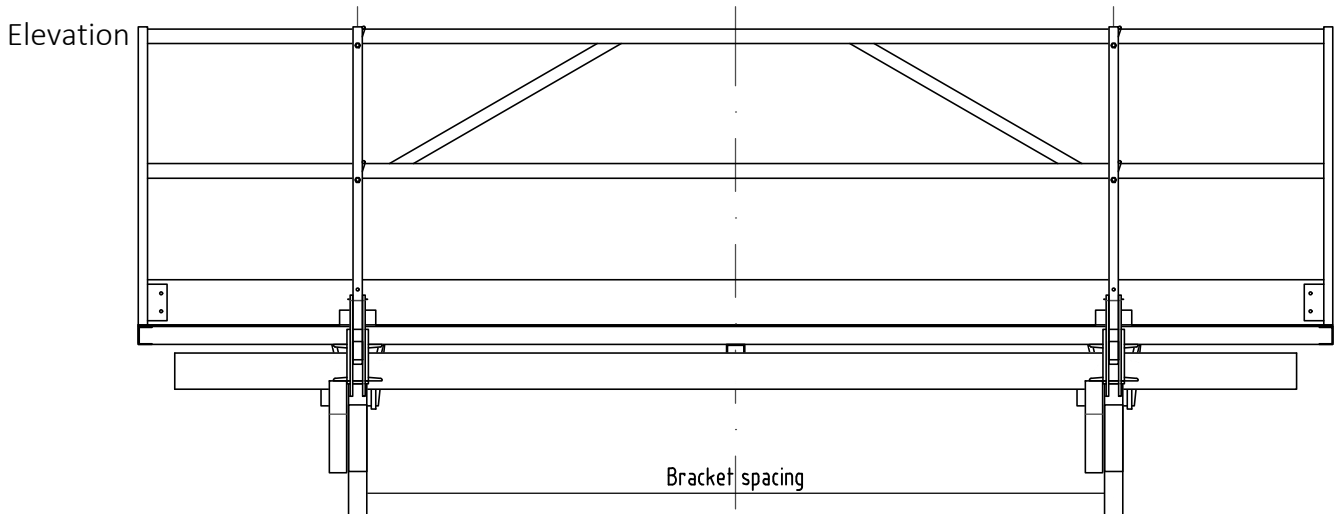

Fig. 16

## 5. Scaffold suspension

### 5.1 Available play when installing the suspension hooks



#### 1. Central hook arrangement



Elevation suspension hooks



#### 2. Eccentric hook arrangement

e.g. with recesses (combination with other hook arrangements possible)

a) To the outside

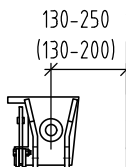

130-250  
(130-200)

Values in brackets for unit 6.00 m

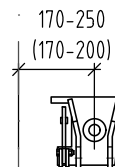

170-250  
(170-200)

b) To the inside

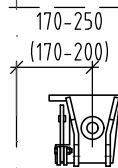

170-250  
(170-200)

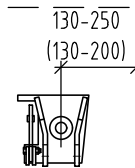

130-250  
(130-200)

c) To the right

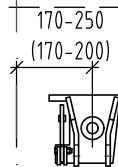

170-250  
(170-200)

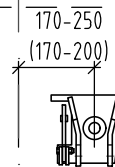

170-250  
(170-200)

d) To the left

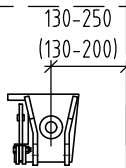

130-250  
(130-200)

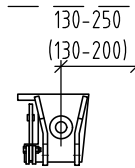

130-250  
(130-200)

4.00 m unit : Max. distance with eccentric suspension 250 mm  
 Unit 6.00 m : Max. distance with eccentric suspension 200 mm  
 Eccentric hook arrangement with unit 6.00 m similar to unit 4.00 m

5.2 Details of central and eccentric hook arrangement

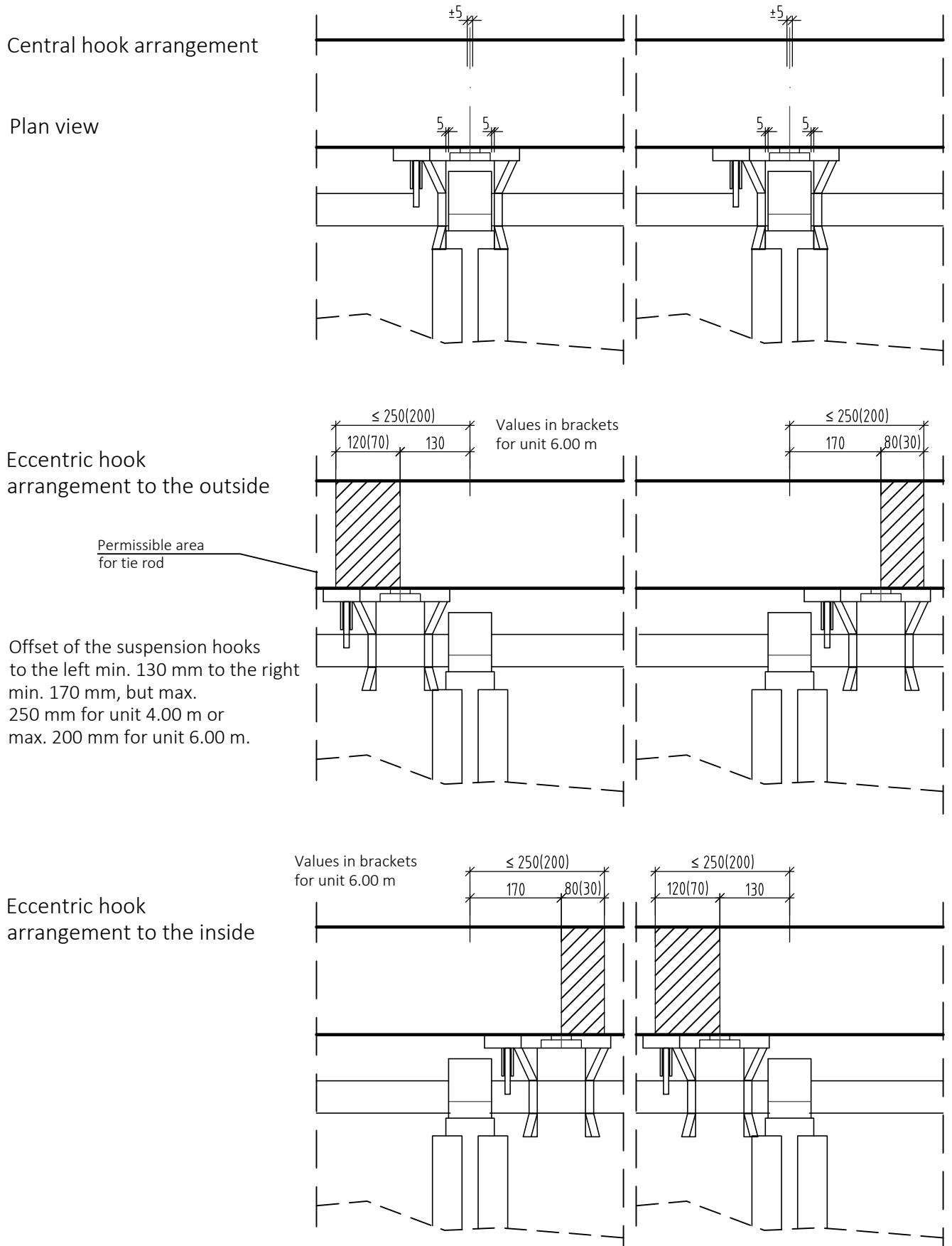

5.3 Fastening the suspension hooks with screw anchor M 36x430

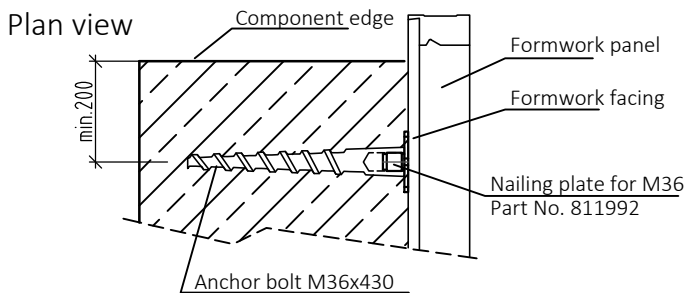
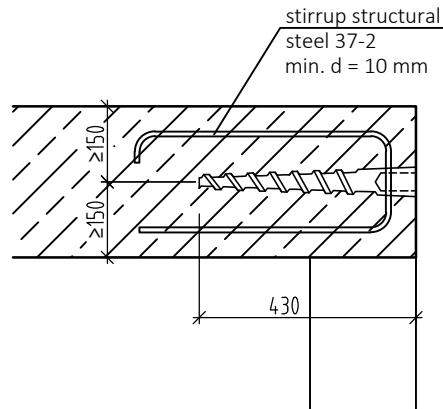
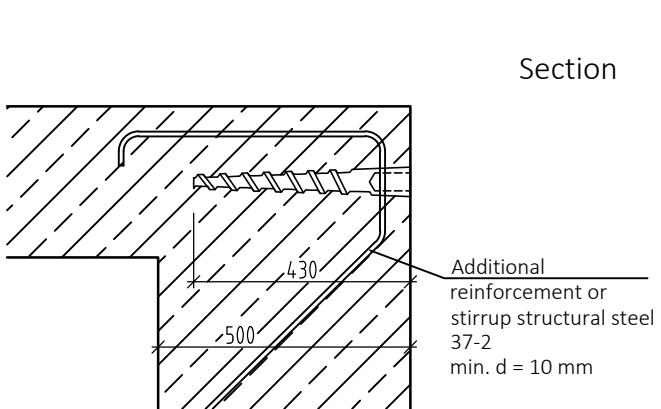

Installing the anchor point:

Fastening with nailing plate

- Nail nailing plate for M36 to the formwork facing
- Lightly oil the screw anchor and bolt on to the nail plate.
- When stripping the formwork, the nail plate remains on the screw anchor and can then be screwed out using a square (13 mm or 1/2 inch) socket.

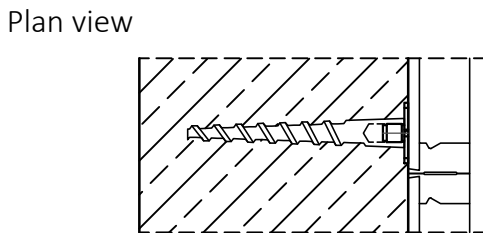

Alternative screw anchor fastening

- Drill formwork facing (Ø38 mm)
- Lightly oil screw anchors M36x430 and fasten with hex-head bolt M36x60
- Use tube spanner SW55 to tighten
- Remove hex-head bolt M36x60 before stripping formwork

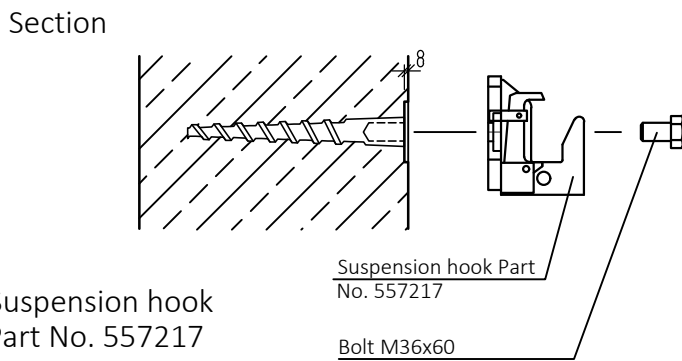

Suspension hook fastening

- Strip formwork
- Fasten suspension hook for screw anchor M36x430 with hex-head bolt M36x60 in screw anchor M36x430 using tube spanner SW55
- After use, screw out screw anchor M36x430 using spanner for screw anchor for reuse

Scope of application see system description.  
Minimum concrete strength 15 N/mm<sup>2</sup> (B15)

Suspension hook Part No. 557217

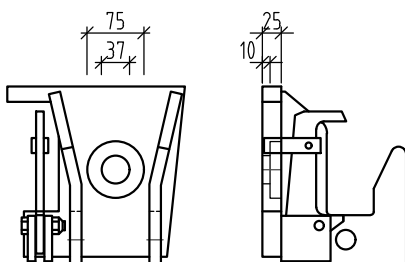

Required parts :	Part No.
Nailing plate for M36	811992
Screw anchor M36x430	811900
Hex-head bolt M36x60	318200
Suspension hook	557217
Spanner for screw anchor M36x430	811910
Tube spanner SW55	390355

### 5.4 Fastening the suspension hook with scaffold bolt M36

Section

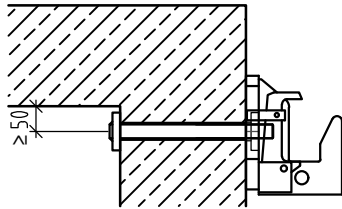

#### Installing the anchor point:

For scaffold bolt

- Nail plug Ø42 mm to the formwork facing
- Push cut-to-length sleeve Ø42 onto the plug
- After stripping, the scaffold bolt can be fed through the sleeve.

Plan view

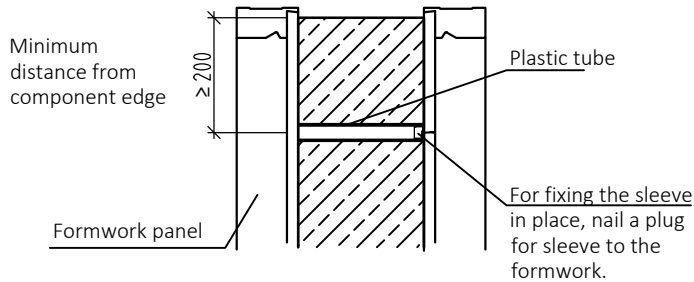

#### Scaffold bolt and hook installation

- Push through scaffold bolt with plate from rear, push the suspension hook on to the bolt, and tighten M36 nut with tube spanner SW 55 from the scaffold side.
- After use remove M36 nut, suspension hook and scaffold bolt

Section

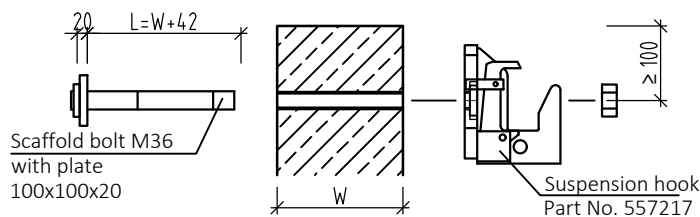

#### Suspension hook Part No. 557217

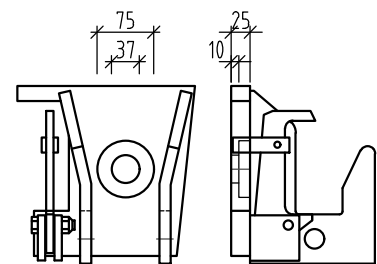

**Attention:** The scaffold bolt must be releasable only from the scaffold side.

Scaffold bolts M36

Wall thickness W	Part No.	Length L	Weight kg
150	312610	192	3,3
180	312620	222	3,6
200	312630	242	3,7
220	312640	262	3,8
240	312650	282	4,0
250	312660	292	4,1
300	312670	342	4,5
350	312680	392	4,9

Required parts :	Part No.
Scaffold bolt M36	see table
Suspension hook	557217
Tube spanner SW 50/55	390355
Sleeve round D=42 mm, 3000 mm	692012
Plug SFL 45 black, 250 No.	693910

#### Detail plan view suspension hook

Incorrect

Correct

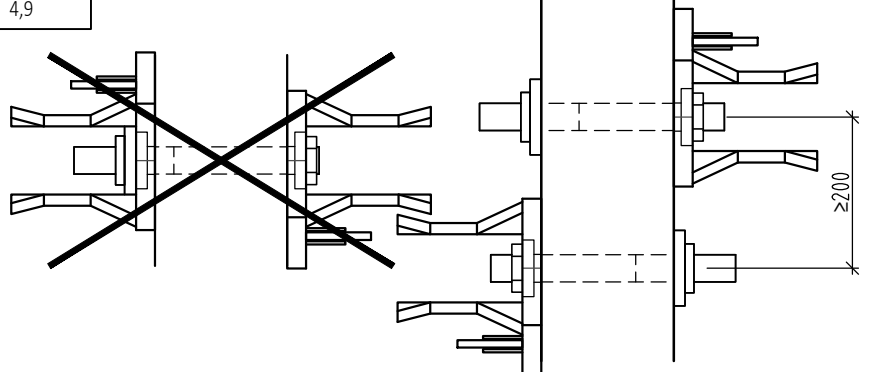

Scope of application see system description.

Minimum concrete strength 25 N/mm<sup>2</sup>



### 5.5 Fastening the suspension hook with removable tie cone

#### 1.) Fasten tie cone to formwork panel

Plan view

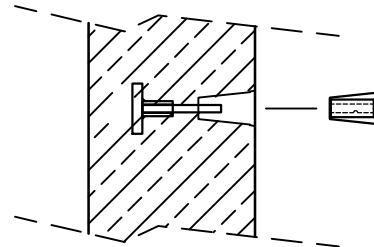
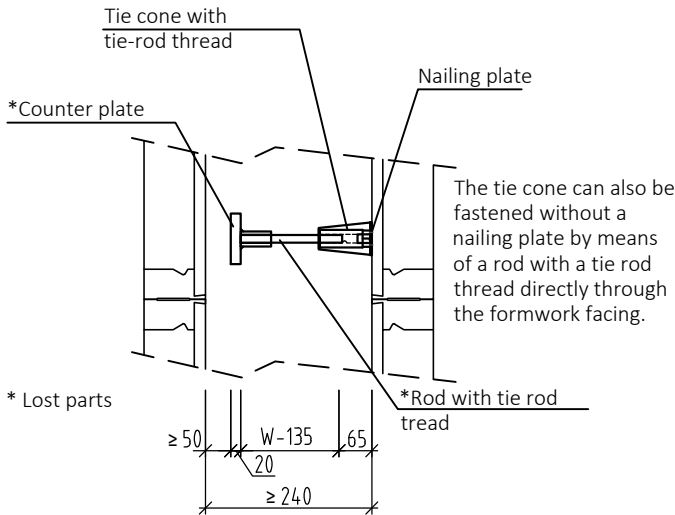

#### Installing the anchor point:

- Fasten nailing plate to the formwork facing
- Screw in the tie-rod-threaded rod as far as it will go into the counter plate and into the tie cone
- Screw the tie cone with tie rod and counter plate into the nailing plate
- After stripping the formwork, screw out the nailing plate and tie cone with a spanner
- Screw in the steel cone for use as a removable cone with the spanner for steel cone
- Fasten suspension hook with bolt Tr26 using spanner SW 55 into the steel cone
- After use, unscrew suspension hook and steel cone and bolt Tr26x5 for reuse

Minimum distance to component edges 200 mm, if nec. fix additional reinforcement.  
The tie-rod-threaded rod must be fully screwed into the tie cone (as far as it will go)!

#### 3.) Installing the removable cone

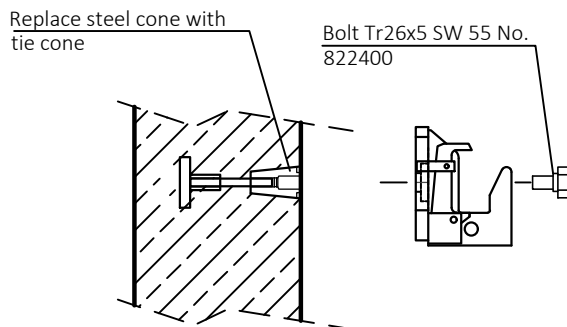

#### 4.) Suspension hook in the removable cone

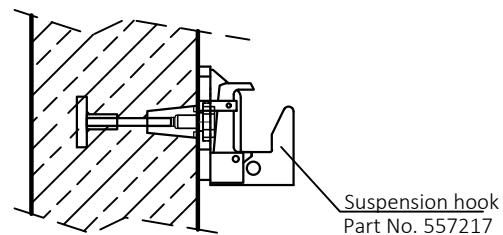

Range of application see system description.

Minimum concrete strength  
25 N/mm<sup>2</sup>

Required parts :	Part No.
Counter plate	557213 *
Rod with tie rod thread.... lg., black	76.... *
Tie cone with tie-rod-thread	686900
Nailing plate for tie cone	811991
Steel cone	557212
Bolt Tr26x5 50lg. SW 55	822400
Suspension hook	557217
Pipe-head shaped key SW 32 for tie cone	394901
Spanner for nailing plate	466712
Key for steel cone	811920
Tube spanner SW 50/55 for bolt	390355

\* Lost parts

### 5.6 Suspending the scaffold unit

#### 1. Suspension

Blocking clip (1) swung up and locking clip (2) open.

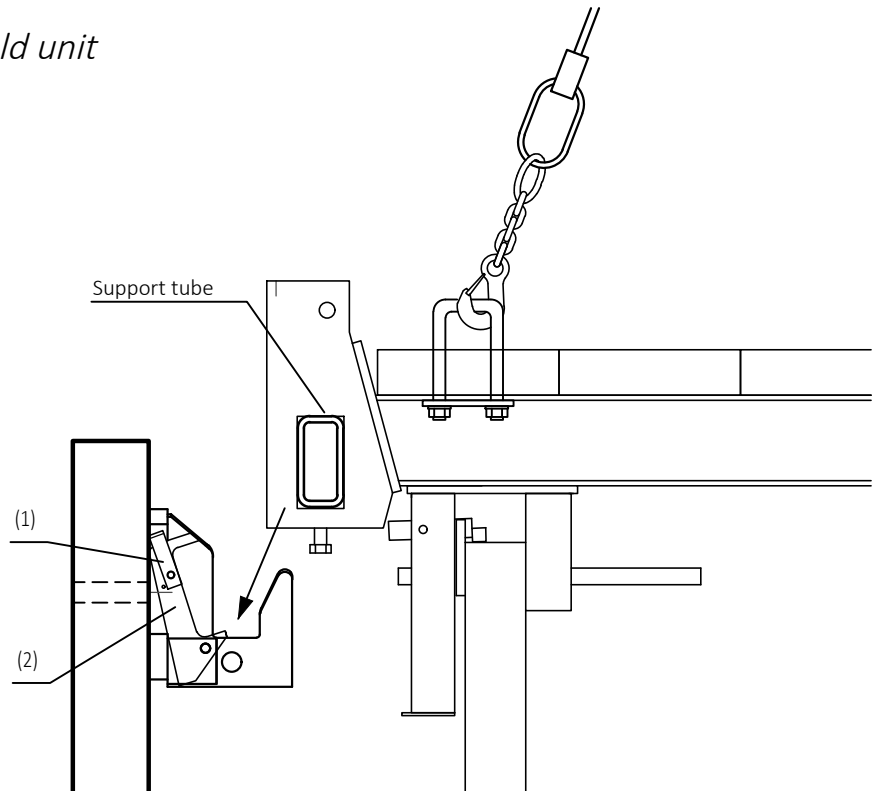

#### 2. Automatic securing

In preparation for suspension, the locking clip (2) swings into the closed position as the support tube is placed down on it and is automatically secured by the blocking clip (1).

 Check whether the blocking clip passes around the support tube as shown !!

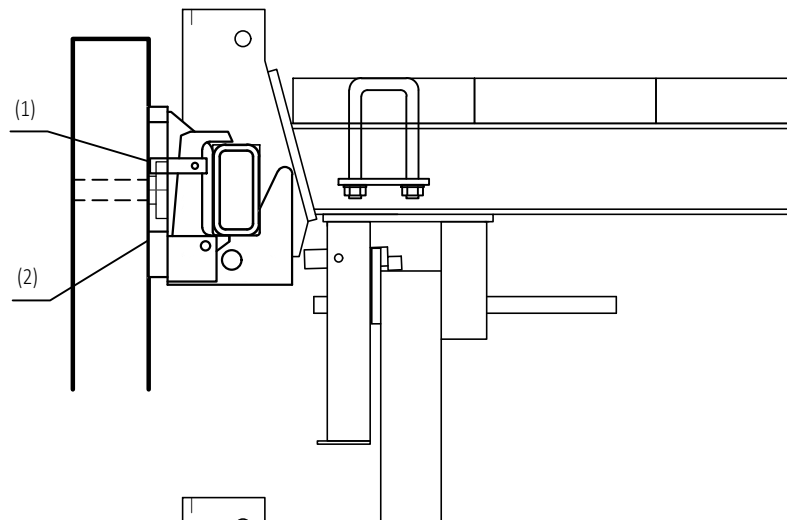

#### 3. Automatic unlocking

To lift the bracket, first lift the blocking clip (1). The locking clip (2) swings back automatically into the original open position (see above).

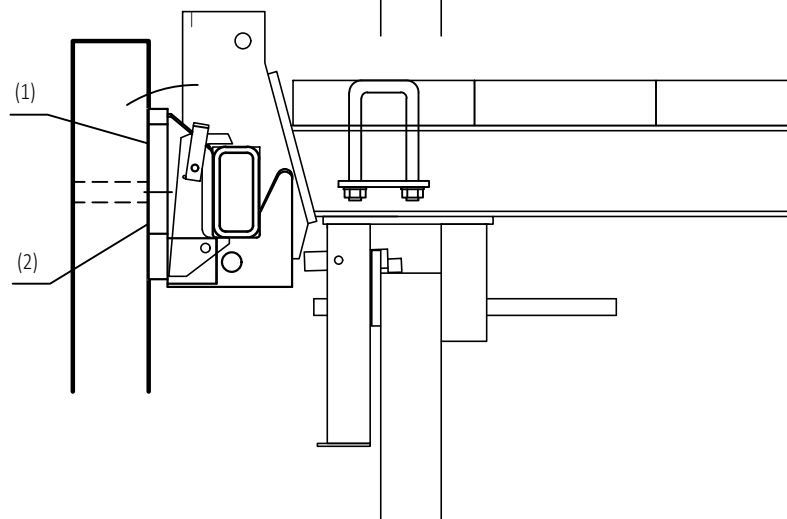

5.7 Tying down against wind uplift on the panels

As soon as the working platform is in place with the formwork panels, the system must be tied down.

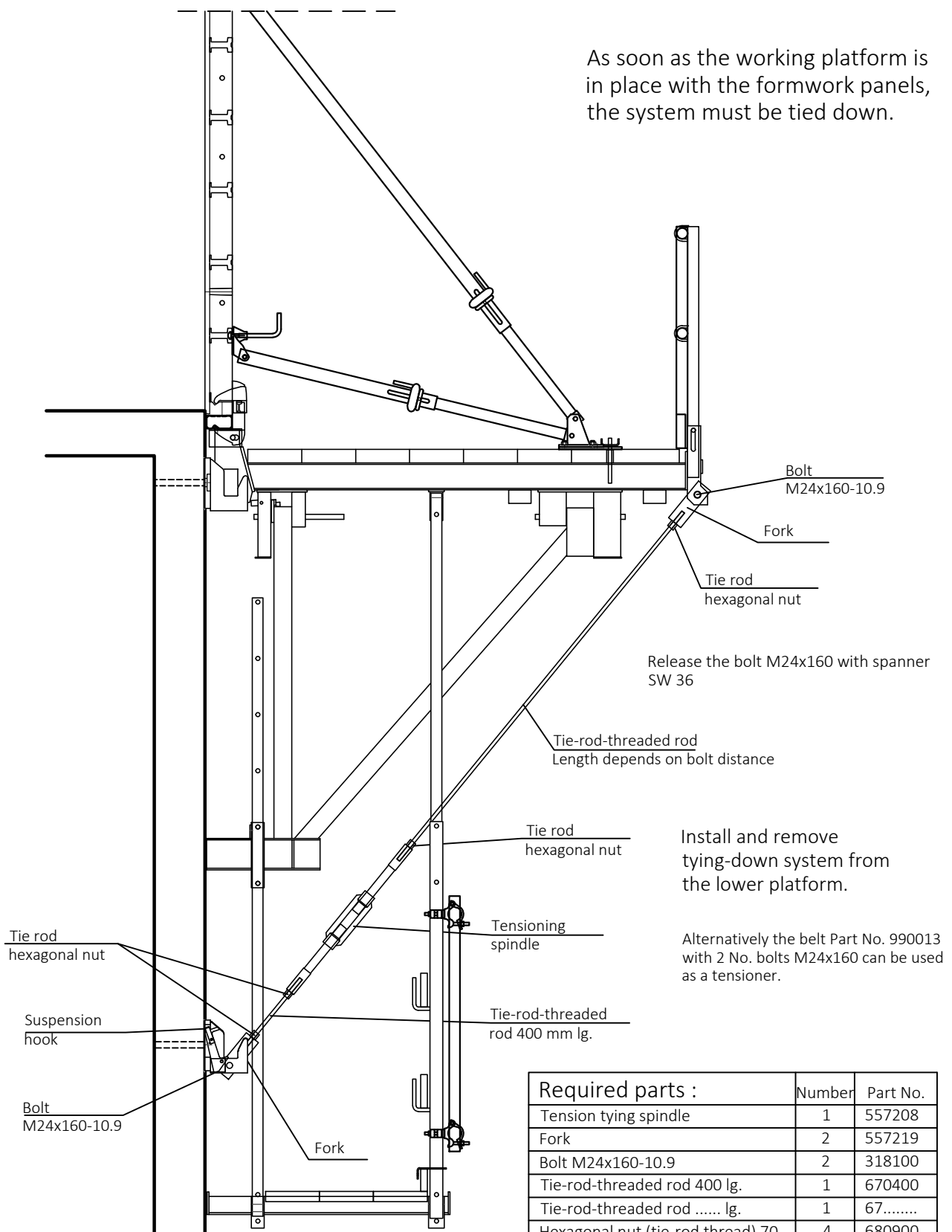

Required parts :	Number	Part No.
Tension tying spindle	1	557208
Fork	2	557219
Bolt M24x160-10.9	2	318100
Tie-rod-threaded rod 400 lg.	1	670400
Tie-rod-threaded rod ..... lg.	1	67.....
Hexagonal nut (tie-rod thread) 70	4	680900
Open spanner SW36	1	390900

## 6. Use with travelling channel and travelling device

### 6.1 Overview

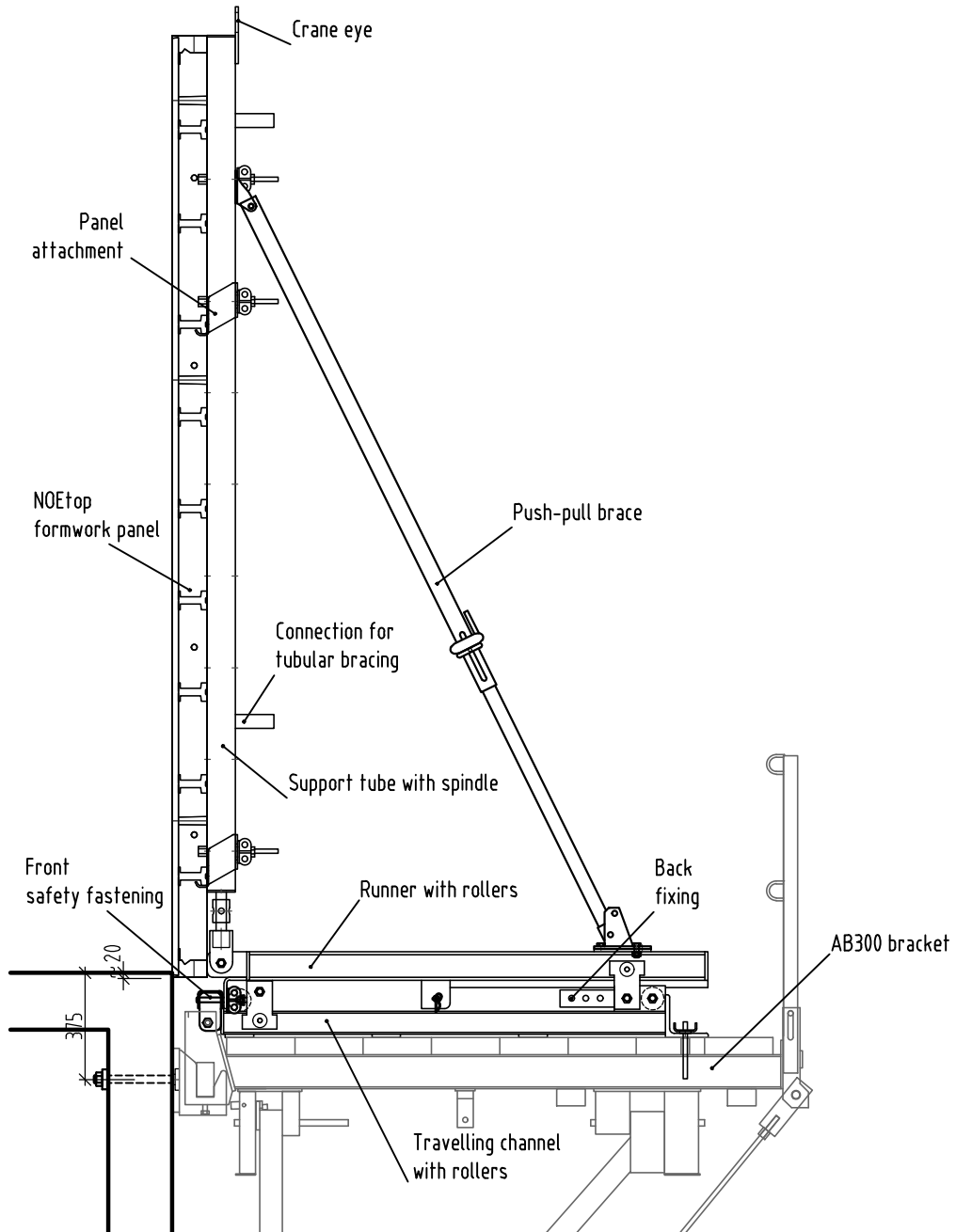

### 6.2 Use of the AB300

- ◆ Before concreting the wall or slab, plan out the formwork and falsework and determine the tie rod spacings. Refer to the design tables. Concrete in the tie rods in such a way that the suspension hook can be fastened in position later.  
 After the concrete has reached the required strength, fasten the suspension hook in position and attach the scaffold.

➔ Refer to Points 4 and 5 for this.

### 6.3 Mounting the runner on the bracket

- ◆ Bolt the travelling channel (1) and front safety fastening (2) with bolt M20x140 (3) to the bracket and fasten to the sunken nut in the bracket with the wing head bolt (4).
- ◆ Fasten the roller (5) with bolt M20x100 (6) and additional washers (7) to the travelling channel.

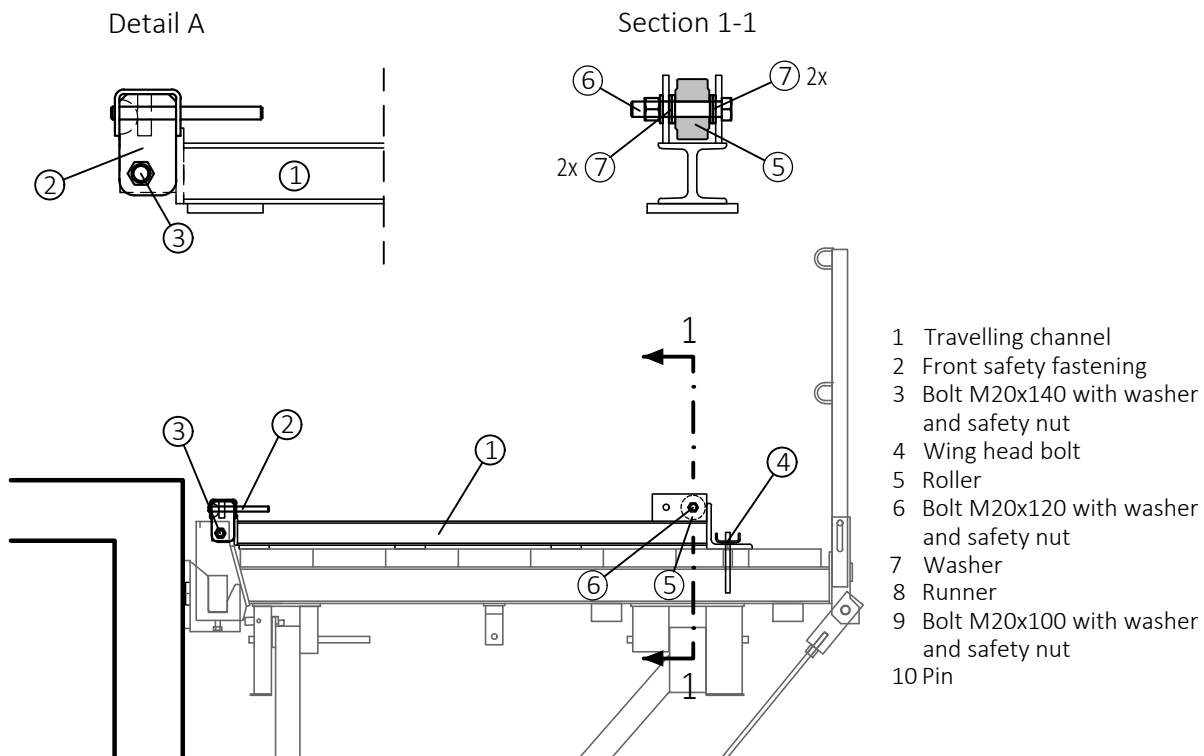

- ◆ Bolt the second roller (5) with bolt M20x100 (9) and additional washers (7) to the runner (8). Insert the safety pin (10) into the opening on the runner and secure.

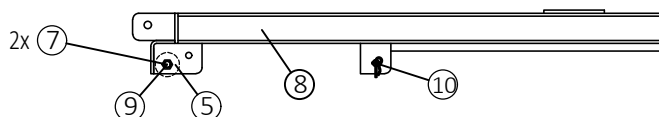

- ◆ Place pre-assembled runner (8) on to the travelling channel (1). Fasten the back fixing (11) and a wheel flange (12), with the rollers upwards, to the travelling channel with bolt M20x120 (6). Fasten the other wheel flange (12) with the rollers downwards, at the front on to the runner with bolts M20x120 (6). The runner is held at the sides with this arrangement and secured against uplift.

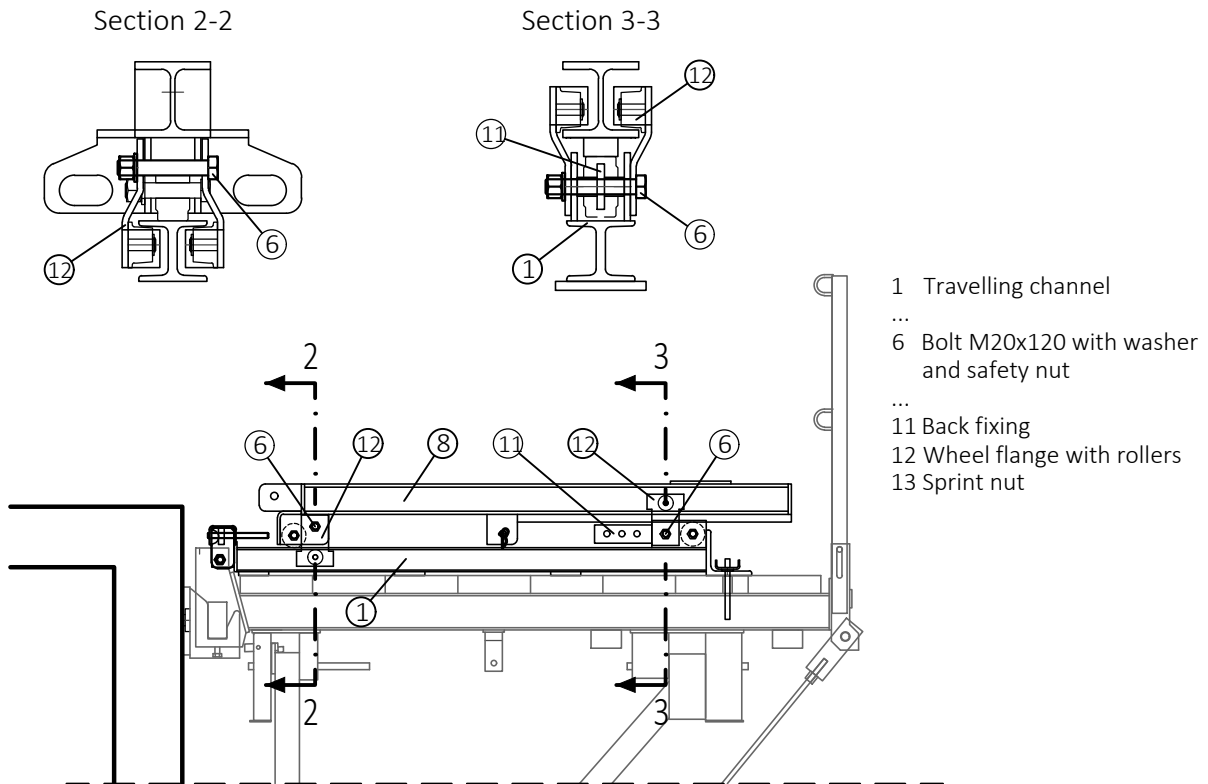

- ◆ Push the runner (8) as close to the front safety fastening (2) as possible, until the 2 Sprint nuts (13) can be tightened to secure the assembly in place.

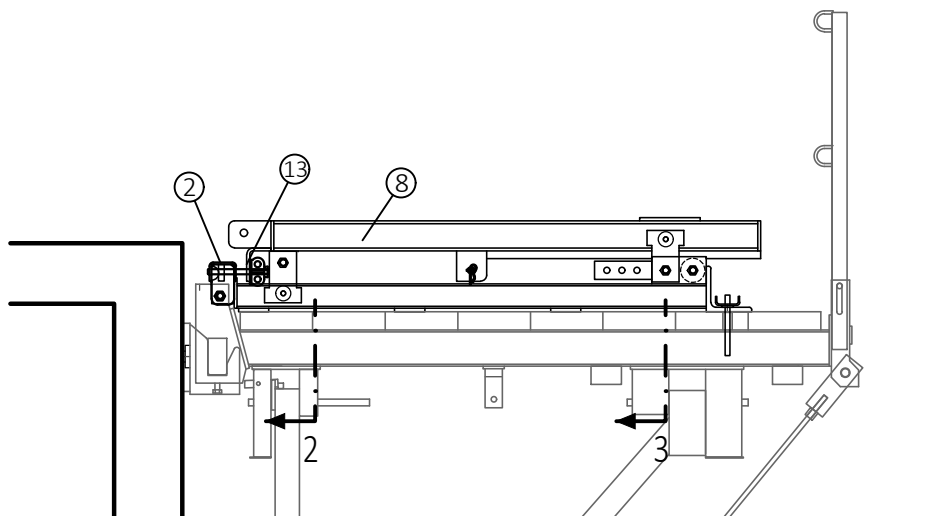

### 6.4 Install support tube and panel system

- ◆ Bolt support tube (1) with spindle (2) and bottom spindle mount (3) to the runner (5) with bolt M20x100 (4). Secure the spindle against screwing out with cotter pins.
- ◆ Bolt the bottom support of the push-pull brace (6) to the runner (5) with 2 bolts M16x40 (7). Set the support tube vertical, pull out the brace and fasten the head support to the support tube (1) with the connection bolt (8) and Sprint nut (9).
- ◆ Stiffen the support tubes with at least a pair of tubular bracing members connected to the connections for the tubular bracing  $\varnothing 48$  (10)..

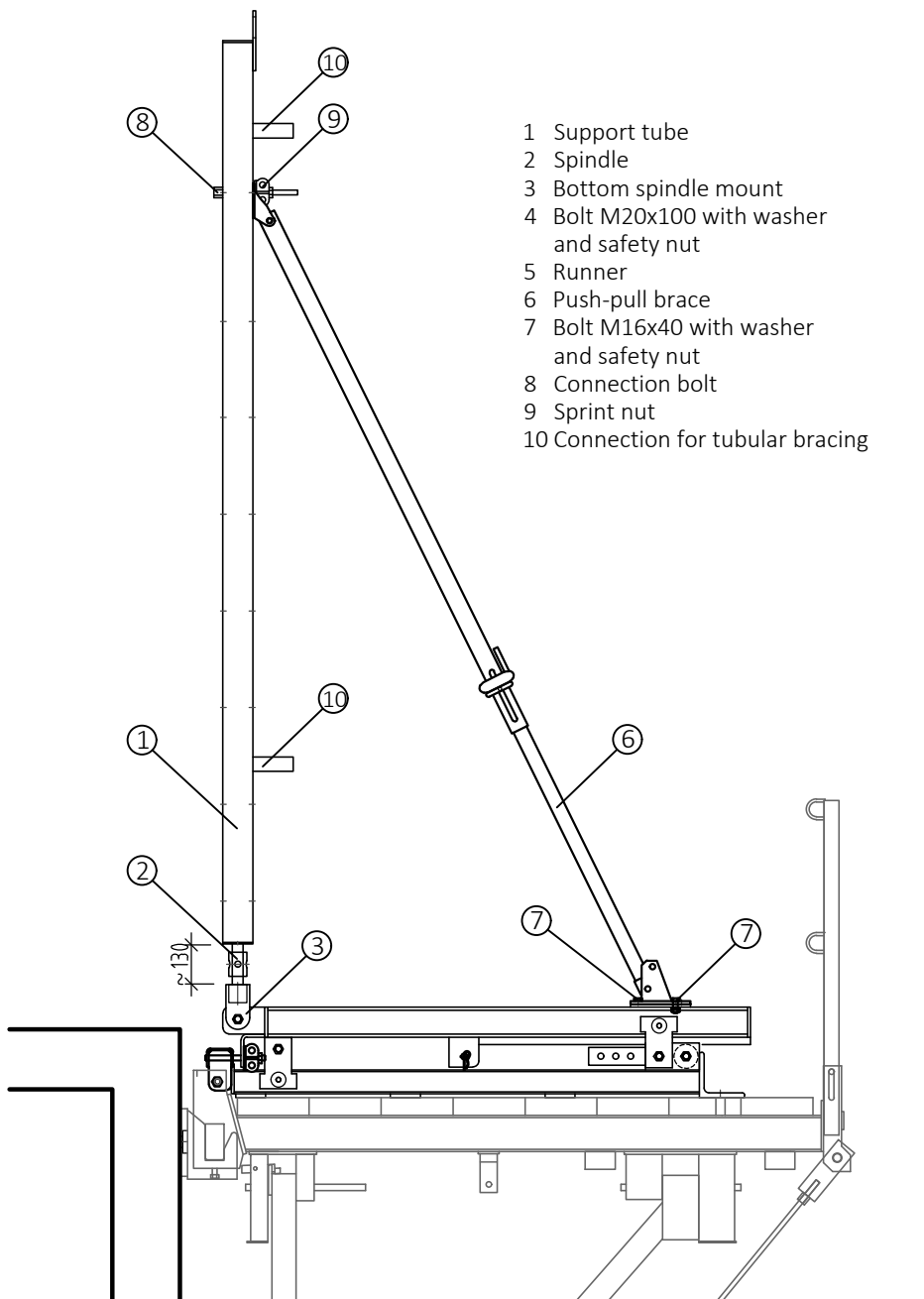

- ◆ Fasten 2 fastening bows (2) onto the support tube (1) each with 1 connection bolt (3) and Sprint nut (4).
- ◆ Suspend the NOEtop formwork panel (6) on the hat profile in the connection bow (2) and fasten each one on to the hat profile with 2 hammerhead bolts (5).

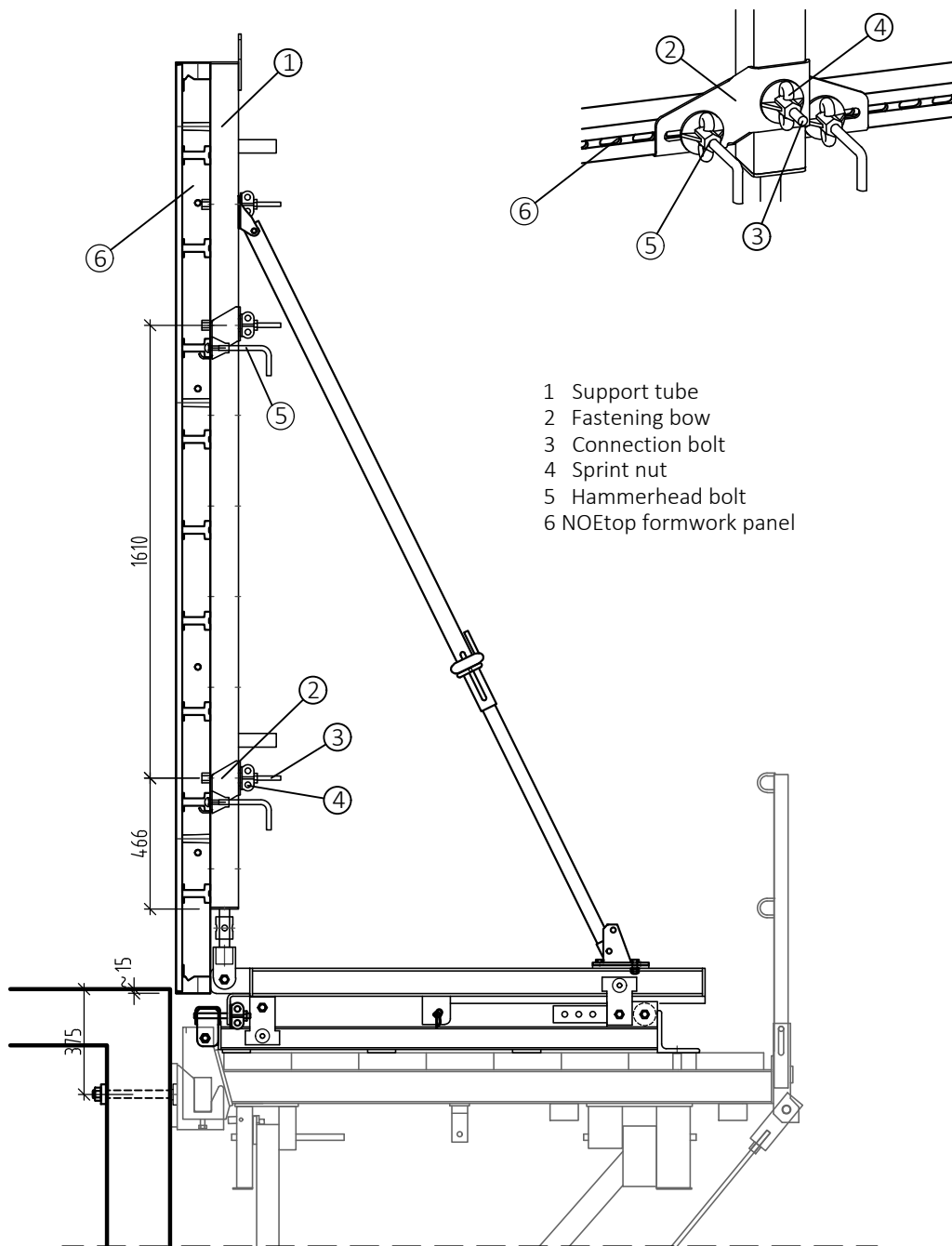

- ◆ Adjust the height of the formwork panels with the spindle on the support tube. Push the runner and attached the formwork panels up to the wall by tightening the Sprint nut at the front safety fastening. Align the formwork panel system with the push-pull braces.



### 6.5 Retract the formwork panel

- ◆ Remove the 2 Sprint nuts from the front safety fastening (1), release the formwork panel from the concrete and move the assembly back with the runner. Before being transported by crane, the formwork panel must be moved forward and fastened in position with Sprint nuts at the front safety fastening (1).

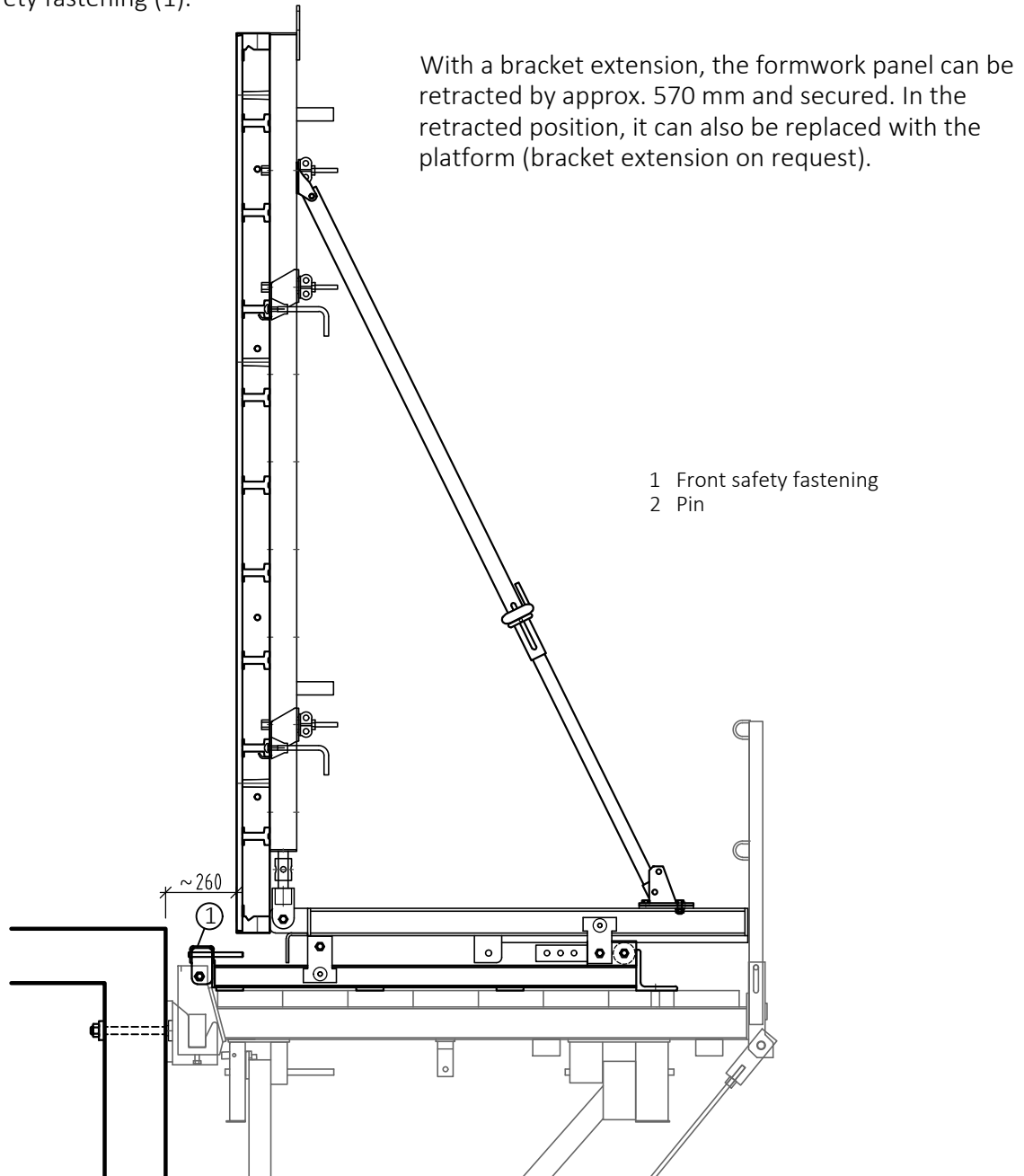

- ◆ Attach crane hooks to the crane eyes of the support tube, release the safety device on the suspension hook and move the complete unit with formwork into position for the next use.
- ◆ Attach and secure the brackets in the mounted suspension hooks. Only then release the unit from the crane. After cleaning, oiling etc. move the formwork panel forward again and secure the runner as described above.

6.6 Climbing process without travelling device

 Climbing without the travelling device in place must not be carried out with the formwork panel attached !

Section

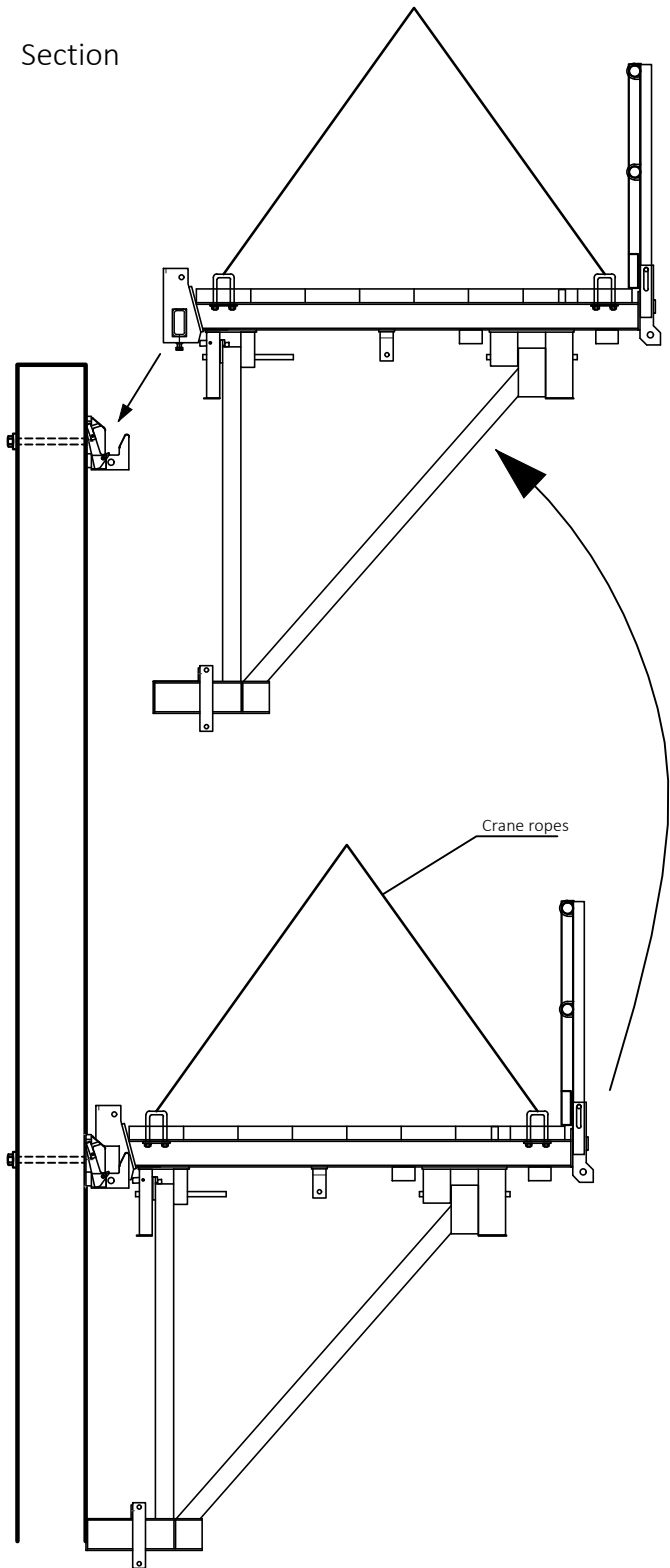

- Remove wall formwork from the climbing scaffold
- If the assembly is tied down, release the ties at the lower suspension hook
- Attach the quadruple crane ropes to the stirrups sunken into the boarding
- Lift the blocking clip on the bracket and move the unit to the next position.

7. Use without travelling device

7.1 NOEtop formwork with AB300 support channel

Section

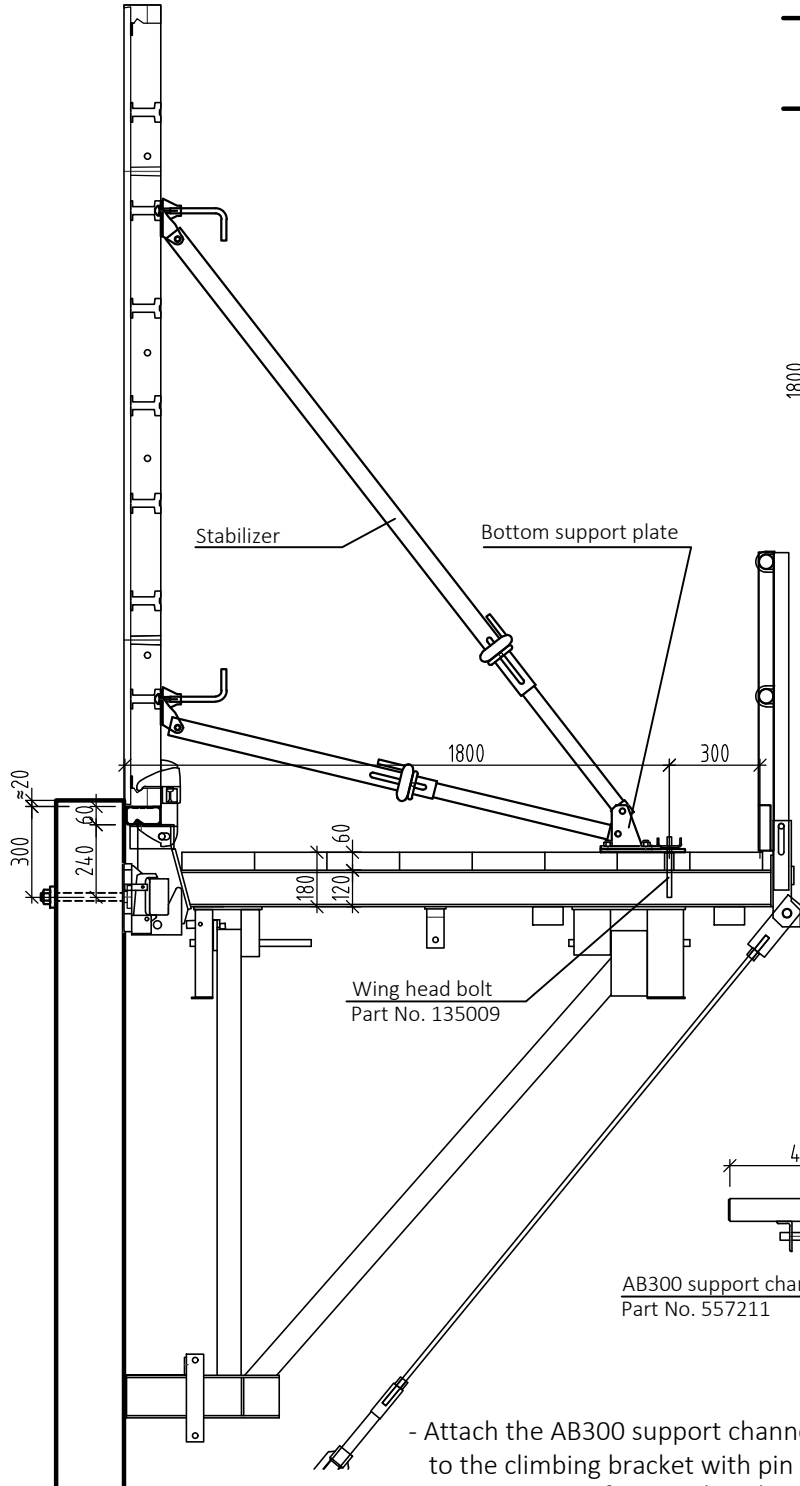

Plan view  
 Max. swivelling range of the stabilizer

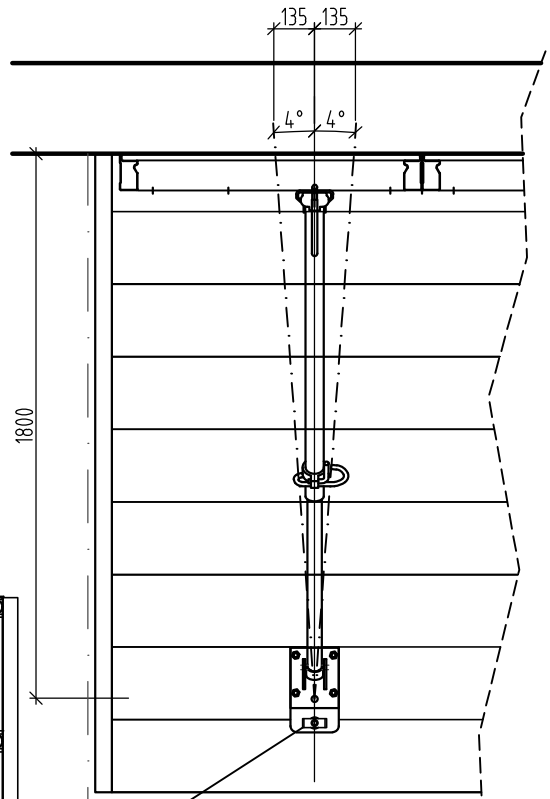

Bolt stabilizer with wing head bolt Part No. 135009 to screw socket in climbing bracket.

Detail - Base

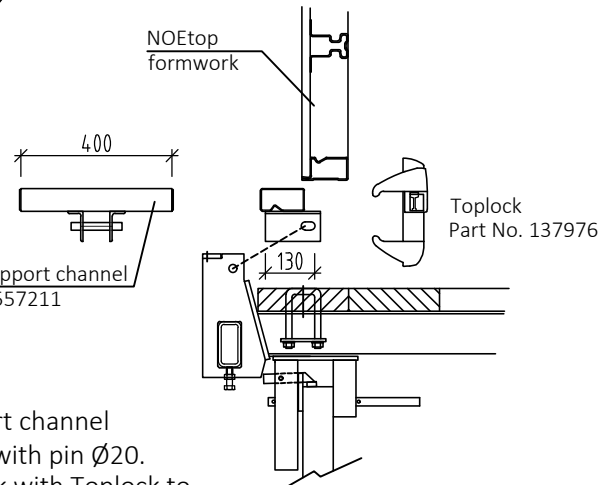

- Attach the AB300 support channel to the climbing bracket with pin  $\varnothing 20$ .
- Fasten NOEtop formwork with Toplock to AB300 support channel.

7.2 Formwork panel without travelling device

Section

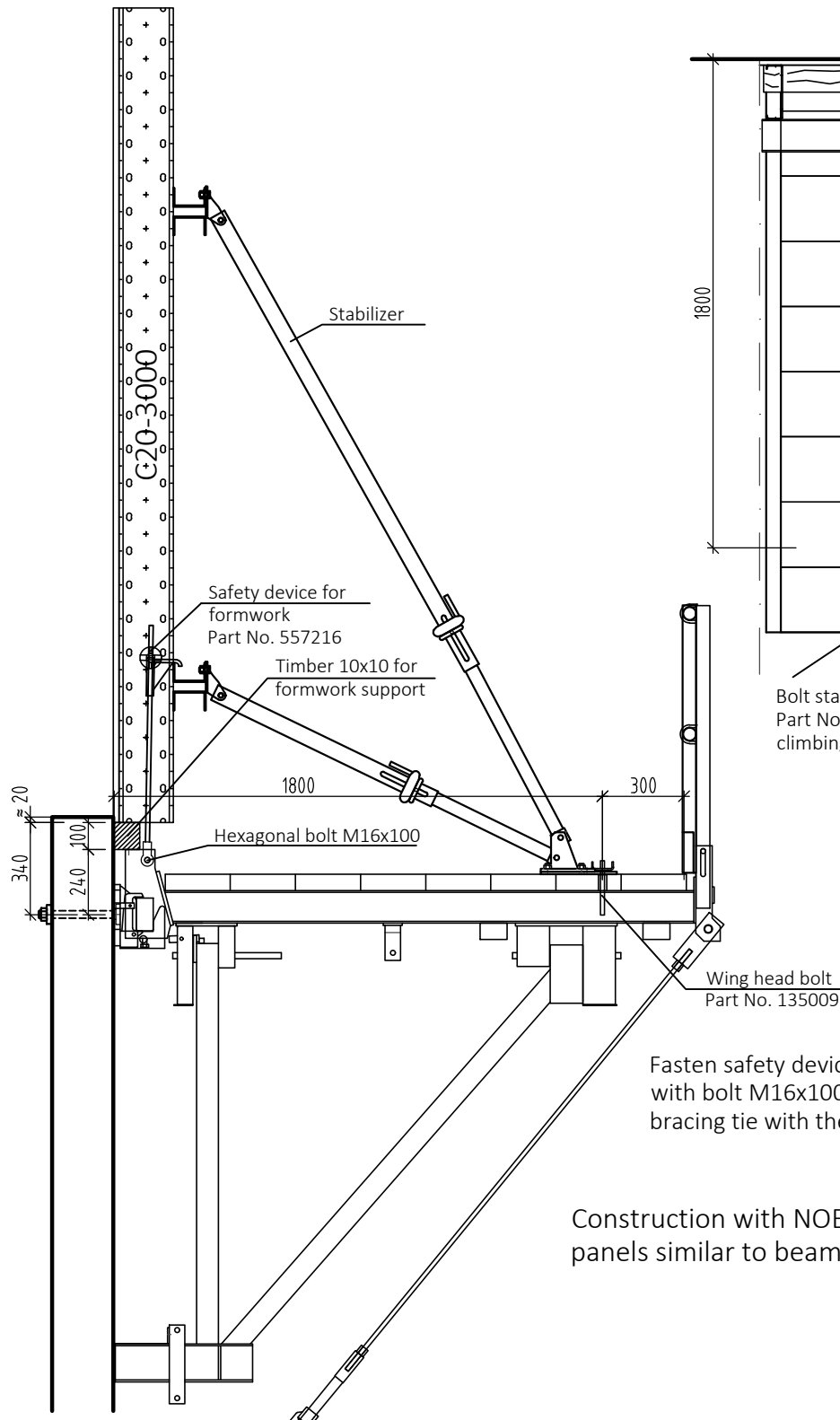

Plan view

Max. swivelling range of the stabilizer

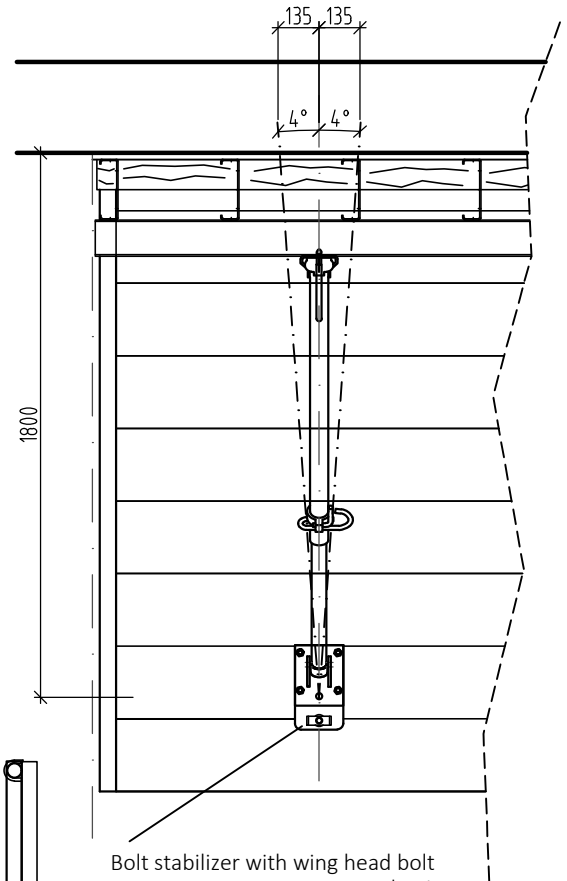

Bolt stabilizer with wing head bolt Part No. 135009 to screw socket in climbing bracket.

Fasten safety device for formwork to the bracket with bolt M16x100 and tighten claw against the bracing tie with the Sprint nut.

Construction with NOETop formwork panels similar to beam formwork system

## 8. Practical solutions for various situations

### 8.1 Bridging wall openings

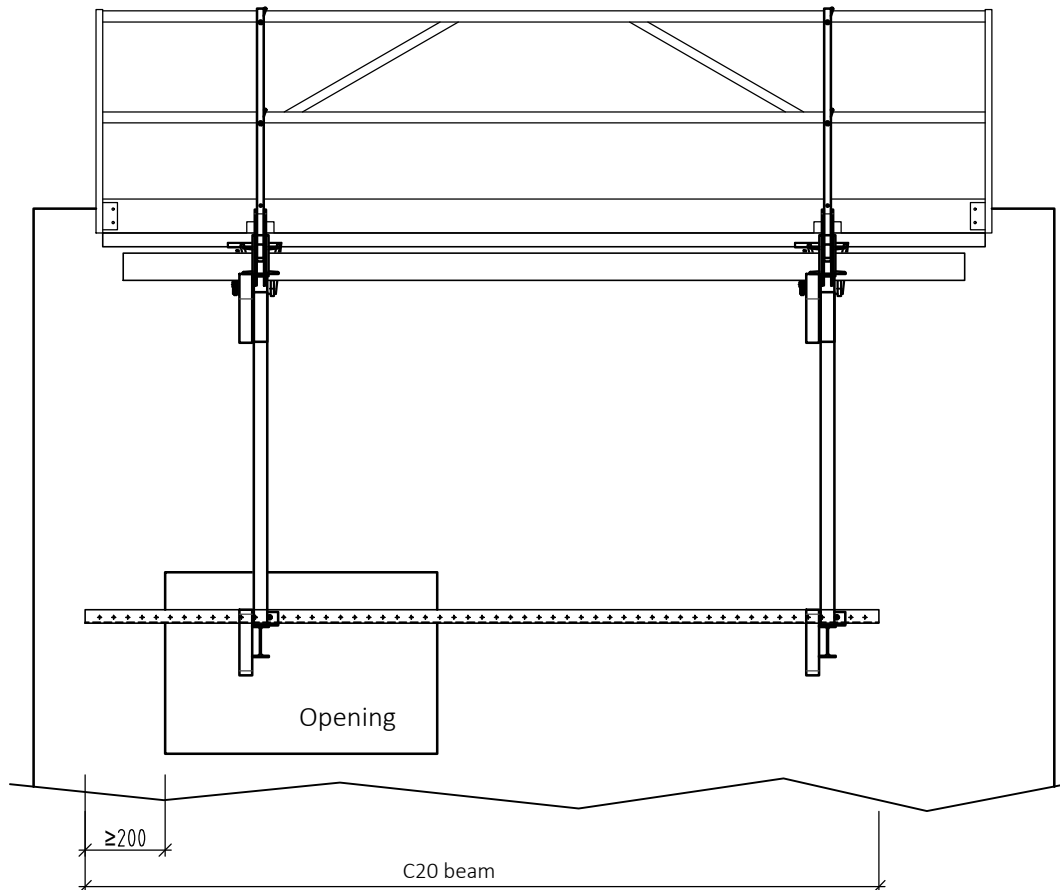

The C20 beam must press against the wall on both sides of the wall opening in order to bridge the wall opening.  
For wall openings  $\geq 900$  mm a structural engineering check must be carried out, or U200 profiles used.

In the case of a suspended platform, a bridging beam must be similarly attached at the wall opening.

C20 beam

200

Bolts M16x40 1x per bracket

Section

### 8.2 Guard rail extension with protective net

Section

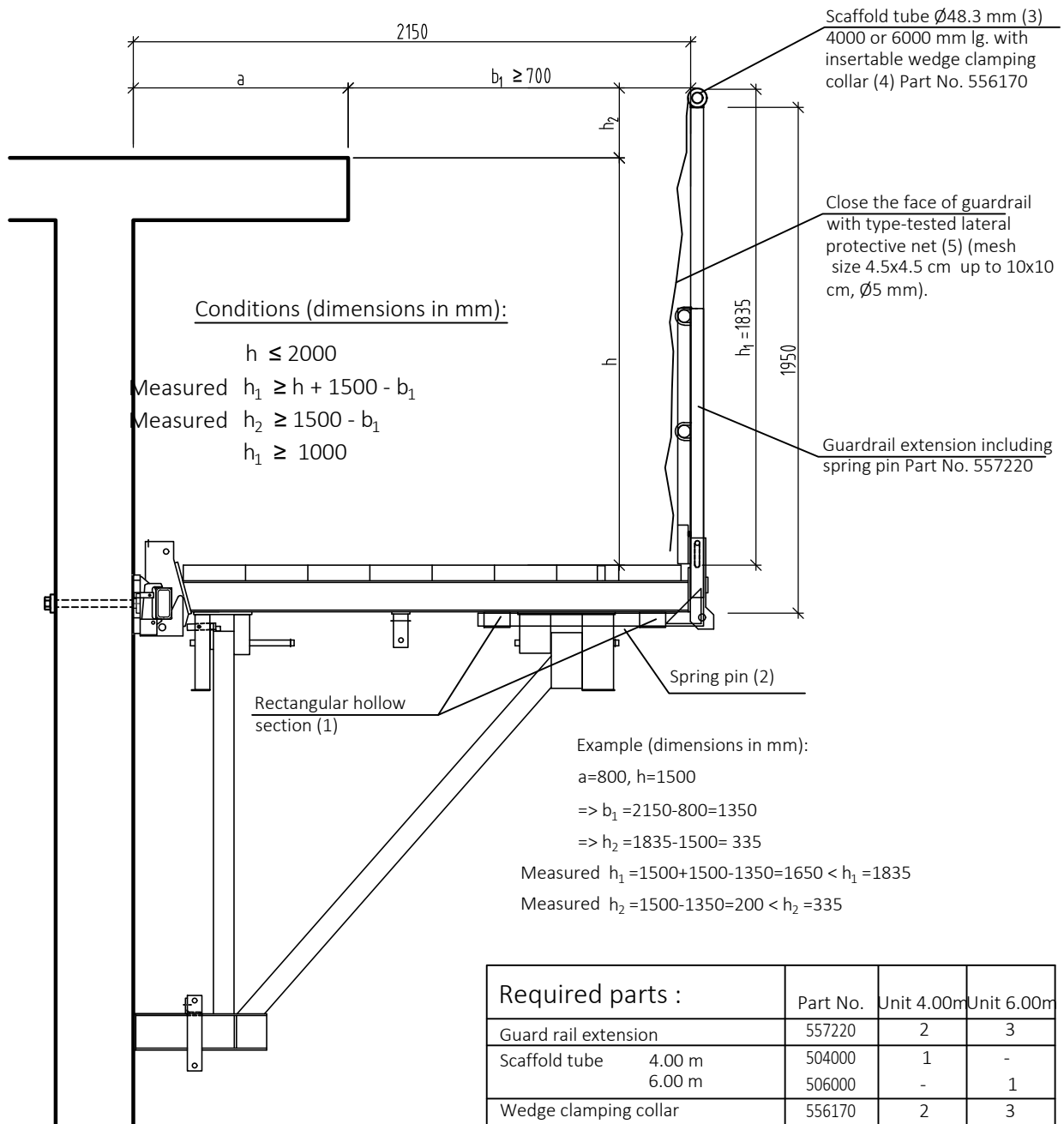

Protective net 10.0 x 2.0 m Part No. 556190  
5.0 x 2.0 m Part No. 556180

- Insert guard rail extension through lateral rectangular hollow section (1) on to bracket and secure with spring pin (2)
- Insert scaffold tube (3) and wedge clamping collar (4) in guard rail extension
- Attach type-tested lateral protective net (5)

8.3 Internal corner

View A

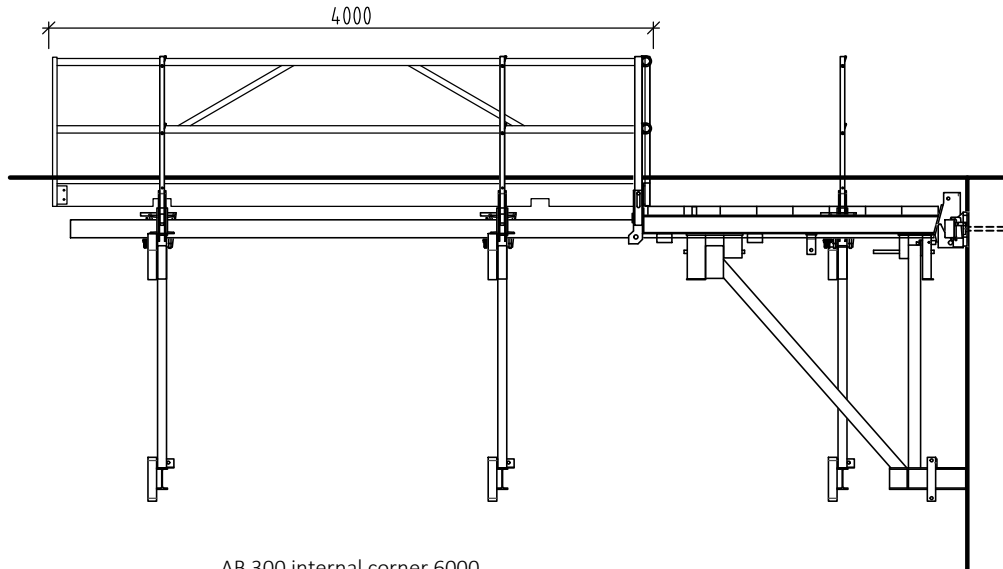

Plan view

AB 300 internal corner 6000 mm Part No. 557266

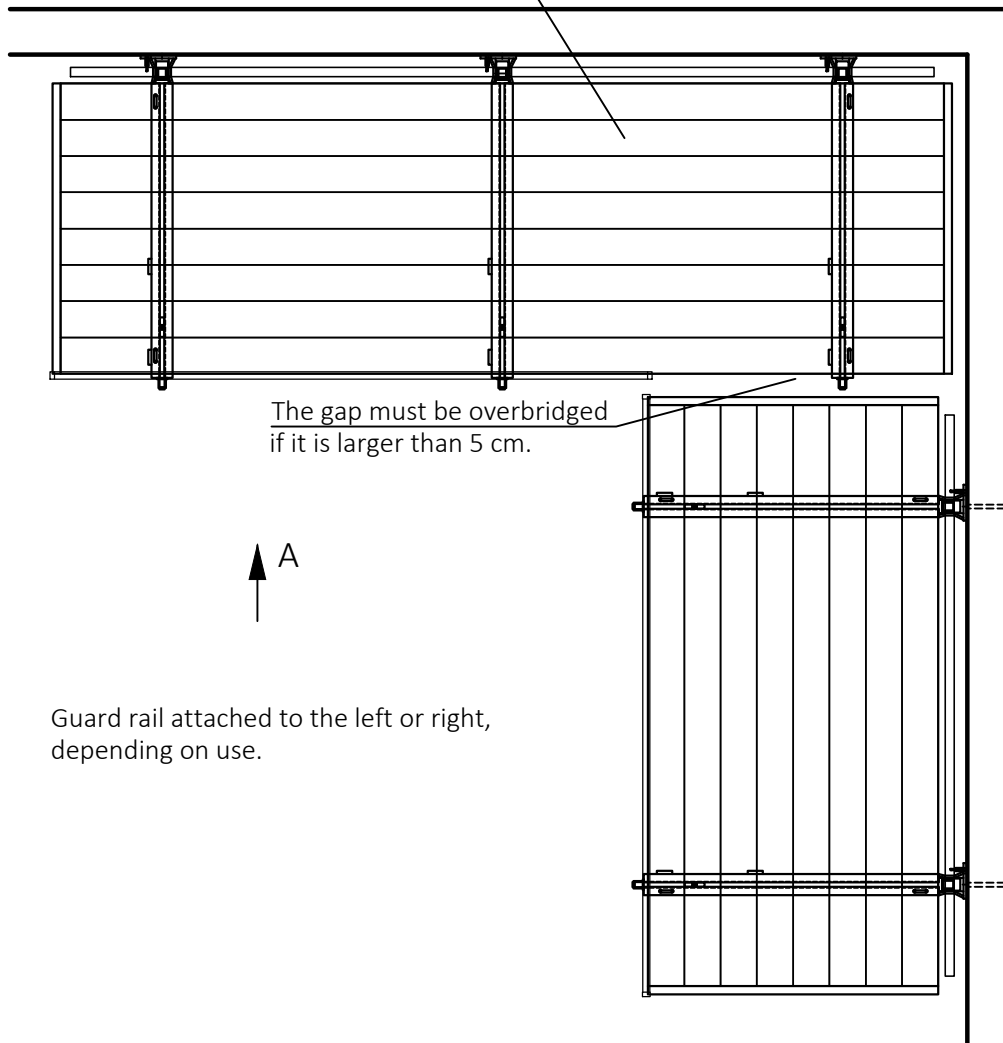

Guard rail attached to the left or right, depending on use.

8.4 External corner

Plan view

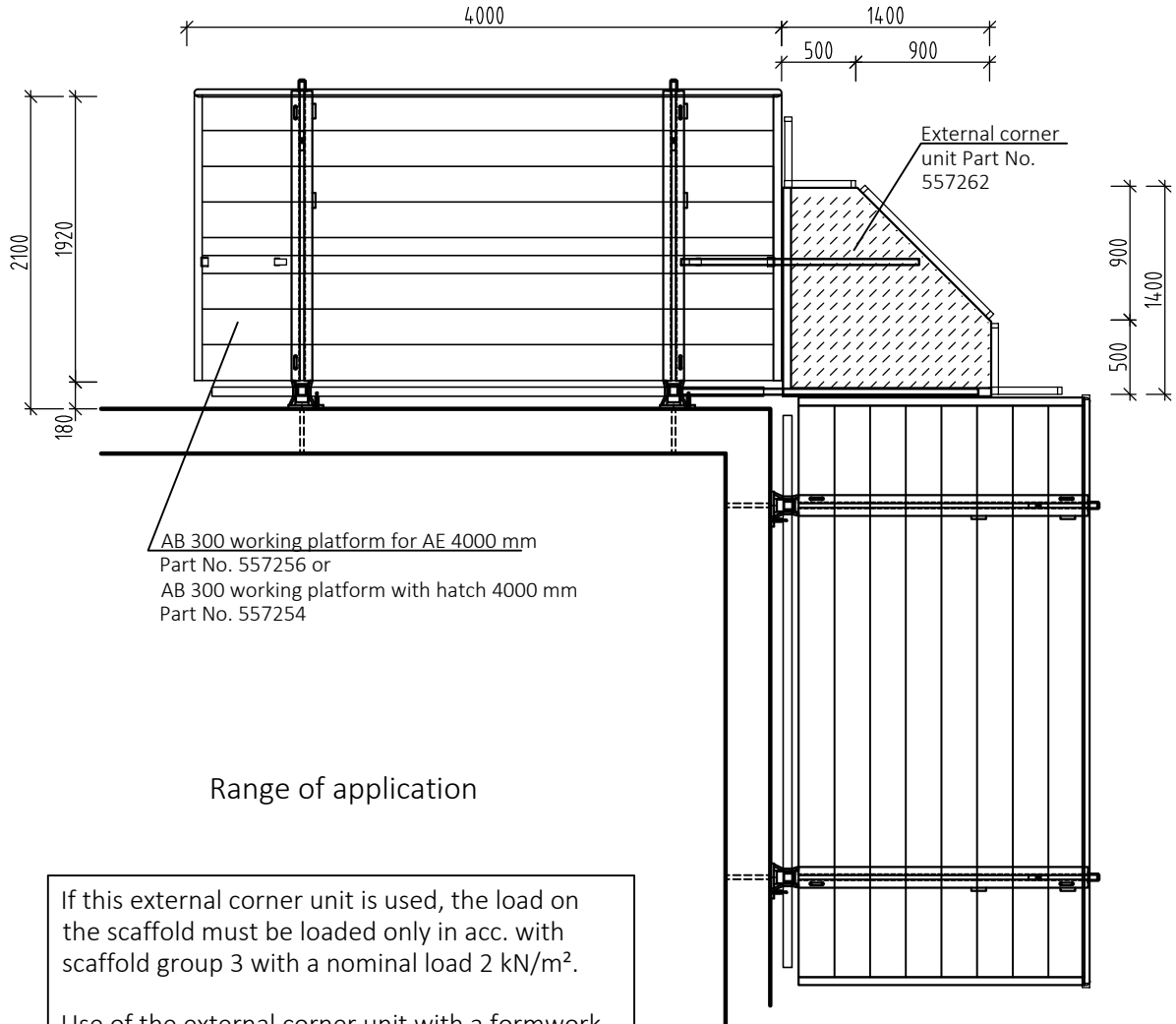

Range of application

If this external corner unit is used, the load on the scaffold must be loaded only in acc. with scaffold group 3 with a nominal load 2 kN/m<sup>2</sup>.

Use of the external corner unit with a formwork panel system is not permissible unless the suspension hook is fastened with anchor bolts M36x430 or scaffold bolt M36 (see Suspension), Panel height ≤ 4.00 m.



### 8.5 Assembly of the external corner

Plan view

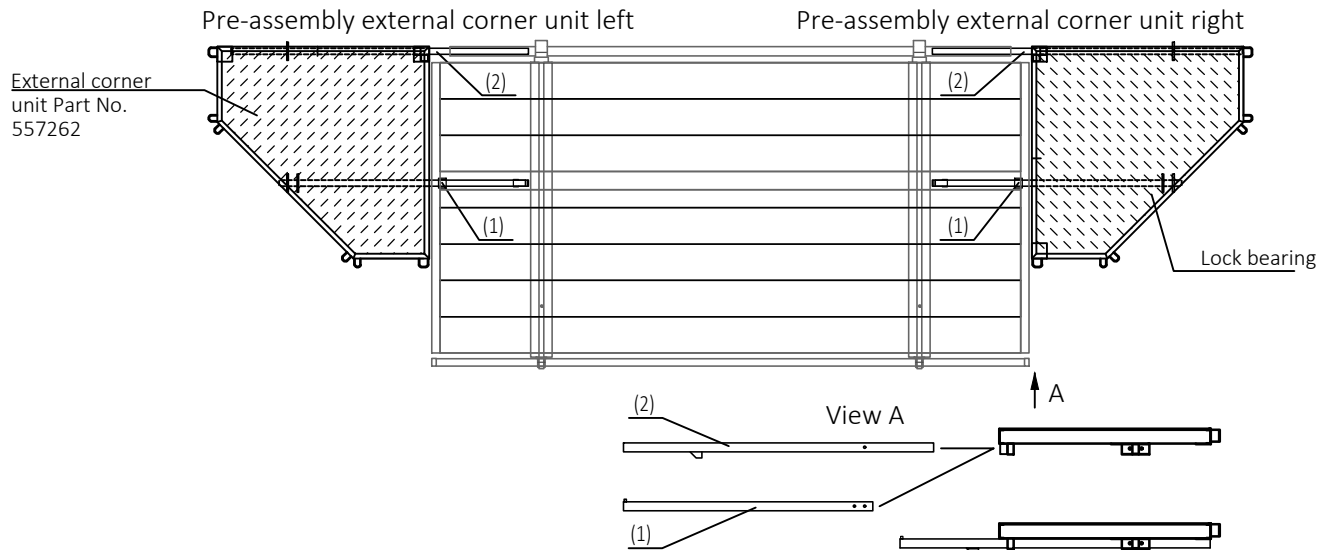

- Insert short slot-in tube (1) into the lock bearing of the corner unit with cams pointing upwards and secure with 2 spring pins in front and behind the rear lock bearing.
- Insert long slot-in tube (2) into the lock bearing of the corner unit with cams pointing downwards and secure at the rear lock bearing with 1 spring pin.

- Insert short slot-in tube (1) into the lock bearing of the corner unit with cams pointing upwards and secure at the rear lock bearing with 2 spring pins.
- Insert long slot-in tube (2) into the lock bearing of the corner unit with cams pointing downwards and secure at the rear lock bearing with 1 spring pin.

### Elevation

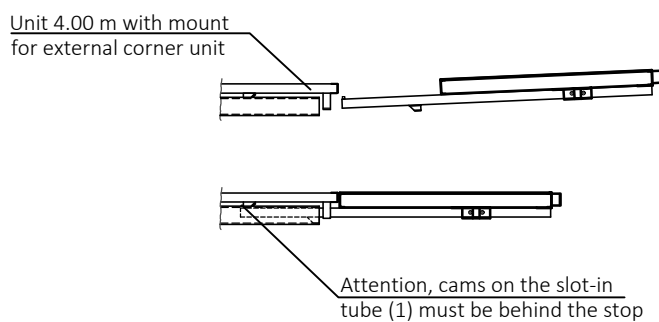

### Assembly external corner unit

- Lift external corner unit and push into unit 4.00 m with mounting for external corner unit or unit with hatch as far as it will go so that it is automatically locked in the horizontal position.
- Insert guard rail (3) and 2 corner guard rails (4) on the external corner unit into the mount for guard rail. Guard rails not included in external corner units.

	No.	Part No.
External corner	1	557262
Guard rail I	1	557222
Guard rail II	2	557223

Guard rail I



Guard rail II

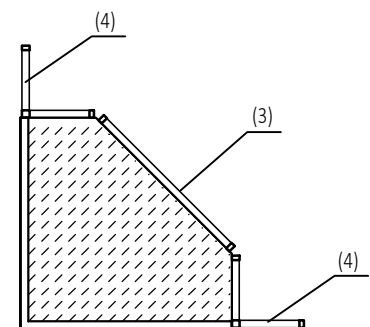
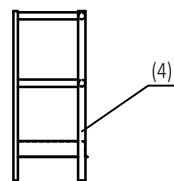

8.6 End guard rail

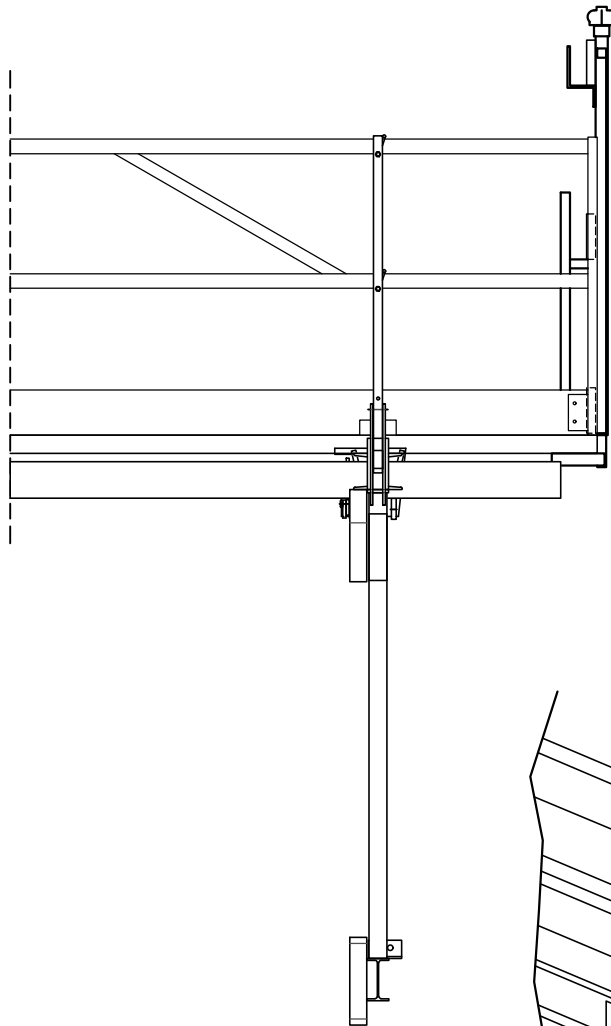

Handrail clamp  
Part No. 900052  
Weight 14.2 kg

End guard rail on suspended  
lower platform constructed  
similarly.

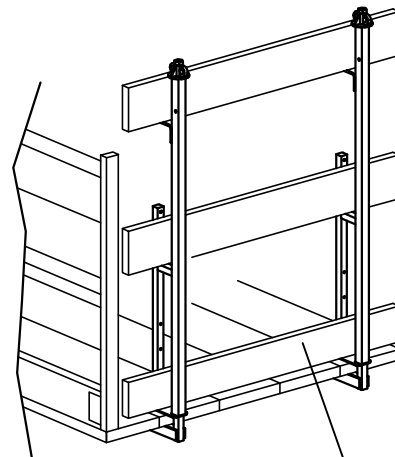

Guard rail board min. 3x15 cm

- Clamp guard rail clamp to boarding
- 2 Attach guard rail boards and toeboard

8.7 Connecting platform  
 Part No. 557264

Section

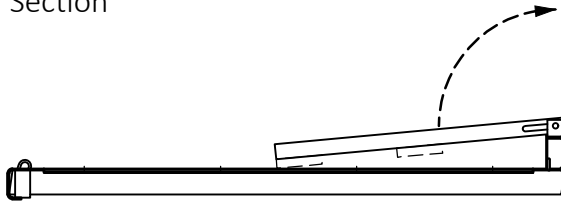

The guard rail of the connecting platform can be folded down for transport. Before use, fold out the guard rail and press the guard rail posts downwards (see also Assembly process scaffold).

Use a quadruple sling rope when moving by crane. Attach the crane ropes to the crane suspension points at the sides (4 No).

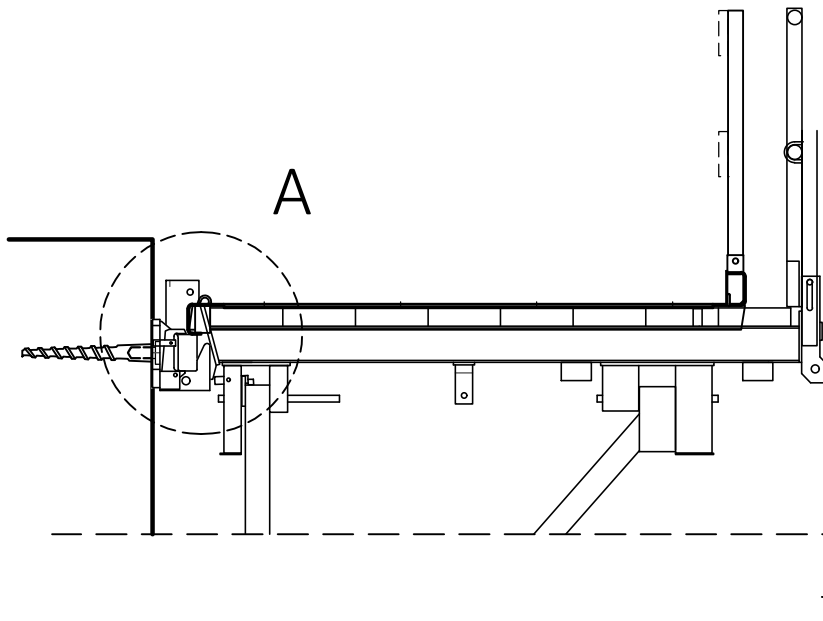

Place the connecting platform centrally between the scaffold units and tighten with the lateral stop against the scaffold boards. Fix the connecting platform at both sides to the scaffold boards with nails.

Detail A

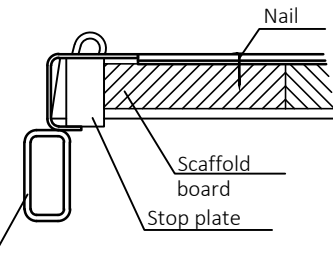

Plan view

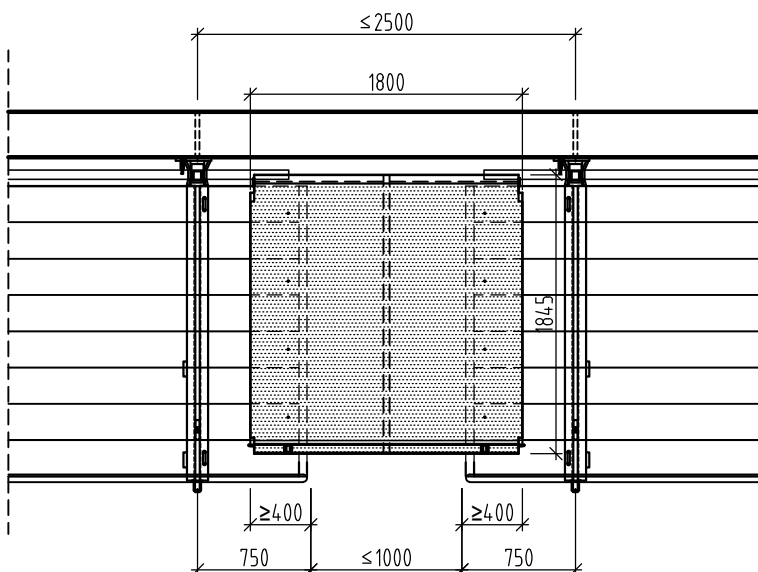

Range of application

Use of the connecting platform with a formwork panel system is not permissible unless the suspension hook is fastened with anchor bolts M36x430 or scaffold bolt M36 (see Suspension).

Height above ground	Panel height
≤ 24 m	4.00 m
≤ 100 m	3.00 m

8.8 Connecting lower platform

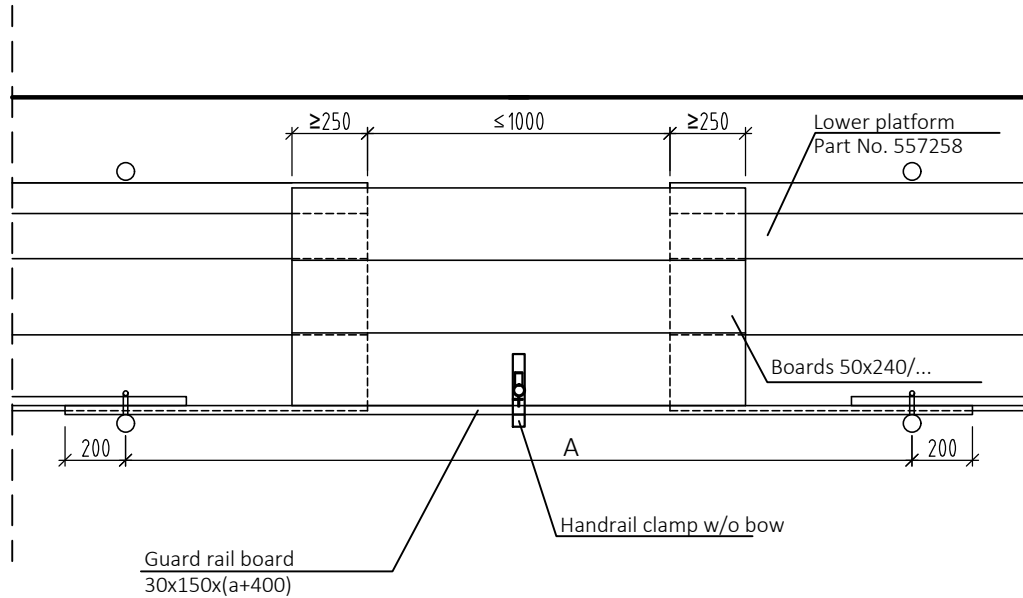

If A is greater than 2.0 m, a handrail clamp must be attached to the connecting platform boards !

8.9 Scaffold extension

For platform with hatch (200-500 mm, one or both sides)

Scaffold extension left  
 Part No. 557270

Scaffold extension right  
 Part No. 557268

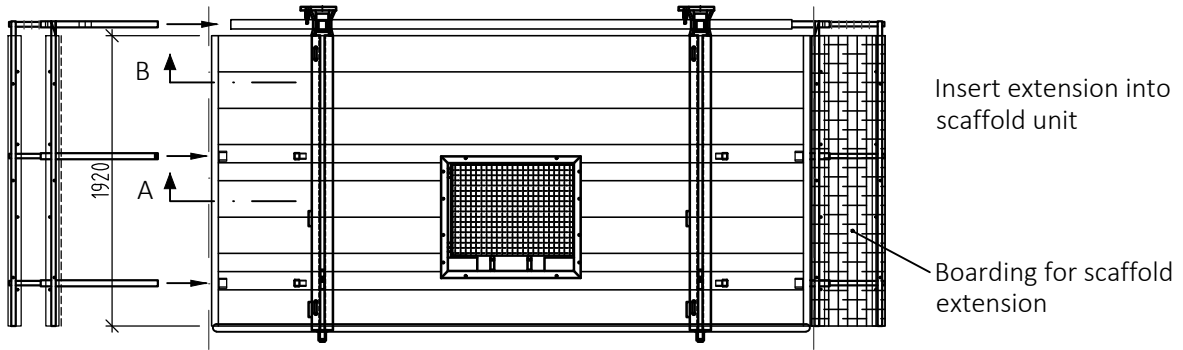

The scaffold extension is inserted on the left or right side into the straps and the support tube of the working platform with hatch. The AB 300 can be extended in this way on any side between 200 and 500 mm in increments of 50 mm.

Section A-A (Extension inserted)

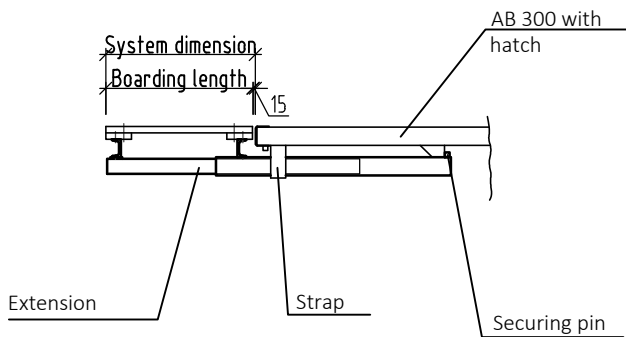

Boarding for scaffold extension

System dimension [mm]	Boarding length [mm]	Boarding weight [kg]	Weight total [kg]
200	185	4,6	48,1
250	235	5,8	49,3
300	285	7,1	50,6
350	335	8,3	51,8
400	385	9,6	53,1
450	435	10,9	54,4
500	485	12,1	55,6

Additional for scaffold extension:  
 Plywood for scaffold extension Part No. 557272  
 with information about the system dimension for the crossing length

Section B-B (Extension inserted)

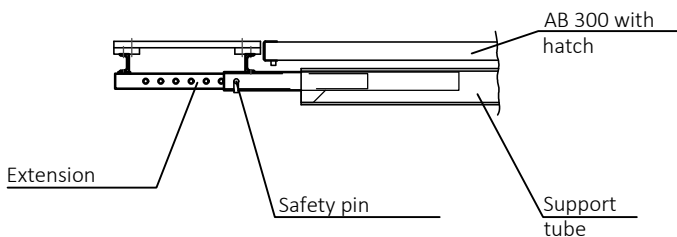

9. Individual parts of the travelling device

Support tube

Part No. 557234  
Weight 39.2 kg

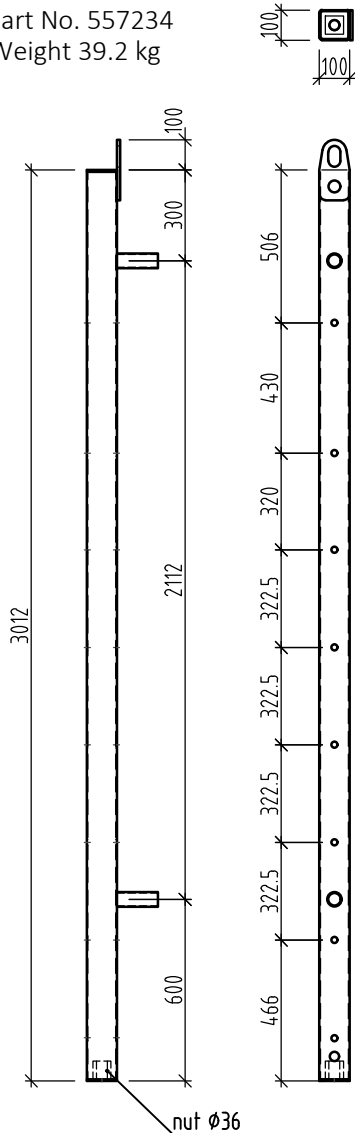

Runner

Part No. 557243  
Weight 52.5 kg

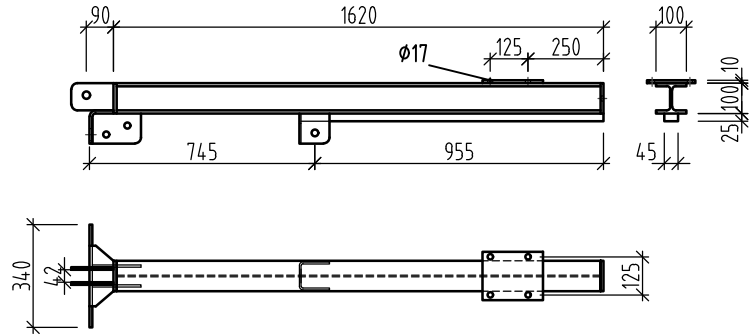

Wheel flange plate

Part No. 557241  
Weight 1.3 kg

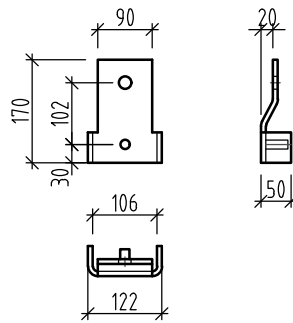

Wheel flange roller

Part No. 557244  
Weight 0.1 kg

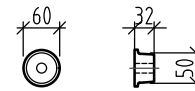

Plain washer A15

Part No. 381024  
pack 250 No.

Shaft safety ring A15

Part No. 389004  
pack 1000 No.

Bottom spindle mount

Part No. 557237  
Weight 3.3 kg

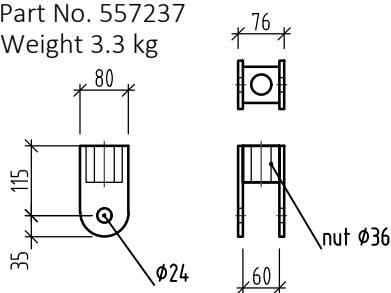

Spindle

Part No. 557238  
Weight 2.7 kg

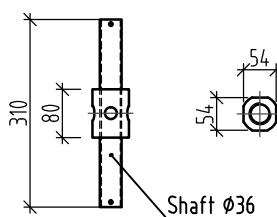

Guide roller

Part No. 557245  
Weight 0.2 kg

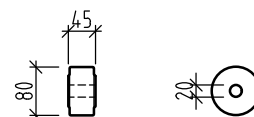

*Front safety fastening*

Part No. 557239  
 Weight 4.1 kg

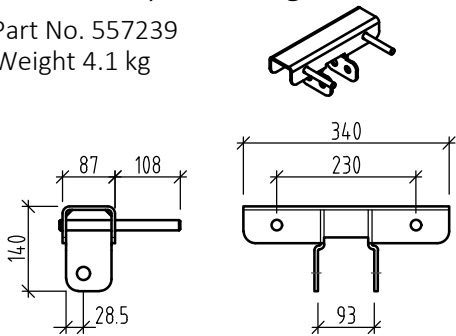

*Back fixing*

Part No. 557233  
 Weight 1.2 kg

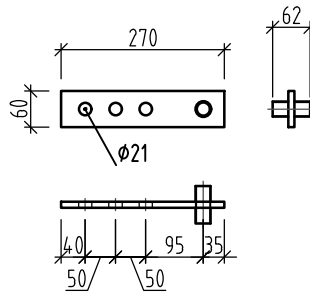

*Pin*

Part No. 557232  
 Weight 0.3 kg

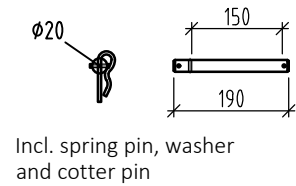

*Fastening bow for NOEtop*

Part No. 557242  
 Weight 3.5 kg

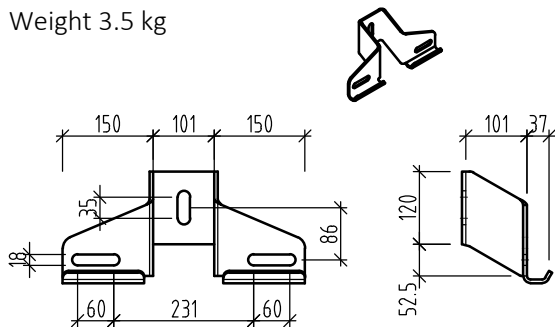

*Hammerhead bolt handle, head length 125 mm*

Part No. 319338  
 Weight 1.2 kg

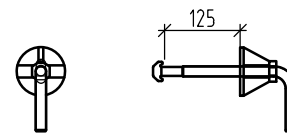

*Sprint nut 80*

Part No. 680580  
 Weight 0.7 kg

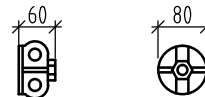

*NOEtop connection bolt*

Part No. 135019  
 Weight 0.6 kg

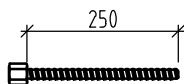

*bottom support plate*

Part No. 557276  
 Weight 3,6 kg

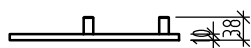
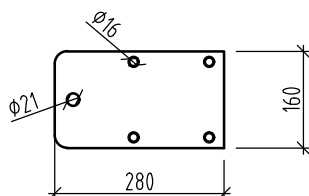

Fastening the bottom support plate with 4x M16 nut part no. 370025

*Supporting plate f. raking probs*

Part No. 697014  
 Weight 3,8 kg

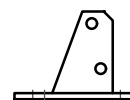
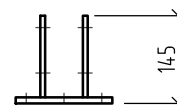
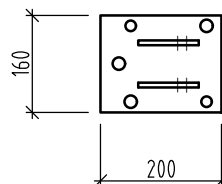

# Assembly and Operating Manual

## NOE AB300 Climbing scaffold



### *Bolts, nut and washers*

Part No.	Description	Weight [kg/piece]	Pack No.
362340	Hex-head bolt M16x 30 DIN 933 8.8	0,077	50
362344	Hex-head bolt M16X 40 DIN 933 8.8	0,09	50
360258	Hex-head bolt M16X 80 DIN 931 8.8	0,155	25
360264	Hex-head bolt M16x100 DIN 931 8.8	0,186	25
370024	Nut M16 DIN 934 8.0	0,03	200
380026	Washer A17 DIN 125	0,01	250
318000	Hex-head bolt M16x100, DIN 934 10.9	0,227	1
360366	Hex-head bolt M20X100, DIN 931 8.8	0,303	25
360370	Hex-head bolt M20X120, DIN 931 8.8	0,351	25
360374	Hex-head bolt M20X140, DIN 931 8.8	0,398	25
373016	Safety nut M20 DIN 985 8.8	0,065	100
380030	Washer A21 DIN 125	0,017	250
369004	Hex-head bolt M24x160, DIN 931 10.9	0,665	10
379000	Nut M24 DIN 934 10.9	0,22	50
380034	Washer A25 DIN 125	0,032	100



## 10. Overview of parts for 1 climbing bracket

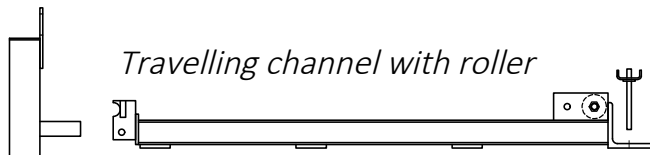

*Travelling channel with roller*

Part No.	Description	Number
557210	Travelling channel	1
135009	Wing head bolt	1
557245	Guide roller	1
360370	Bolt M20X120	1
380030	Washer A21	3
373016	Safety nut M20	1

*Runner with roller*

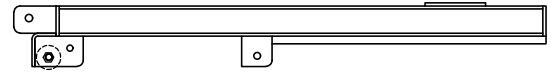

Part No.	Description	Number
557243	Runner	1
557232	Safety pin	1
557245	Guide roller	1
360366	Bolt M20x100	1
380030	Washer A21	3
373016	Safety nut M20	1

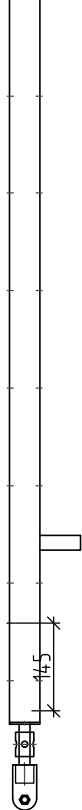

*Support tube with spindle*

Part No.	Description	Number
557234	Support tube	1
557237	Spindle mount	1
557238	Spindle	1
360366	Bolt M20x100	1
380030	Washer A21	1
373016	Safety nut M20	1
912519	Cotter pin 6x26	2

*Wheel flange with rear fixing*



Part No.	Description	Number
557241	Wheel flange plate	4
557244	Wheel flange roller	4
360370	Bolt M20X120	2
380030	Washer A21	2
373016	Safety nut M20	2
389004	Shaft safety ring	4
381024	Washer A15	4
557232	Pin	1
557233	Back fixing	1

*Attaching to NOE top formwork*



Part No.	Description	Number
557242	Fastening bow	1
135019	Connection bolt	1
680580	Sprint nut	1
319338	Hammerhead bolt	2

2 fastening sets are required for each support tube.

*Push-pull brace with fastening*

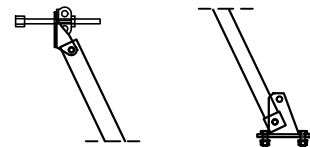

*Front safety fastening*



Part No.	Description	Number
557239	Front safety fastening	1
680580	Sprint nut	2
360374	Bolt M20x140	1
380030	Washer A21	1
373016	Safety nut M20	1

Part No.	Description	Number
697024	Push-pull brace	1
135019	Connection bolt	1
680580	Sprint nut	1
362344	M16x40 bolt	2
370024	Nut M16	2
380026	Washer A17	2



**THE FORMWORK**



**NOE-Schaltechnik  
Georg Meyer-Keller GmbH + Co. KG**

Kuntzestr. 72, 73079 Suessen, Germany  
T + 49 7162 13-1  
F + 49 7162 13-288  
info@noe.de  
www.noe.de  
www.noeplast.com

**Austria**

NOE Schaltechnik  
www.noe-schaltechnik.at  
noe@noe-schaltechnik.at

**Belgium**

NOE Bekistingtechniek N.V.  
www.noe.be  
info@noe.be

**France**

NOE France  
www.noefrance.fr  
info@noefrance.fr

**Netherlands**

NOE Bekistingtechniek b.v.  
www.noe.nl  
info@noe.nl

**Poland**

NOE PL Sp Zo.o.  
www.noe.pl  
noe@noe.pl

**Switzerland**

NOE Schaltechnik  
www.noe.ch  
info@noe.ch